

HESSAPP

DVH SERIES

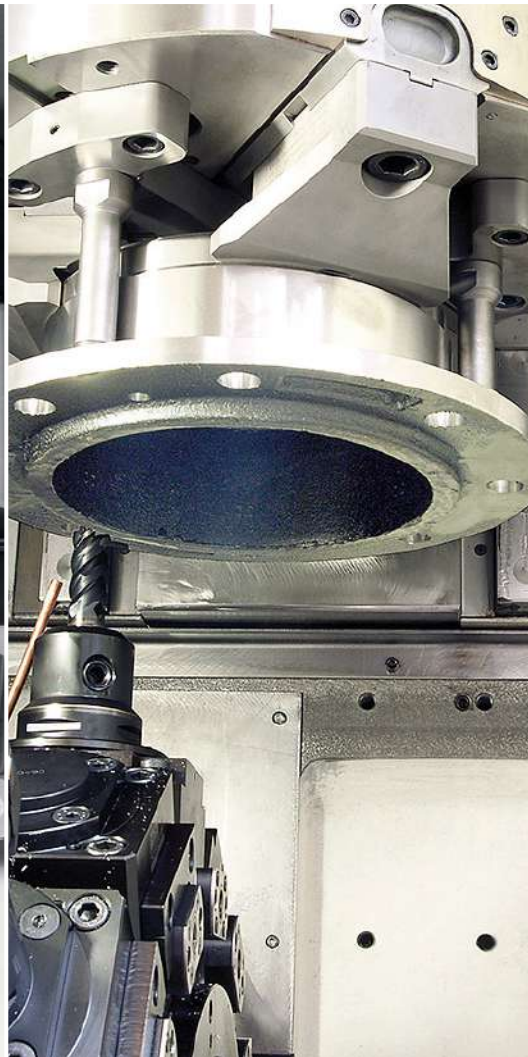

Pick-Up Vertical Turning Machines



DVH Series – The Latest in Turning

Pick-up Turning Machines

A guarantee of maximum productivity and quality in modern production. More than 20 years of experience in the development and production of pick-up style vertical turning machines combined with continuous further development help you to master the process requirements of today.

The consistent focus on technological solutions has given rise to an enormous pool of knowledge and experience – from which you, too can benefit.

The series is divided into three basic models

► DVH – the classic single spindle pick-up model

An ideal combination of price and performance coupled with optimum manufacturing solutions

► DVH DUO – the highly productive dual spindle model

Dual spindle pick-up vertical turning machine for use in highly productive manufacturing

► DVH 4X – the highly productive single spindle model

Self-loading 4-axis vertical turning machine for the optimum accomplishment of machining operations, offering high potential savings of up to 45 % compared with conventional 2-axis machining



Technologies

- ▶ Turning
- ▶ Drilling
- ▶ Milling
- ▶ Grinding
- ▶ Hard turning
- ▶ Gear machining

Industries

- ▶ General mechanical engineering
- ▶ Aerospace
- ▶ Automotive
- ▶ Commercial vehicles
- ▶ Construction machinery
- ▶ Fittings

Extract from the workpiece range



Advantages

The Pick-up Principle

- ▶ Integrated automatic loading/unloading
- ▶ Low cost per piece through high productivity
- ▶ Multiple machine operation as the machine is decoupled from the operator

Components and Options

- ▶ Reliable, tried-and-tested components
- ▶ Numerous options for your individual DVH
- ▶ Highly versatile
- ▶ Rapid installation and production start-up

Expansions to the Basic Version

- ▶ X- and Y-axes for drilling operations
- ▶ Additional 4-axis cross slide (improves efficiency by up to 45 %)

Excellent Ergonomics

- ▶ Easily accessible, generous work area
- ▶ Ideal setup conditions, ensuring extremely short unproductive downtimes
- ▶ Large window for monitoring the manufacturing process

Flexible Handling Systems

- ▶ Low-cost standard handling systems
- ▶ Flexible handling solutions adapted to the production flow
- ▶ Extremely diverse range of options (robot loading, connection to gantry loaders, batch hoppers, etc.)

Functional Design – Transfer Technology

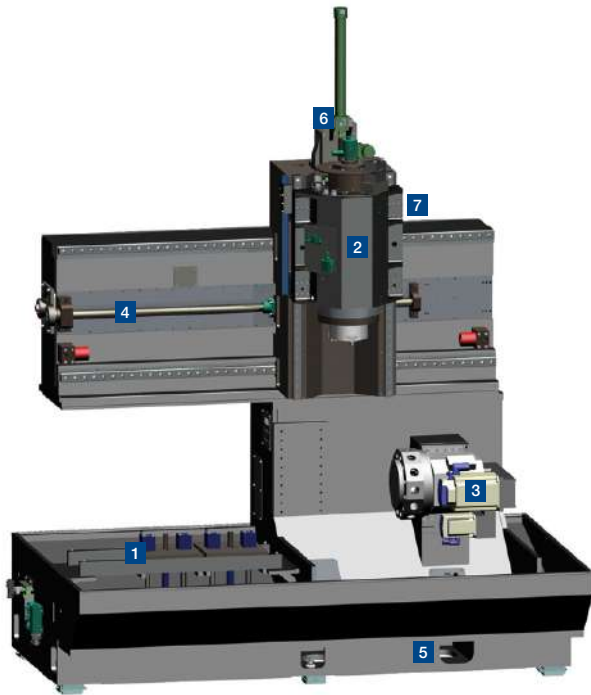

DVH Standard configuration

- 1 Automatic workpiece loading and unloading with hydraulic lift unit and run-over protection
- 2 Travelling motor spindle
- 3 Turret
- 4 Ball screw drive
- 5 Tray-type enclosure
- 6 Hydraulic counter balancing
- 7 Linear measuring system in all axes

DVH Pick-up vertical turning machine

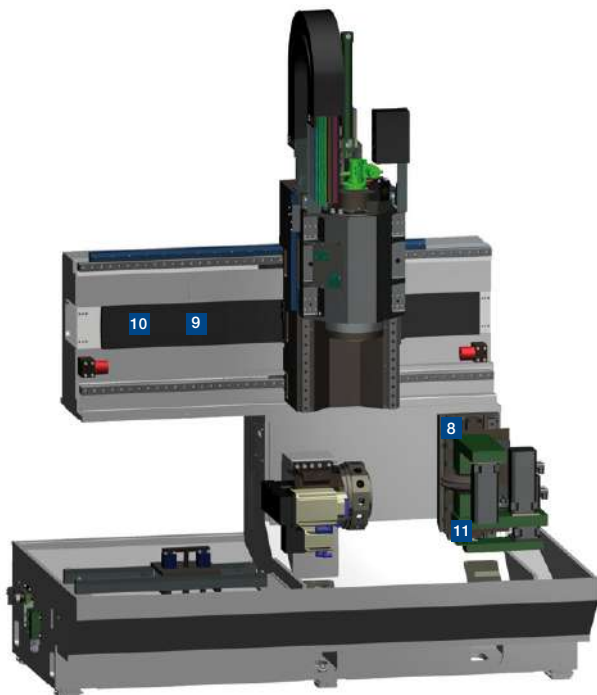

DVH Auxiliary components

- 8 Y-axis
- 9 Linear drive
- 10 Linear guides with integrated measuring systems
- 11 Technology modules for grinding, NC-slide, drilling, milling

DVH with auxiliary units from the modular machine kit

Modular System



Motor spindle

- ▶ max. 42 kW (40 % duty)
- ▶ max. 5000 rpm



Motor spindle

- ▶ max. 71 kW (40 % duty)
- ▶ max. 4000 rpm



Motor spindle

- ▶ max. 80 kW (40 % duty)
- ▶ max. 4000 rpm



Drilling/milling unit

- ▶ 100 Nm / 3000 rpm
- ▶ B-axis*



Multiple drill head

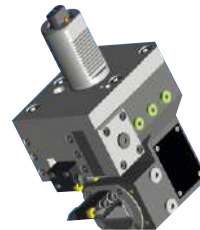

**Tool holder with
NC lift-off slide**



Crown turret



Turret with live tools

- ▶ 100 Nm / 4000 rpm
- ▶ 250 mm tool length



Multifunction plate



NC lift-off slide

- ▶ Stroke max. 40 mm
- ▶ For holding static tools
- ▶ Workpieces up to Ø 500 mm



Workpiece gauge

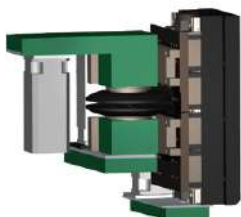

Grinding/milling unit

- ▶ Working stroke max. 80 mm
- ▶ Speed max. 3000 rpm



**Oval conveyor belt drag
conveyor**



**Inverted-tooth chain
driven conveyor**



Flat chain driven conveyor

Standard Options

Crown Turret



- ▶ For complex drilling tasks
- ▶ Sturdy design
- ▶ Short indexing times
- ▶ 6 tool holders
- ▶ Use of driven tools

Technical Data – Crown Turret

Speed range max	rpm	2500
Power max. (at 40% duty)	kW	68
Torque (at 40% duty)	Nm	260

Drilling/Milling Unit



- ▶ For advanced drilling and milling operations
- ▶ Additional tool positions

Technical Data – Drilling/Milling Unit

Rating class		1	2
Speed max.	rpm	4500	3000
Torque	Nm	40	100
Power	kW	20	23

Drilling Turret



- ▶ Rigid design
- ▶ Short indexing times
- ▶ 12 tool stations
- ▶ Use of driven tools

Technical Data – Drilling Turret

Speed range max.	rpm	3000
Power max. (at 25% duty)	kW	24,8
Torque (at 25% duty)	Nm	79

Swiveling Turret (B-axis)



- ▶ Swiveling range 0 – 45°
- ▶ Programmable angle adjustment
- ▶ 12 tool stations
- ▶ No driven angle tools required

Multiple drill head



- ▶ Reduced cycle times
- ▶ Available as separate units
- ▶ Available as add-on for turrets

Highly Dynamic Motor Spindles



- ▶ High speeds
- ▶ High motor power
- ▶ Liquid-cooled, ensuring high thermal stability and low noise
- ▶ High-precision positioning through integrated C-axis
- ▶ Integrated clamping stroke monitoring / maintenance-free

CNC controls

SIEMENS
FANUC

- ▶ Siemens
- ▶ Fanuc

Machine Units and Options for Your Individual Machine

Driven Tools

Turning, drilling, milling and tapping in a single chucking offers the best machining quality. No setup is needed between operations and the number of fixtures required is reduced.

Workpiece Gauge

When gauging takes place in the machine, the motor spindle and the workpiece contact a measuring probe during a measuring cycle. Gauging outside the machine has the advantage of taking place during the machining time

A Choice of Two Systems

- ▶ Gauges with workpiece-specific parts such as snap gauges and measuring heads
- ▶ CNC gauging machine with freely programmable measuring cycles

Tool Gauge

By using our own special designed software, the operator is able to gauge new tools with maximum precision and automatically correct them in the tool magazine

Tool Breakage and Wear Monitoring

To increase the uptime of the DVH, the machines can be equipped with a tool edge and collision monitoring system. In the event of tool breakage, wear or collision, an emergency shutdown module brings the feed axes to an immediate halt.

Grinding

Grinding process with integrated automatic dressing and special grinding cycles. Grinding wheels of corundum, CBN and other materials are used. Special grinding devices are available for producing the parallel keys of gears.



Workpiece gauging can be done in a clean environment outside the work area

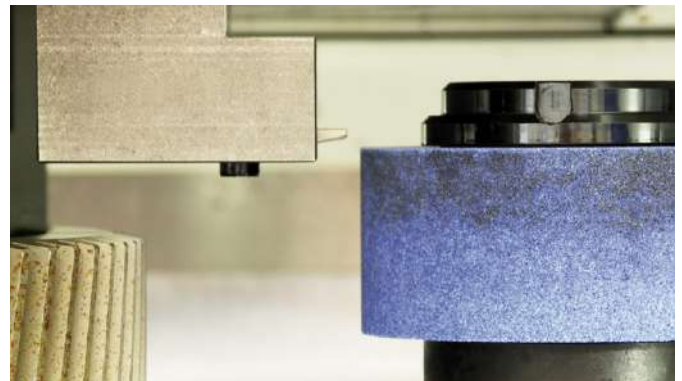

Automatic dressing of a grinding wheel

DVH 200 / DVH 300



DVH 200 / 300

- ▶ For workpieces with a swing diameter of up to 200 / 300 mm
- ▶ Despite the compact design, all machine units – such as the spindle, chuck and tool turret – can be easily reached for setup work
- ▶ The multifunction plate offers space for various machining modules, e.g. drilling, milling and grinding, as a further option to the tool turret
- ▶ Electric turret drive for minimal thermal effects
- ▶ Machine bed available as mineral casting

Performance and flexibility features:

- ▶ Powerful motor spindle
- ▶ High axis speeds
- ▶ Wide range of configuration options from existing modular system
- ▶ Y-axis for complete machining
- ▶ Various chip conveyors, coolant systems (high pressure) and filtering methods
- ▶ Large selection of different tools and tool carrier systems
- ▶ Customized workpiece feed and removal



Ergonomic work area

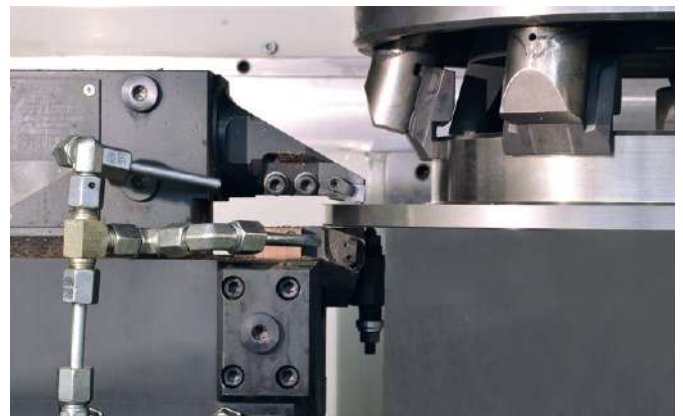

Lift-off slide in turret

Technical Data

		DVH 200	DVH 300
Work area			
Turning diameter max.	mm	200	320
Swing diameter max.	mm	250	280
Workpiece height with chuck	mm	315	300

DVH 400 / DVH 500



DVH 400 / 500

- ▶ For workpieces with a swing diameter of up to 510 mm
- ▶ Superior cutting performance and outstanding ergonomics coupled with ideal use of the installation space
- ▶ Extremely diverse range of options for optimum process organization
- ▶ Integration of additional tool carriers, grinding spindles, milling spindles and multiple drill heads

Performance and flexibility features:

- ▶ Powerful motor spindles achieving up to 80 kW set standards in this class
- ▶ High axis speeds
- ▶ Wide range of configuration options from proven modular system
- ▶ Y-axis for complete machining
- ▶ Various chip conveyors, coolant systems (high pressure) and filtering methods
- ▶ Large selection of different tools and tool carrier systems
- ▶ Customized workpiece feed and removal
- ▶ Modular tooling systems suitable for high pressure cooling up to 80 bar
- ▶ Tooling for NC lift-off operations

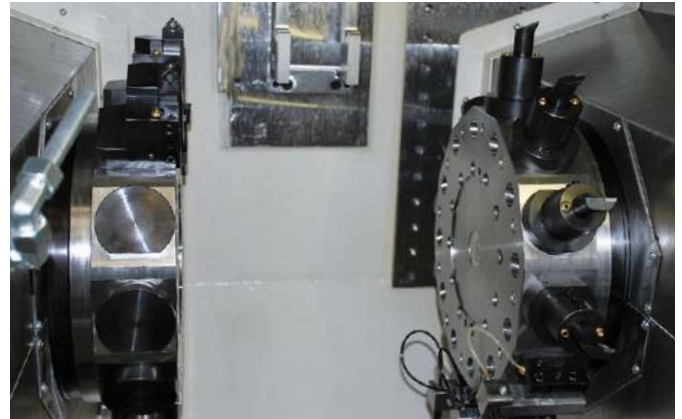

Dual turret for max. 24 tools available



Turn-grinding

The surfaces of the brake are simultaneously ground on both sides with a rotating workpiece and a rotating tool in a single machining operation.



Turn-milling

Twin milling unit with milling spindles in opposing directions, for machining brake surfaces on the DVH 500.

Technical Data

	DVH 400	DVH 500
Work area		
Turning diameter max.	mm 450	500
Swing diameter max.	mm 510	510
Workpiece height with chuck	mm 450	450

DVH 630 / DVH 750



Thermo-symmetrical spindle construction employed consistently in all machines for maximum precision

DVH 630 / 750

- ▶ For workpieces with a swing diameter of up to 630/750/900 mm
- ▶ Superior cutting performance and outstanding ergonomics coupled with ideal use of the installation space
- ▶ Very diverse range of options for optimum process organization
- ▶ Integration of additional tool carriers, grinding spindles, milling spindles and multiple drill heads

Performance and flexibility features:

- ▶ Powerful motor spindles for use in heavy cutting with a torque of up to 3000 Nm
- ▶ Workpiece weight of up to 300 kg
- ▶ Rigid machine construction for holding workpiece and chuck weights
- ▶ Y-axis for complete machining
- ▶ Broad range of configuration options from existing modular system
- ▶ Variable chip conveyors, coolant systems (high pressure) and filtering methods
- ▶ Large selection of different tools and tool carrier systems
- ▶ Customization of workpiece feed and removal
- ▶ Modular tooling systems suitable for high pressure cooling up to 80 bar

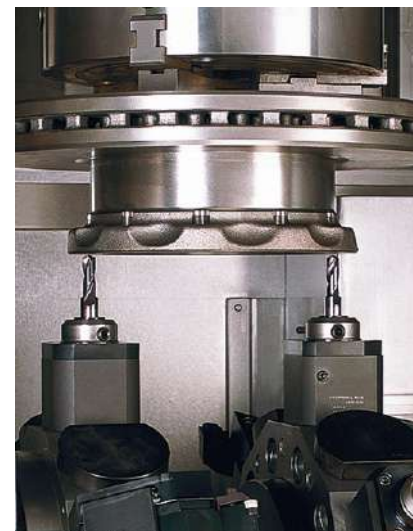

Two drilling turrets and additional Y-axis



Hard turning / grinding option

Technical Data

		DVH 630	DVH 750
Work area			
Turning diameter max.	mm	570	630
Swing diameter max.	mm	630	750
Workpiece height with chuck	mm	450	500

Material Handling Systems – Flexible, Trouble-free, Adapted to the Job

Handling Systems

The Hessapp portfolio includes low-cost standard solutions or, as an alternative, customized versions adapted to the task at hand.

Ultra-flexible Standard Handling Systems

The oval conveyor system comes equipped with workpiece frames adapted to the workpiece diameter, for default positioning in the frame. Setup is easy with no mechanical work, as the diameter is simply entered in the machine control system. If workpiece positioning is required, the user can easily produce a guide himself and insert it in the existing workpiece frame.

Customized Solution

Special customized solutions are designed based on the user's requirements in terms of components, space conditions and linking with other machines. Complete automated handling systems with logistics software are also possible. Connection to palletizers for highly productive manufacturing systems is available for medium to large-scale batch production.

Closed-loop Recirculating Pallet Conveyor for Workpiece Frames

The workpieces are moved by easily replaceable workpiece frames

DVH 200: Three Frame Sizes

ø 50–80 mm	ø 80–130 mm	ø 130–200 mm
32 frames	22 frames	16 frames

DVH 400 / 500: Three Frame Sizes

ø 150–250 mm	ø 250–350 mm	ø 350–450 mm
20 frames	15 frames	12 frames



Line of pallets



Roller/chain combination



Chain driven conveyor with pallets



Chain driven conveyor



Pallet (close-up)

Technical Data

Machine type		DVH 200		DVH 300		DVH 400
Working area						
Turning diameter max.	mm	200		320		450
Swing diameter max.	mm	250		280		510
Part height with chuck	mm	315		300		450
Motor spindle						
		RC* 1		RC* 2		
Front bearing diameter	mm	100		100		150
Spindle nose	DIN	55 026		55 026		55 026
Spindle taper	size	A6		A6		A11
Speed max.	rpm	6500	5500	5500		4000
Motor power at 40% duty	kW	35	34	36		80
Torque at 40% duty	Nm	210	360	360		795
Feed rate / rapid traverse						
Rapid traverse Z-axis	m/min	30		30		30
Rapid traverse X-axis	m/min	60		60		75 / 90
Tool turret						
Tool positions	number	12		12		12
Cylinder shank ø mm	DIN 69880	40		40		40
Tool length max.	mm	180		170		250
Machine foot print						
Dimensions L x W x H	m	2.5 x 2.4 x 2.9		2.5 x 2.4 x 2.9		3.2 x 2.7 x 3.3
Weight	kg	6500		6500		9500

* RC = Rating class

Machine type		DVH 500	DVH 630	DVH 750
Working area				
Turning diameter max.	mm	500	570	630
Swing diameter max.	mm	510	630	750
Part height with chuck	mm	450	450	500
Motor spindle				
Front bearing diameter	mm	150	180	220
Spindle nose	DIN	55 026	55 026	55 026
Spindle taper	size	A11	A11	A15
Speed max.	rpm	4000	2800 / 800	2000 / 800
Motor power at 40% duty	kW	80	80 / 68	55 / 68
Torque at 40% duty	Nm	795	1150 / 2950	1780 / 2950
Feed rate / rapid traverse				
Rapid traverse Z-axis	m/min	30	30	20
Rapid traverse X-axis	m/min	75 / 90	45 / 60	32
Tool turret				
Tool positions	number	12	12	8
Cylinder shank ø mm	DIN 69880	50	50	60
Tool length max.	mm	260	270	300
Machine foot print				
Dimensions L x W x H	m	3.4 x 2.7 x 3.3	2.5 x 2.3 x 3.2	4.8 x 2.6 x 4.1
Weight	kg	13 500	15 000	20 000

Subject to change without notice

OEM Service for our Brands and Legacy Brands

VDF BOEHRINGER **NAG** **LEADWELL**



Service Center Goeppingen
Goeppinger Strasse 50, DE-73033 Goeppingen
Tel.: +49 7161 201-0

JOBS **RAMBAUDI** **SACHMAN**



Jobs GmbH
Aindlinger Strasse 3, 86167 DE-Augsburg
Tel.: +49 821 5976 630

HESSAPP



Service Center Taunusstein
Aarstrasse 157, DE-65232 Taunusstein
Tel.: +49 6128 243 260

MODUL



Service Center Chemnitz
Marienberger Strasse 17, DE-09125 Chemnitz
Tel.: +49 371 576 386

Honsberg



Service Center North/West
Stefansbecke 30, DE-45549 Sprockhoevel
Tel.: +49 2339 9278 0

Pfiffner



K.R. Pfiffner AG, Utzenstorf
Sonnmattdstrasse 28, CH-3427 Utzenstorf
Tel.: +41 32 666 35 35

WITZIG & FRANK



Service Center Offenburg
Am Holderstock 2, DE-77652 Offenburg
Tel.: +49 781 289 1121



FFG 24/7 Service and Support:
www.ffg-werke.com/24x7

Service and support

- ▶ Commissioning
- ▶ Maintenance and inspections
- ▶ Repair service
- ▶ Spindle service
- ▶ Overhaul and retrofit
- ▶ Used machines
- ▶ Service contracts
- ▶ Machine relocation



Process and production optimization

- ▶ Process optimization
- ▶ Programming
- ▶ Software: machine data acquisition, diagnosis, condition monitoring, energy management, virtual machine

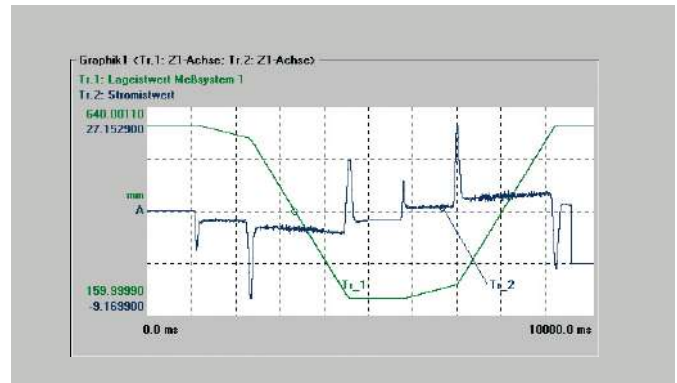
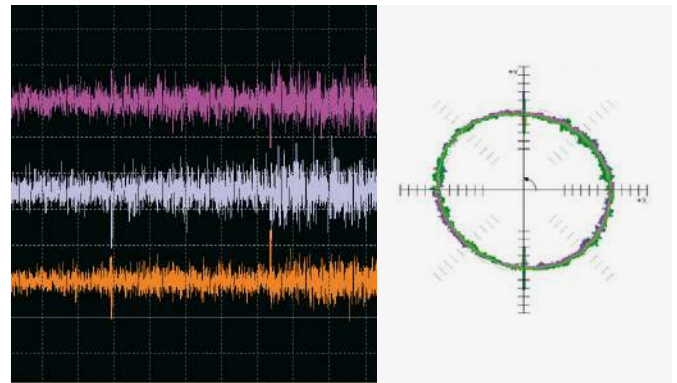

Machine condition monitoring "Finger print" via vibration analysis, ballbar test and trace measurement.

Spare parts

- ▶ 24/7 delivery
- ▶ Central warehouse
- ▶ Individual service concepts



Training

- ▶ Operator training
- ▶ Maintenance training (mechanical, electrical)
- ▶ Programming training



VDF BOEHRINGER

HESSAPP



meccanodora



MORARA



TACCHELLA

WITZIG & FRANK

About FFG Europe & Americas

The FFG entities in Europe and the Americas unite major players from the German, Italian, Swiss and American machine tool industry with a broad range of milling, turning, grinding, and gear manufacturing technology, and the knowhow of the renowned machine tool brands VDF Boehringer, Hessapp, IMAS, Jobs, MAG, Meccanodora, Modul, Morara, Pfiffner, Rambaudi, Sachman, Sigma, SMS, Tacchella and Witzig & Frank. Since 1798, these brands have substantially contributed to the progress in industrial manufacturing and are well known as reliable and innovative equipment and systems solutions suppliers for the automotive and truck, aerospace, machine building, general machining, railway industry, energy and heavy engineering industries. While being an independent group, these entities benefit from the strengths and opportunities of the global Fair Friend Group. They stand for premium technology within FFG.

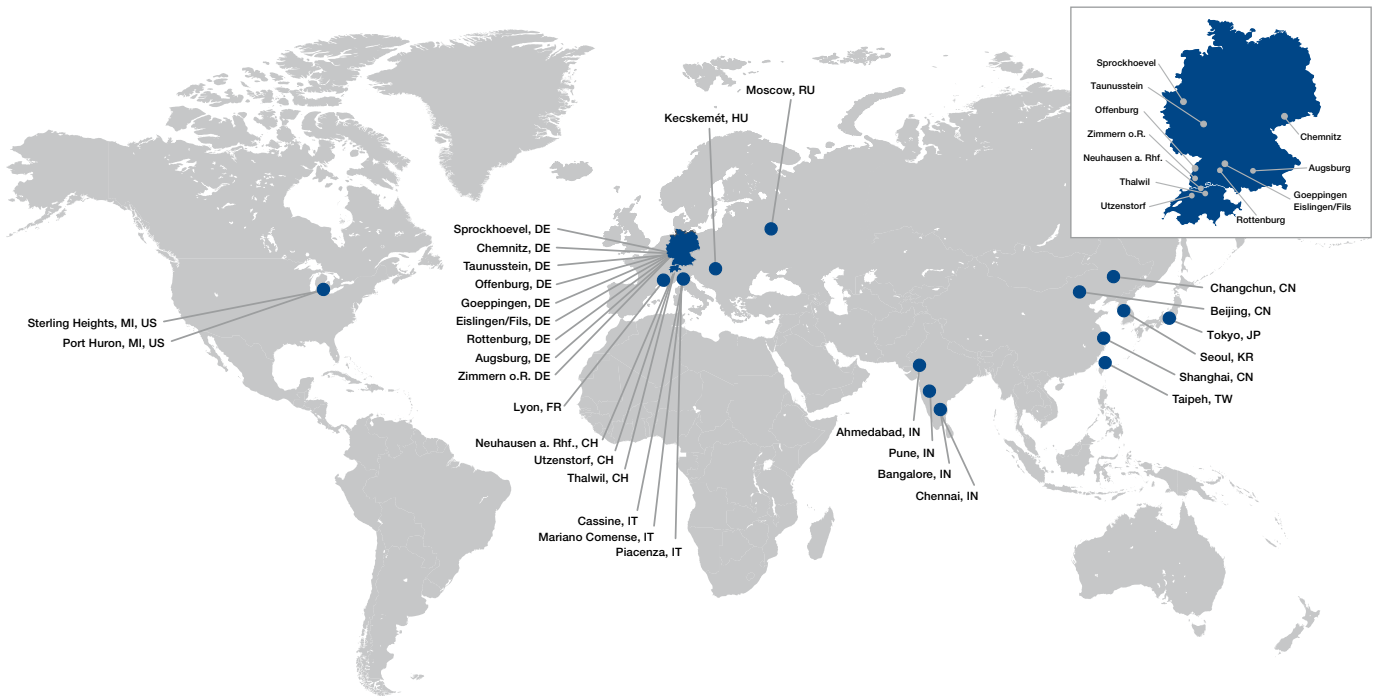

FFG Europe & Americas

FFG Werke GmbH
Aarstrasse 157
DE-65232 Taunusstein-Hahn
Tel. +49 61 28 243-0
Fax +49 61 28 243-111

FFG Werke GmbH

info@ffg-werke.com

www.ffg-werke.com



FFG 24/7 Service and Support: www.ffg-werke.com/24x7



Made in Germany since 1789