

**The Ultimate in Performance**

## **LC Series**



**LCH-500/LCV-760  
Travel Column APC Machining Center**

**LEADWELL**  
LEADWELL CNC MACHINES MFG., CORP.

**LEADWELL CNC MACHINES MFG., CORP.**



No. 23 Gong 33th Road, Taichung Industrial Park  
Taichung 407, Taiwan  
T: 886 - 4 - 23591880  
F: 886 - 4 - 23592555, 886 - 4 - 23593875  
E: sales@leadwell.com.tw

[www.leadwell.com.tw](http://www.leadwell.com.tw)

\* All performance are based on 220V/3PH/60HZ. Specifications are subject to change without notice.



## STRUCTURE

### OPTIMUM STRUCTURE

- LEADWELL uses only top quality well-ribbed castings.
- The specially designed machine structure allows easy conversion between vertical and horizontal machining functions. This upgrades the economic efficiency while lowering the investment costs.
- Finite Element Analysis (FEA) is used on each new casting to determine the size and location of all internal ribs ensuring high torsional stiffness and minimum vibration.
- The rigid T-shaped, single-cast base construction provides excellent rigidity and avoids overhang of the stationary table.
- Special design of three linear ways on the base eliminates column tilting problems. Also, the compact traveling column design features relatively less floor space and excellent access to the machine table.
- The structural parts, such as the base, column, saddle, headstock and tables are ruggedly constructed for superior stability and machining accuracy.

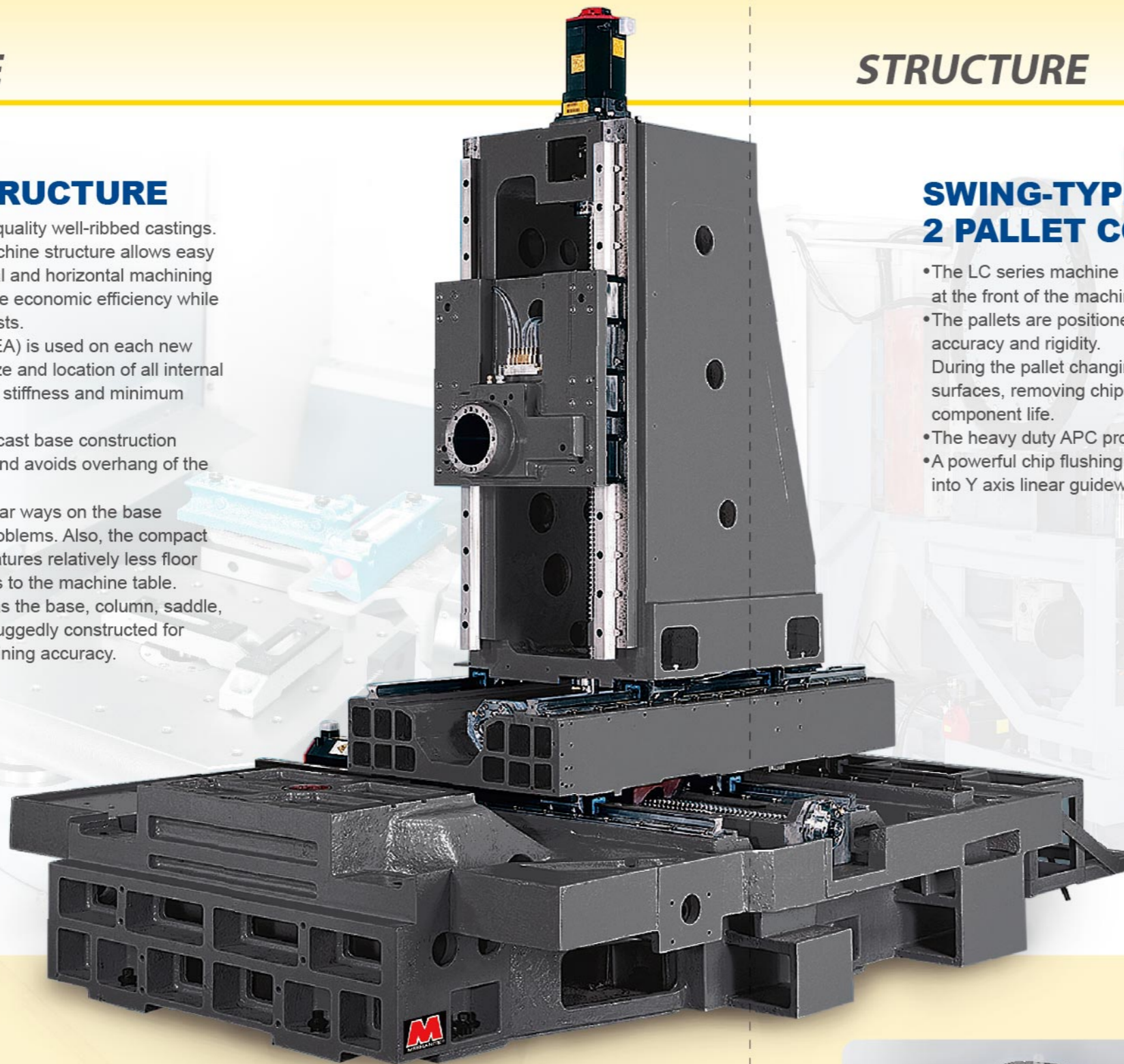

### PRECISION SPINDLE MINIMUM VIBRATION IN 3 $\mu$

The spindle is driven by a powerful motor featuring high torque output. Unique spindle stability is controlled in 3 $\mu$  for any speed. The four gripper tool clamping design assures extremely stable clamping force.

10,000 or 12,000 R.P.M. SPINDLE SPEED

The spindle provides a maximum speed of 10,000 R.P.M. as standard. Upon request, a belt transmitted 12,000 R.P.M. spindle is available as optional.



## STRUCTURE

### SWING-TYPE APC & 2 PALLET CONFIGURATION

- The LC series machine has a standard 2 pallets, swing-type changer system, the loading position at the front of the machine allows easy loading and unloading of workpieces.
- The pallets are positioned and clamped to the table with four precision taper cones to ensure accuracy and rigidity. During the pallet changing cycle, compressed air is blown through the cones to clean the clamping surfaces, removing chips and coolant. This air assures pallet location accuracy and long component life.
- The heavy duty APC provides 500 kg loading capacity on each pallet.
- A powerful chip flushing channel is equipped on both sides of Y axis to prevent chips from entering into Y axis linear guideways and transmission mechanism.

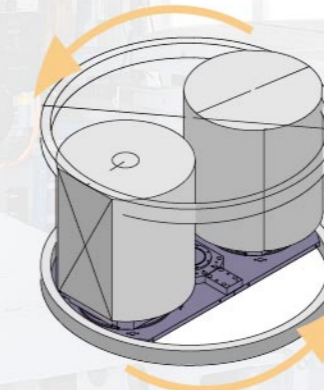

LCH-500

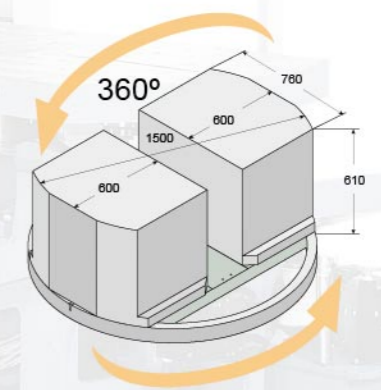

LCV-760

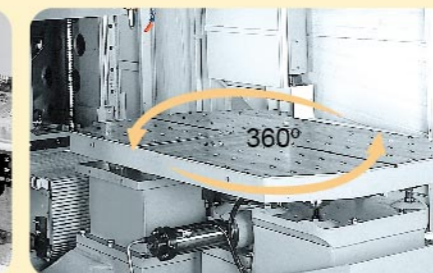

### ACCURATE TABLE POSITIONING

The table is positioned and clamped by extra-large male and female cones thereby assuring high accuracy jointing and excellent rigidity. Additionally, an air leakage sensor is provided to ensure secure clamping. The swing table is fully interchangeable with the pallet.



## FEATURES

### CHIP REMOVAL IN CUTTING AREA

- The chips can drop directly into the cutting area thereby preventing machine heat growth due to chip deposition and erroneous motion.
- A powerful chip flushing channel is equipped on both sides of Y axis to prevent chips from entering into Y axis linear guideways and transmission mechanism.

### INCLINED METAL RAMP

- The CE certified, fully enclosed splash guard, combined with the inclined metal ramp, exhaust chips out of the machine thoroughly and efficiently. This prevents machine parts from being damaged.
- The chip curtain is equipped at both sides of X axis and synchronized telescopic guards at bottom.

### CHIP AUGERS

- Leadwells' simple and efficient design uses chip augers on the base of the machine and provides high volume coolant to wash the chips from the working area. The auger transfers chips into the disposal container, which eliminates the need for an operator to manually remove chips.
- A safety foot step is provided with the machine for added safety for the operator.

## FEATURES

LCH-500

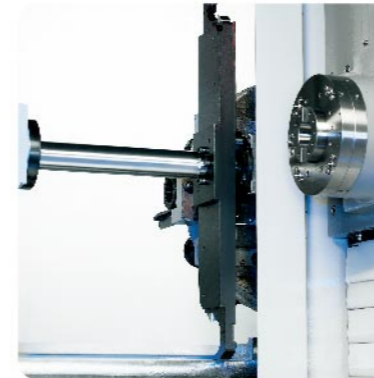

LCV-760

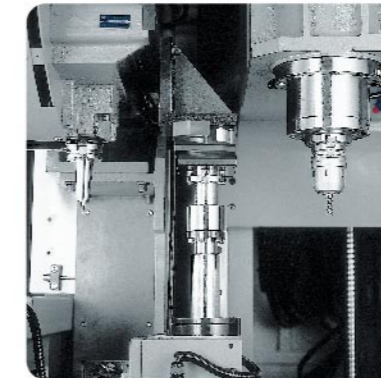

### SIDE MOUNTED ATC

- The compact ATC is mounted at the side of the machine base for reducing packing volume and saving freight.

LCH-500

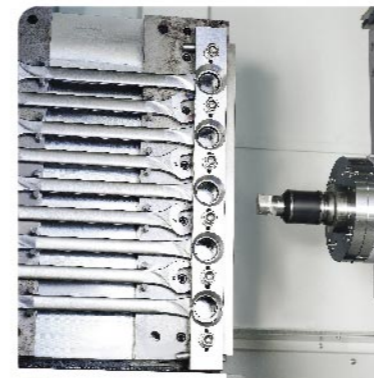

LCV-760



### CHIP GUARD ON MAGAZINE

- The auto door for the tool magazine prevents chips from damaging the magazine.

### CHAIN TYPE MAGAZINE(standard)

- It is equipped with 40 tool chain type magazine combined with an arm type tool change system.
- Fast tool change can be accomplished in 3 seconds (tool to tool) and 6 seconds (chip to chip).

LCH-500

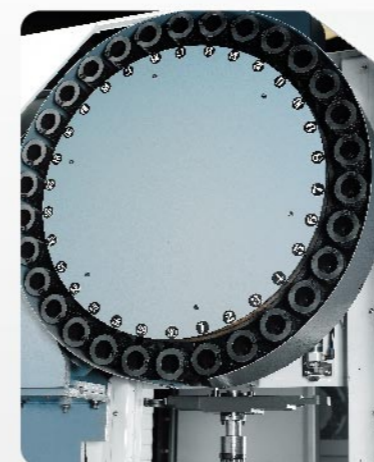
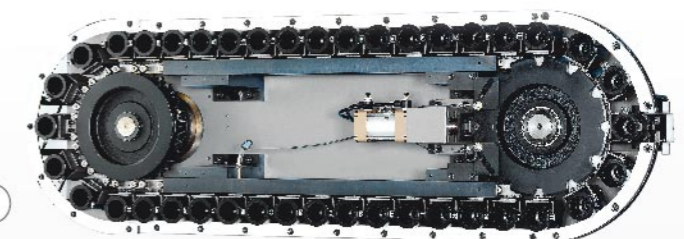

### ATC with 30 tools (standard)

- Tool change time is 3 seconds (tool to tool) and 10 seconds (chip to chip).
- Bi-directional, random tool selection for efficient tool changing.

LCV-760



## OPTIONAL

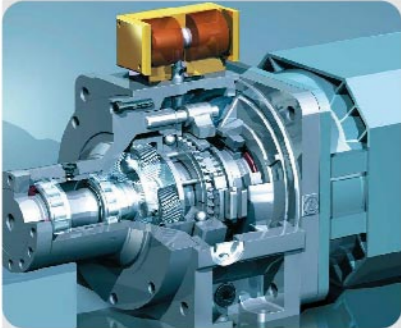

### HIGH TORQUE SPINDLE

- The cutting torque is maximized by combining the German ZF-2-speed gear box with the oil cooled main spindle.
- The gearbox has its own separate lubrication system.



### COOLANT THROUGH SPINDLE (CTS)

- It's includes an auxiliary high-pressure pump, which supplies high pressure coolant to the cutting edge. CTS improves tool life, allows both deep hole drilling and blind pocket milling. It also allows for higher speeds, which reduces the cycle time.

### TOOL PROBE

- It uses marco programming to automatically define and update tool offsets. This option will easy setup and check for broken tools.



### OIL SKIMMER

- Designed for collecting the oil dust in the coolant tank for reclamation and meeting environmental protection requirements.

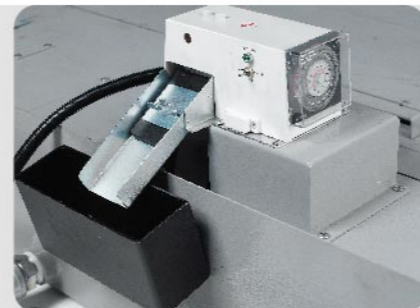

### SPINDLE PROBE

- It uses a spindle probe and custom macro. This option simplifies workpieces setup by automatically storing work offsets to the machine offset register. This spindle probe, in conjunction with macro programs, is capable of performing rapid first part inspection, in process reporting, and unmanned machining operations.



## EXCELLENT FOR DIVERSIFIED INDUSTRIES

- Precision (profiled) parts machining
- General mold machining
- Automotive and motorcycle part machining
- 3C industries
- Aerospace parts machining
- Semi-conductor industry
- FMC & FMS unmanned production lines

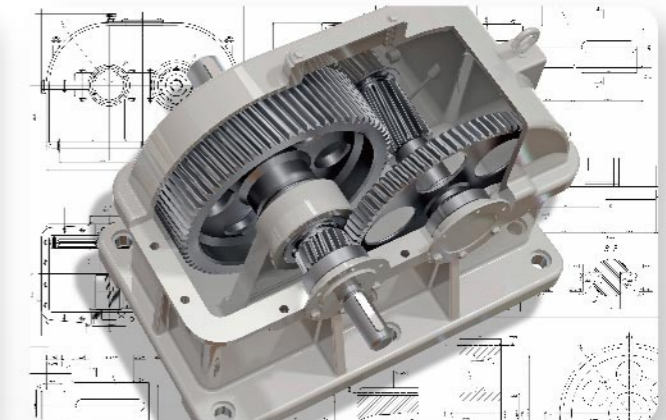
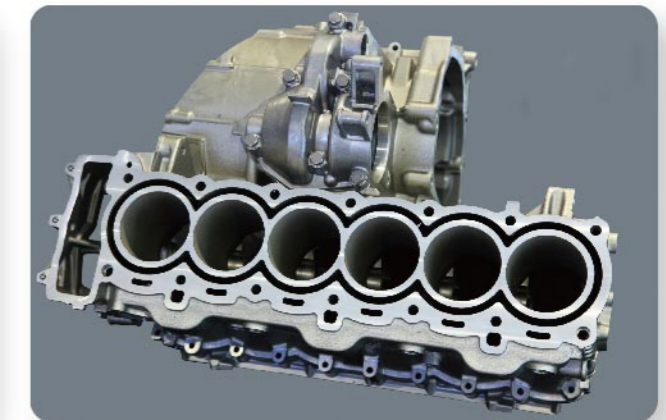
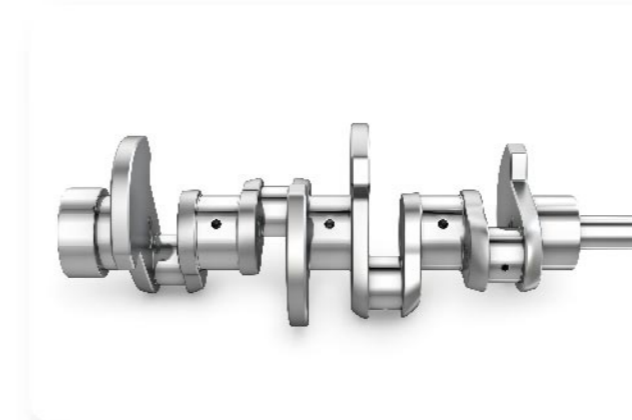



# LEADWELL SMART PROCESSOR

## More than a machine

Leadwell is never simply about building a machine and to launch onto the market. Our years of experience, we learn that the right programs must be developed to ensure the competitiveness of the users.

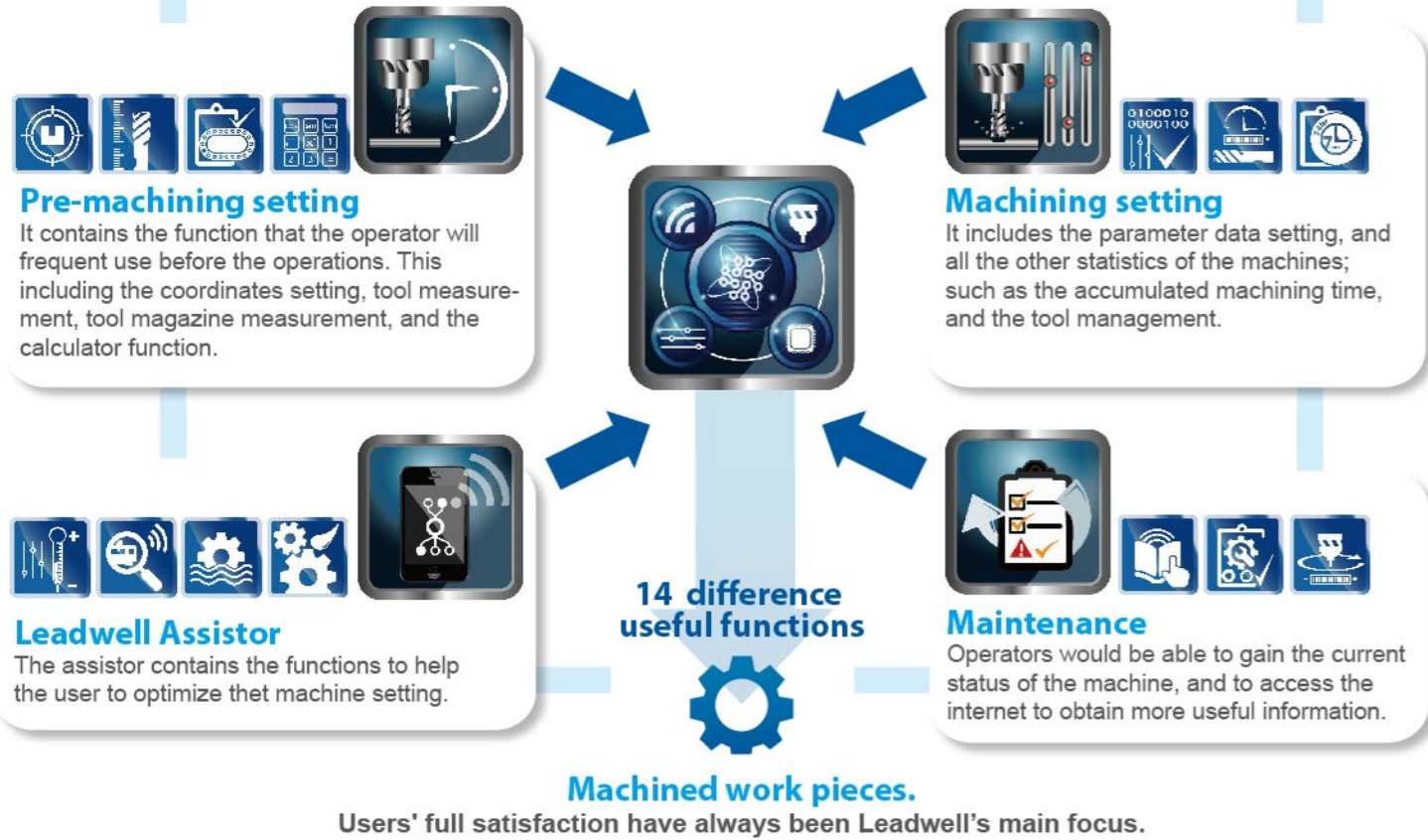

# OUTLINE & INTERNAL DIMENSION

## LCH-500

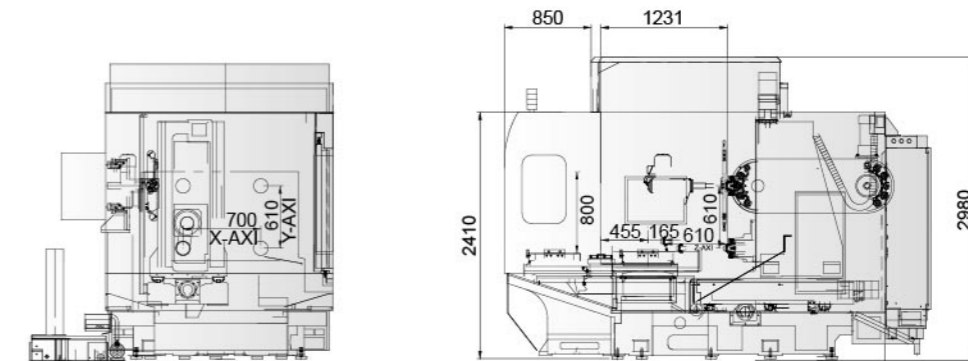
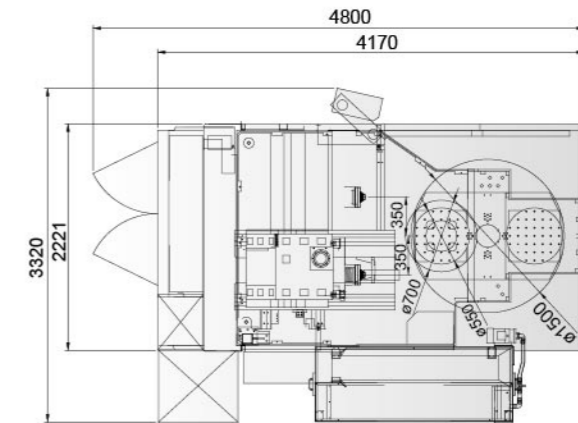

## LCV-760

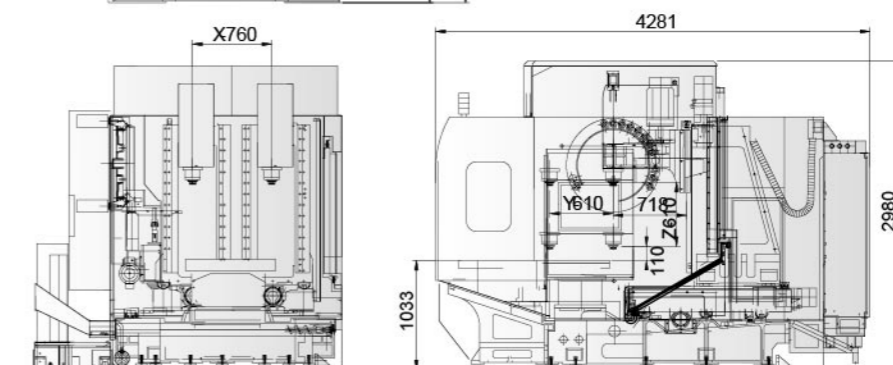
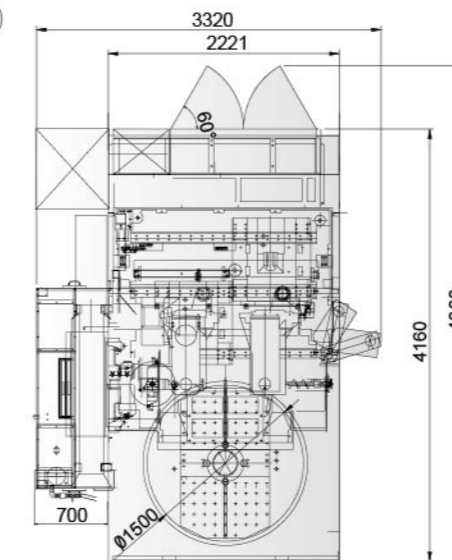

## PERFORMANCE

### MH-630

#### FACE MILL

Removal Rate	<b>400cc/min.</b>
Tool	Ø125mm
Spindle Speed	1500rpm
Feed Rate	1000mm/min
Width of Cut	80mm
Depth of Cut	5mm

#### TAP

Tapping	<b>M24</b>
Spindle Speed	250rpm
Feed Rate	750mm/min.

#### U-DRILL

Drilling	<b>Ø60mm</b>
Tool	Ø60mm
Spindle Speed	1500rpm
Feed Rate	100mm/min.
Depth of Cut	55mm

#### RIGID TAP

Tapping	<b>M24</b>
Spindle Speed	1000rpm
Feed Rate	3000mm/min.



# SPINDLE POWER CURVE

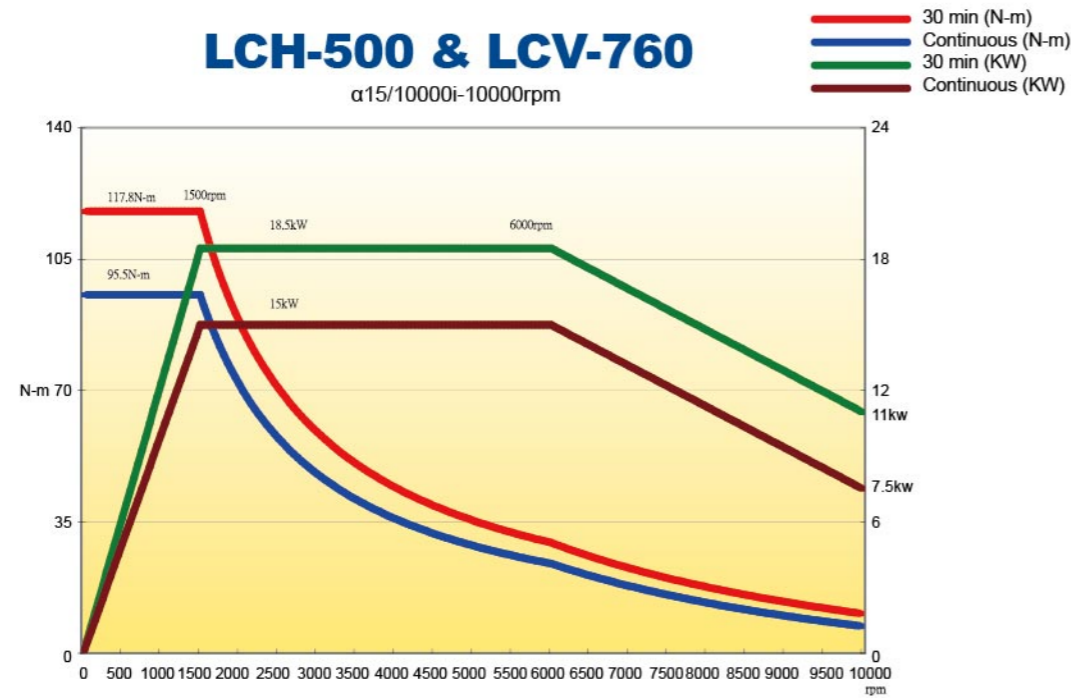

# TOOL SHANK SPECIFICATIONS

**BT 40**

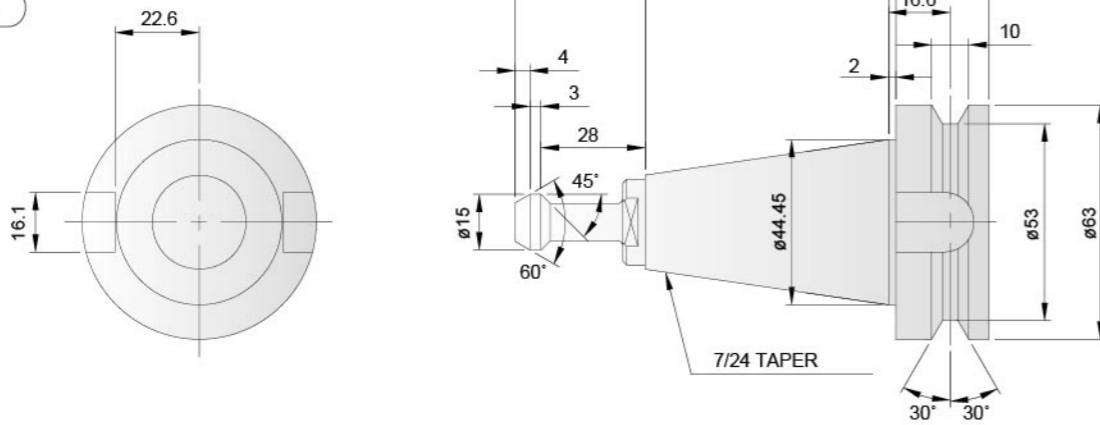

**CAT 40**

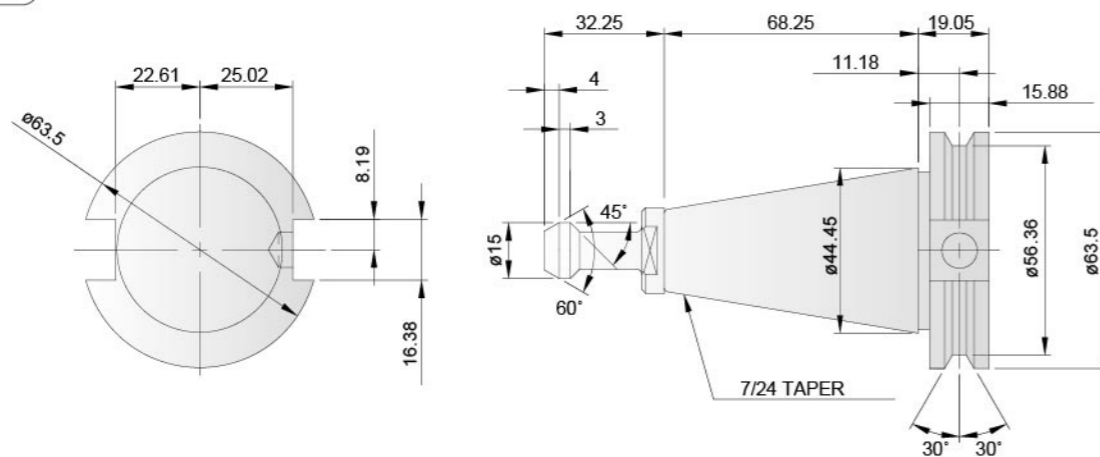

# MACHINE SPECIFICATIONS

ITEM	MODEL	LCH-500	LCV-760
<b>CAPACITY</b>			
X axis travel	mm(in)	700 (27.5)	760 (29.9)
Y axis travel	mm(in)	610 (24)	610 (24)
Z axis travel	mm(in)	610 (24)	610 (24)
Distance from table top to spindle center	mm(in)	50-660 (1.96-25.9)	110-720 (4.3-28.3)
Distance from table center to spindle end	mm(in)	175-785 (6.86-30.9)	718 (28.2)
<b>TABLE</b>			
Table size	mm(in)	500x500 (19.6X19.6)	850x600 (33.4x23.6)
Permissible mass of workpiece	kg	500	500
Max. workpiece height	mm(in)	800 (31.49)	1033 (40.6)
<b>SPINDLE</b>			
Spindle speed	rpm	10000	10000
Spindle nose (nominal size, NO.)		7/24 Taper, NO. 40	7/24 Taper, NO. 40
Spindle bearing inner diameter	mm(in)	70 (2.7)	70 (2.7)
Max. spindle torque	N.M (ft.lbf)	95 (70)	95 (70)
<b>FEED RATE</b>			
X/Y/Z Rapid traverse	m/min(IPM)	32/28/32 (1259/1102/1259)	32/32/28 (1259/1259/1102)
Feed rate	m/min(IPM)	10 (393)	10 (393)
Max. cutting feed rate	mm/min(IPM)	2000	5000
<b>A.T.C</b>			
Tool storage capacity	pcs	40	30
Max. tool diameter (with adjacent tools)	mm(in)	75 (2.95)	80 (3.15)
Max. tool diameter (without adjacent tools)	mm(in)	125 (4.92)	140 (5.5)
Max. tool length	mm(in)	250 (9.8)	250 (9.8)
Tool change time ( T-T/C-C)	sec	3.5/10	3/10
<b>A.P.C</b>			
Number of pallets		2	2
Pallet changing time	sec	12	12
<b>FEED MOTORS</b>			
Spindle motor (30min/cont.) FANUC	kw(hp)	15/18.5 (20/24.8)	15/18.5 (20/24.8)
X/Y/Z axis feed motors	kw(hp)	7/4/4 (9.3/5/5)	7/4/4 (9.3/5/5)
<b>MACHINE SIZE</b>			
Height of machine (H)	mm(in)	2980 (118)	
Floor space (LXW)	mm(in)	3320x4800 (130x189)	
Total machine weight	kg	15000	10500
Power requirement	KVA	50	50
Controller	FANUC	0i-M	0i-M

AVAILABLE CONTROLLER: SIEMENS

## STANDARD ACCESSORIES

- Spindle oil cooler
- Rigid tapping
- Tool tip air blow system
- Metric table
- Fully enclosure guarding
- Shower coolant
- Chip conveyor inside machine (auger type)
- Chip conveyor outside machine & chip bucket
- Work light
- Alarm lamp
- Heat exchanger
- Remote MPG

## OPTIONAL ACCESSORIES

- 8000rpm spindle
- A.T.C 60 tools magazine
- Two speed gearbox
- C.T.S from A
- Inch table
- Linear scale (X/Y/Z)
- Tool overload detection
- Automatic tool length measurement
- Automatic workpiece measurement
- Simple tool life management
- Coolant gun
- Oil skimmer
- Oil mist collector
- Air conditioner