

The Ultimate in Performance

MCV Series

MCV-1300i S/MCV-1500i/
MCV-1500i +/MCV-2000i

LEADWELL
LEADWELL CNC MACHINES MFG., CORP.

LEADWELL CNC MACHINES MFG., CORP.



No.8, Xingke Road, Houli District, Taichung City 421007, Taiwan
T: 886 - 4 - 25589008
F: 886 - 4 - 25589027
E-mail: sales@leadwell.com.tw

www.leadwell.com.tw

* All performance are based on 220V/3PH/60HZ. Specifications are subject to change without notice.

2020.06



VERTICAL MACHINING CENTERS

Rigid construction, Unsurpassed quality, high accuracy and excellent Performance under severe Machining conditions.

STD

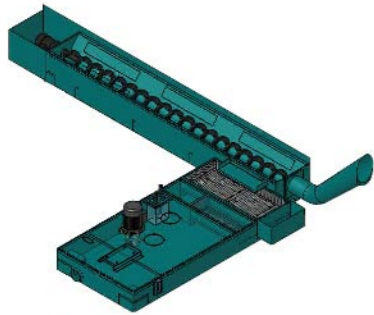

OPT

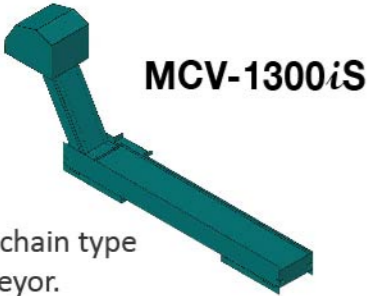

MCV-1300iS

Scraper / chain type chip conveyor.



More Powerful

- Powerful spindle motor
- Massive cast iron base for extra stability
- Wide column design for extra rigidity

Increased capacity

- X travel from 1300 - 2040mm
- Table size from 1420x610mm to 2100x1000mm

Faster/More Productive

- Rapid rates up to 20 m/min
- Spindle speed 4000rpm (6000/8000/10000 rpm optional)

Ergonomic considerations

- Easy to use key-pad control station
- Easy-moving operator door
- No chip or coolant leaks expensive floating tap holders and prevents thread distortion and thread pullout

FEATURE

Cast Iron Construction

LEADWELL uses only top quality well-ribbed castings. Finite Element Analysis (FEA) is used on each new casting to determine the size and location of all internal ribs ensuring high torsional stiffness and minimum vibration. The cast iron base column, saddle, headstock, & tables have over 10 times the dampening capacity of those made from steel resulting in superior cutting performance.

Heavy-Duty Square Ways

The heavy-duty square ways are hardened to HS67-75 (HRC 50-60) and precision ground. The female square ways and gibs are coated with anti-friction Turcite-B. These features allow the machine to maintain maximum accuracy levels.

MCV-1500i



Chip Removal



High efficient front-typed chip conveyor and best coolant tank design with outstanding chip removal.

MCV-1500i/1500i+/2000i opt

Extention Column 400

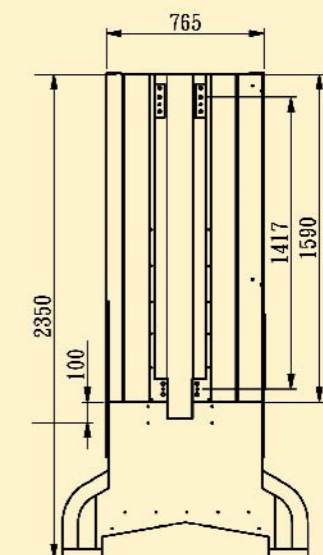

HIGH-PERFORMANCE Standard



Auto Tool Change System



Arm Type Magazine
24 tools / 30 tools(opt.)



Coolant System



Tool Unclamping Oil Cup



3 Axis Pretension



Portable MPG



Ergonomic Design 0-90°
swivel control



Alarm Lamp

24 tools



30 tools



Side-Mounted Tooling System

The tool magazine is isolated from the machining area. An automatic door keeps chips from contaminating the tools' tapered shanks. Having the next tool ready near the spindle during current tool machining drastically reduces tool change time.

Our MCV series also offers the multifarious choice for the ATC system option. We have 24 tools and 30 tools arm type ATC system for different working need.

Automatic Tool Changing System(optional)

The high-speed ATC activates a high-pressure air blast to clean the spindle taper and the ATC tool pot to ensure accurate tool holding. Tools are automatically returned to their original location, eliminating tool interference from oversized tools in the magazine.

STRUCTURE



Directly Coupled Servo Motors

The servo motors are connected to the ball screws with rigid shaft couplings. These couplings ensure that even under severe loading from sharp corner machining, precise interpolation is achieved. This design is superior to both and flexible shaft coupling designs.

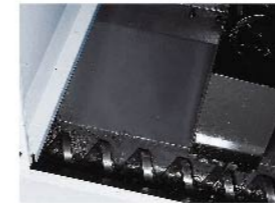

Chip Removal

LEADWELL use chip augers on both sides of the machine and provides high volume coolant to wash the chips from the work area. The augers move the chips into the disposal container, which eliminates the need to from an operator to manually remove chips. This system eliminates operation intervention and reduces non-cutting time.



Double Nut Designed Ball Screws

LEADWELL use only premium quality preloaded double-nut ball screws from the high-quality supplier. And each ball screw is accurately aligned parallel to the guideways and anchored at both ends. They are then pre-tensioned to improve machine stiffness. The rotational torque variations inspected to guarantee a non-binding, highly accurate, and long-running component with this design, it can exceed customer requirements for accuracy and maximum life.



Ball Bar Testing

LEADWELL use a stringent ball bar test that checks not only linear accuracy but also machine geometry. This test ensures that each machine meets the three-dimensional squareness and accuracy requirements.



It is designed for heavy cutting with high removal rate over 400cc/min in S45C material.

HIGH-PRODUCTIVITY Options

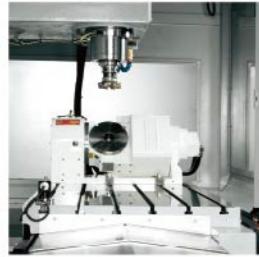

4th & 5th Axis Rotary Table Option

This 4th & 5th axis rotary table option boosts productivity by allowing more machining with a single set-up. It also can turn the machine into a 4 axis contouring machine which adds versatility.



Spindle Annular Coolant Jet with 8 Nozzles Option

This unique spindle annular coolant jet with 8 nozzles option provides a ring around spindle nose where powerful coolant fluid is coming out to cool down/lubricate workpiece and tooling from all sides.



Spindle Probe Option

LEADWELL's spindle probe can automate workpiece setup and inspect parts.



Coolant Through Spindle Option

The optional CTS includes an auxiliary high-pressure pump, which supplies high-pressure coolant to the cutting edge. CTS improves tool life, allows both deep hole drilling and blind pocket milling. It also allows higher speeds, which reduces cycle time.



Programmable Coolant Nozzle Option

This unique programmable coolant nozzle option provides precise coolant control. It allows the NC program to change the coolant direction during the machining cycle. This option eliminated operator adjustment causing unnecessary downtime.



Tool Probe Option

It measures both tool length and tool diameter. It uses macro programming to automatically define and update tool offsets. This option will easy setup and check for broken tools.

HIGH-PRODUCTIVITY Options

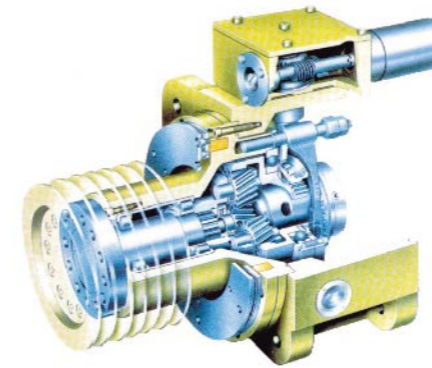

High Torque Spindle Option

The cutting torque is maximized by combining the German ZF two speed gearbox with the oil cooled main spindle. The gearbox has its own separate lubrication system.

Features :

- Over 95% efficiency
- Quiet gears
- Heat is not transmitted to the main spindle
- Gear vibration is not transmitted to the main spindle
- Minimum backlash

FINITE ELEMENT ANALYSIS

Optimum

- Section areas
- Moments of inertia
- Torsional constant
- Plate thickness
- Bending stiffness
- Transverse shear
- Vibration reduce

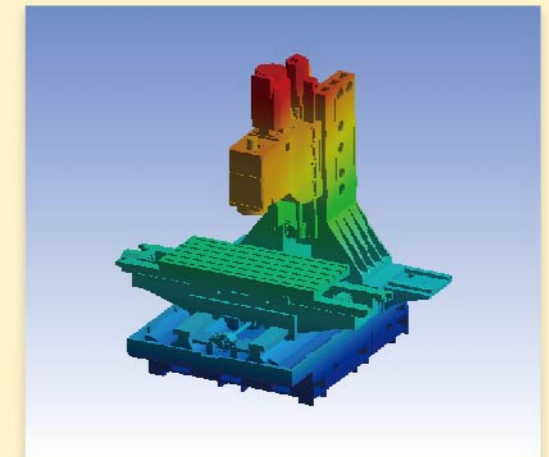

With FEA you can:

1. Predict and improve product performance and reliability.
2. Reduce physical prototyping and Testing.
3. Evaluate different designs and materials.
4. Optimize designs.

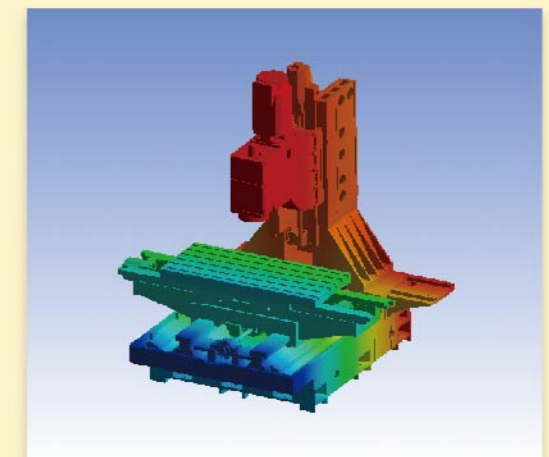

PERFORMANCE

MCV-1300iS

Material: S45C

FACE MILL	
Removal Rate	440cc/min.
Tool	Ø125mm
Spindle Speed	1500rpm
Feed Rate	1100mm/min
Width of Cut	100mm
Depth of Cut	4mm

END-MILL	
Removal Rate	170cc/min.
Tool	Ø20mm
Spindle Speed	1750rpm
Feed Rate	500mm/min
Width of Cut	17mm
Depth of Cut	20mm

U-DRILL	
Removal Rate	196cc/min.
Tool	Ø50mm
Spindle Speed	1500rpm
Feed Rate	100mm/min
Depth of Cut	30mm

RIGID TAP	
Tapping	M20
Spindle Speed	600rpm
Feed Rate	1500mm/min.

LEADWELL SMART PROCESSOR

More than a machine

Leadwell is never simply about building a machine and to launch onto the market. Our years of experience, we learn that the right programs must be developed to ensure the competitiveness of the users.

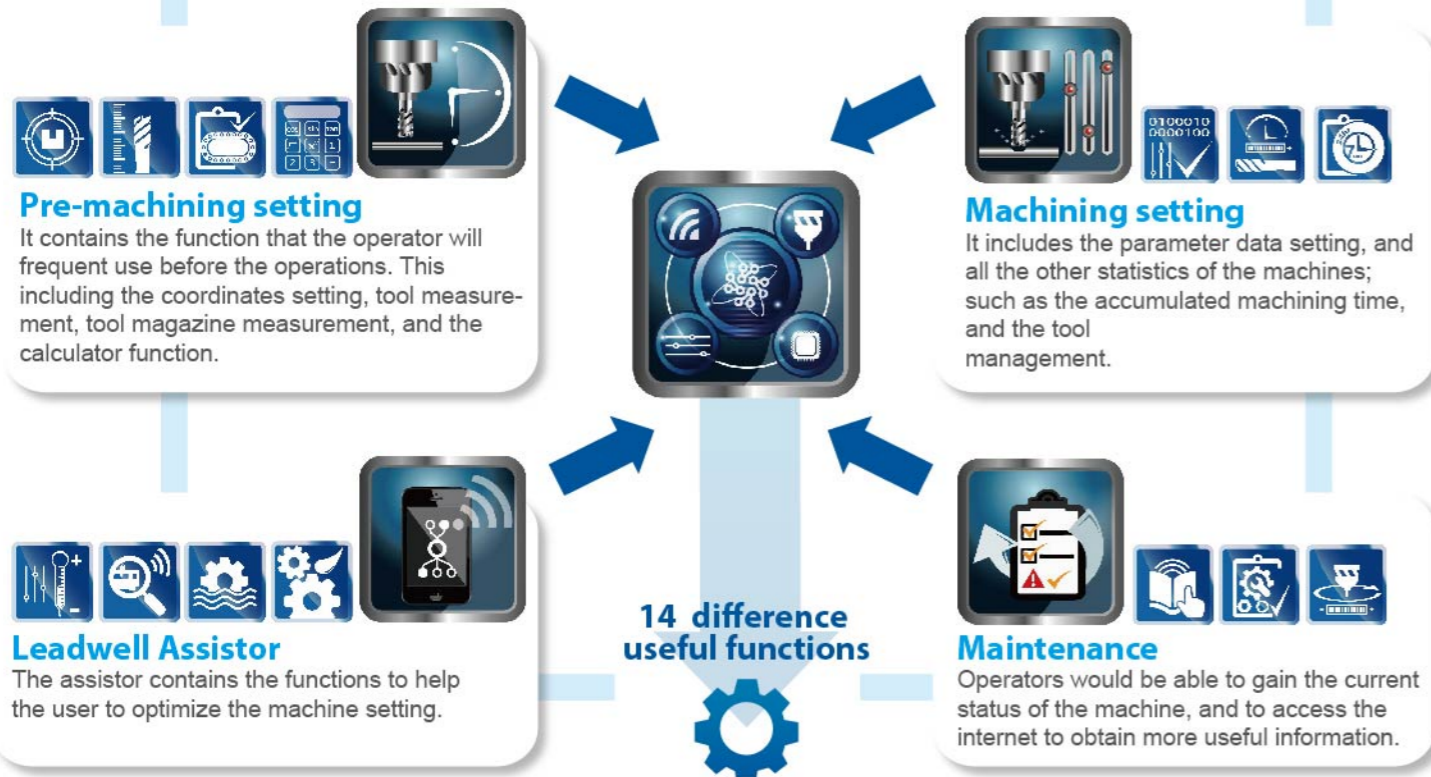

Users' full satisfaction have always been Leadwell's main focus.

SPINDLE POWER CURVE

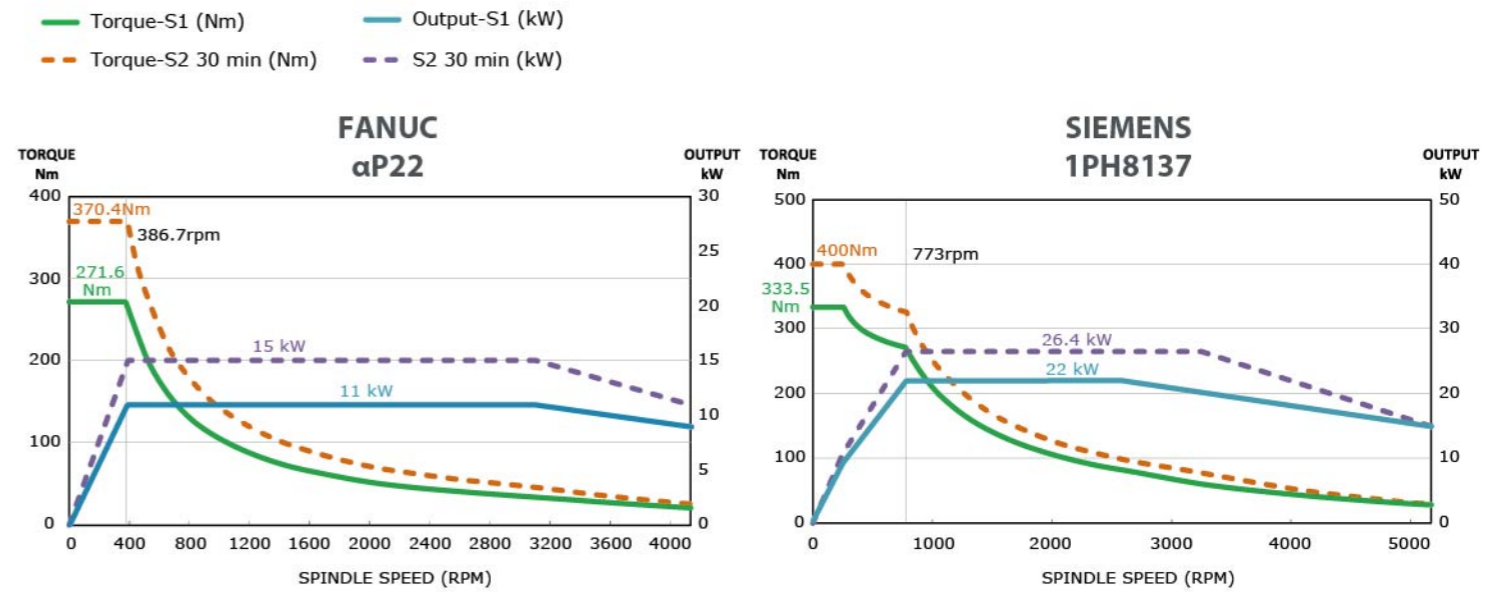
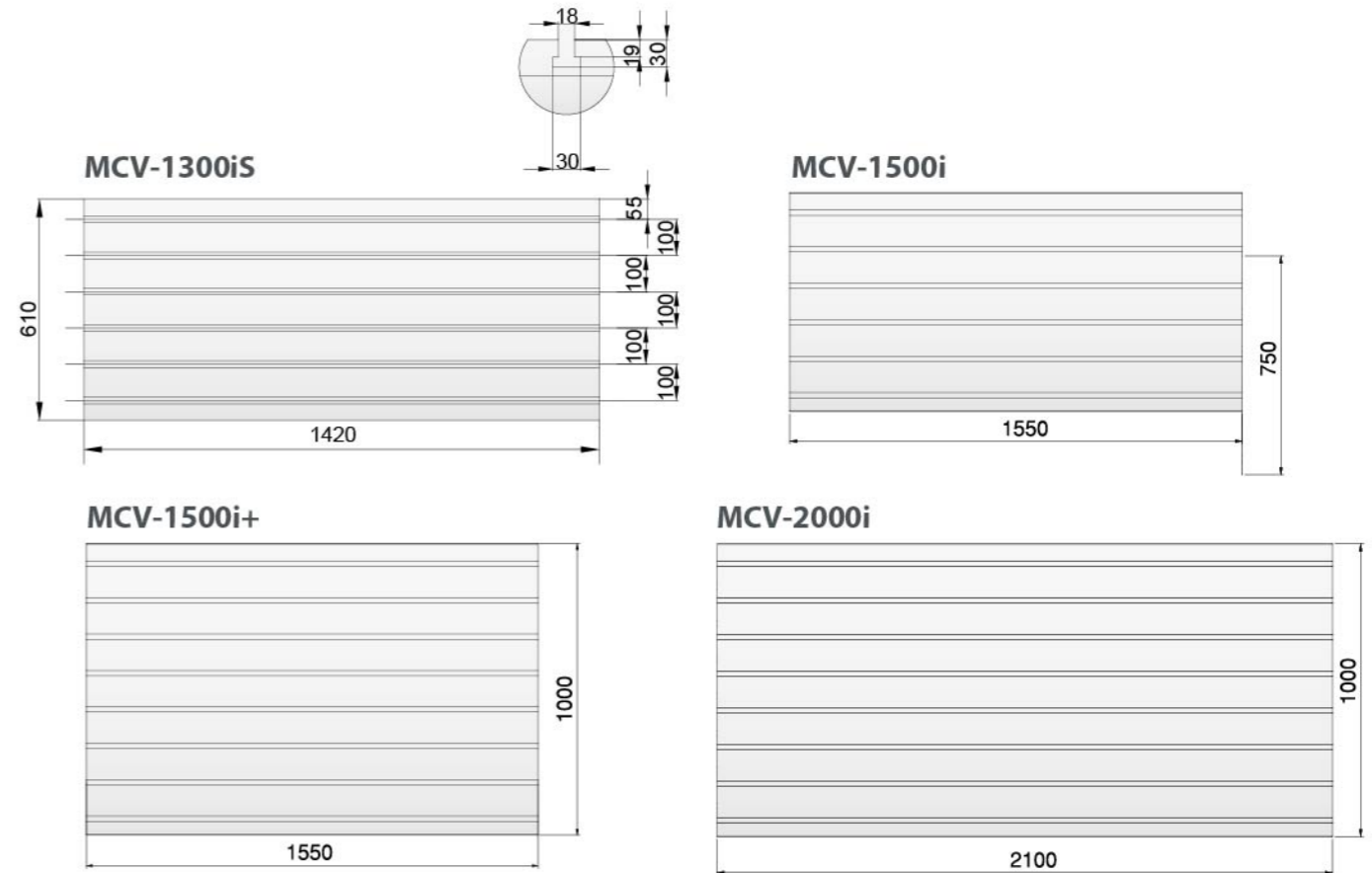

TABLE DIMENSION



INTERNAL DIMENSION

MCV-1300iS

unit: mm

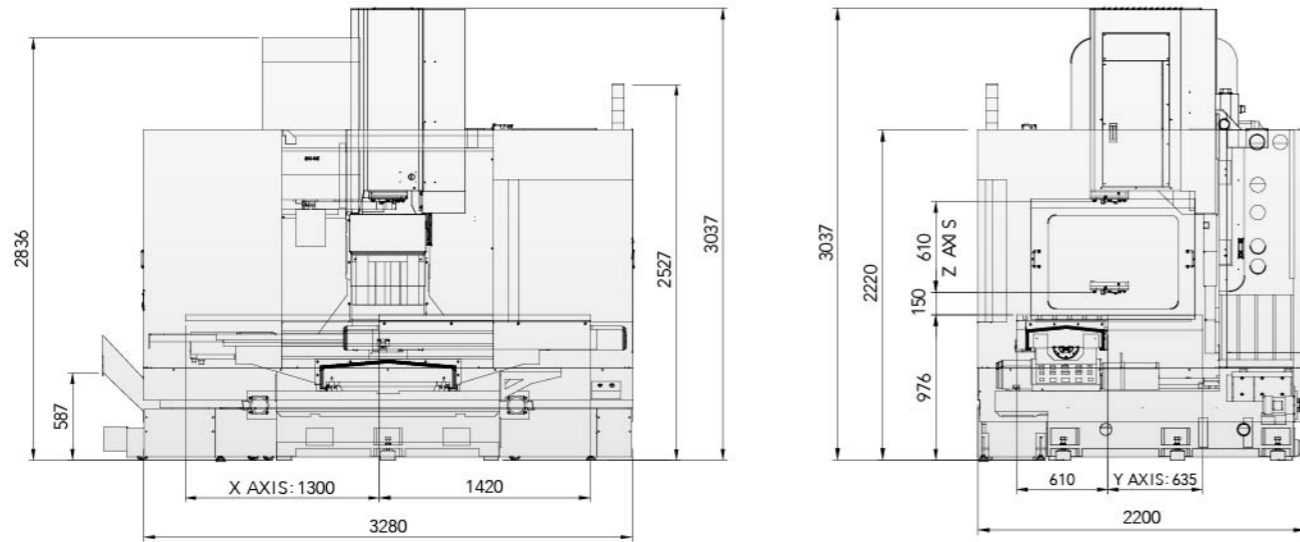

MCV-1500i

unit: mm

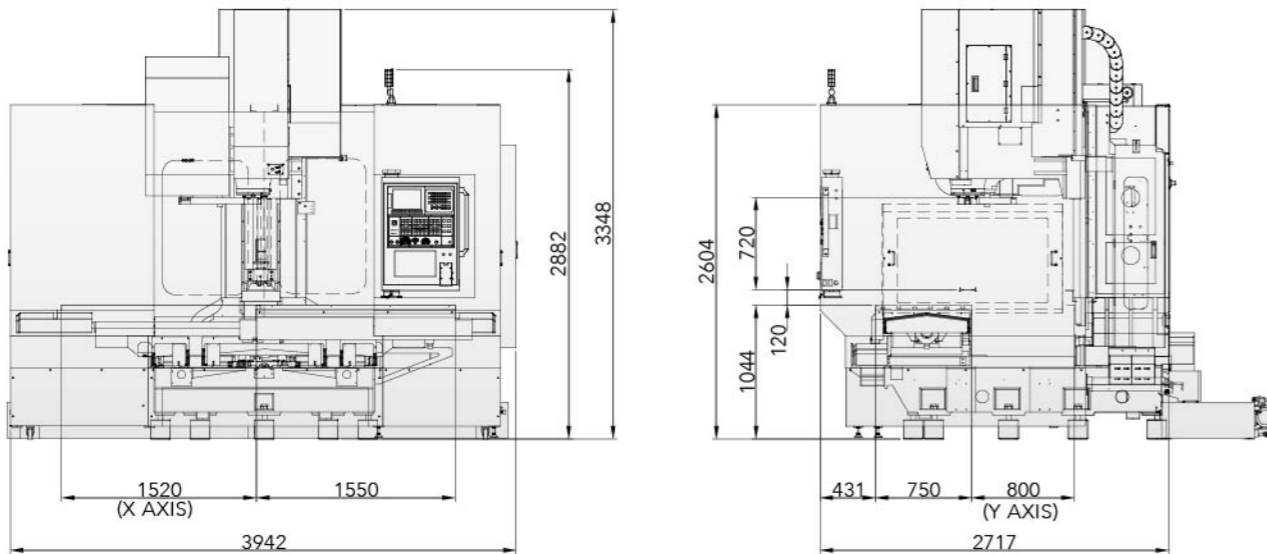

INTERNAL DIMENSION

MCV-1500i+

unit: mm

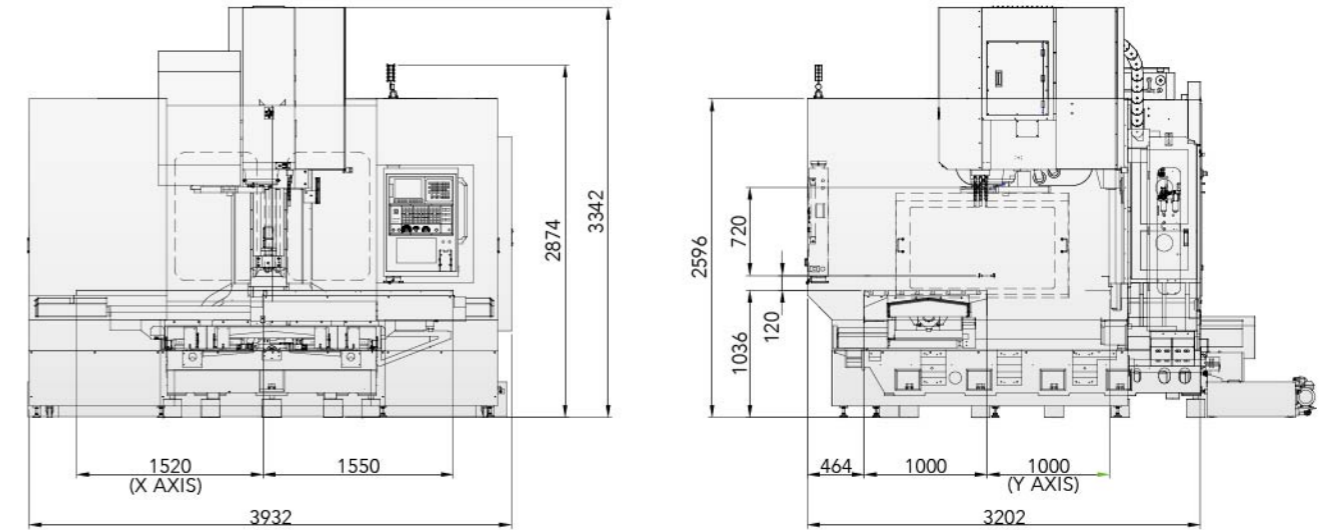

MCV-2000i

unit: mm

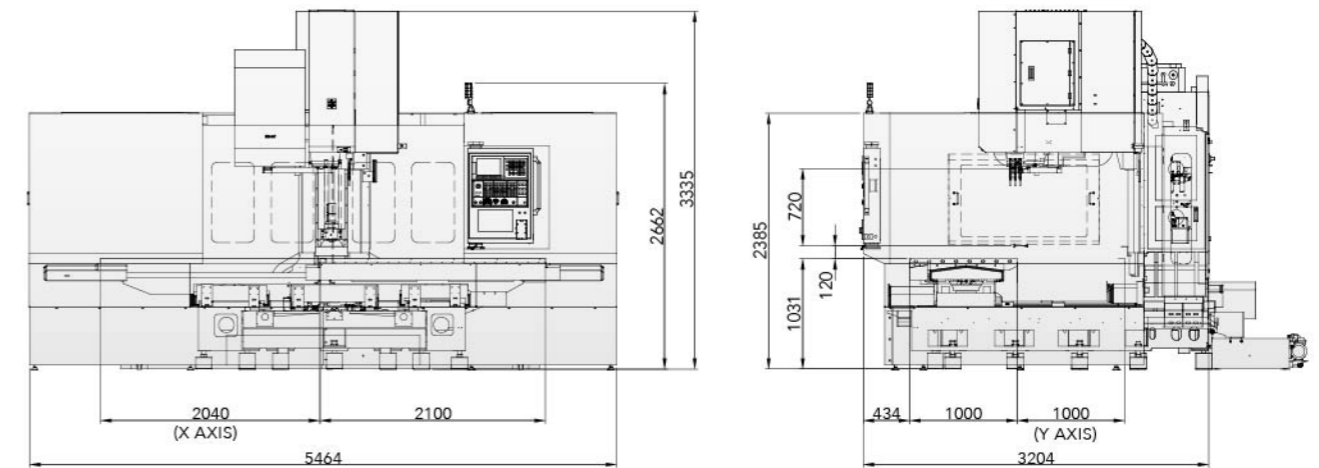

OUTLINE DIMENSION

MCV-1300iS

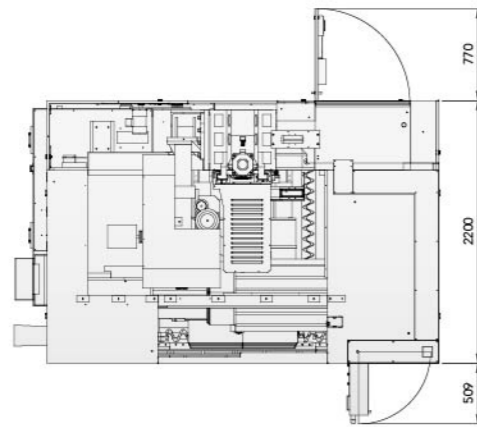

unit: mm

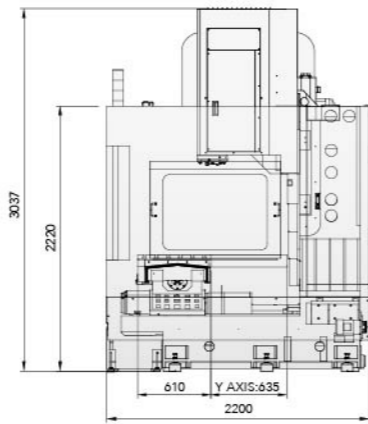
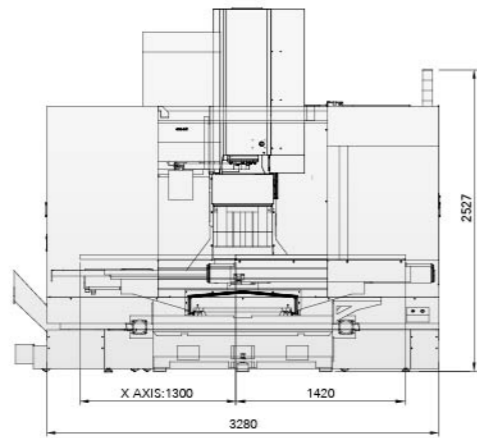

MCV-1500i

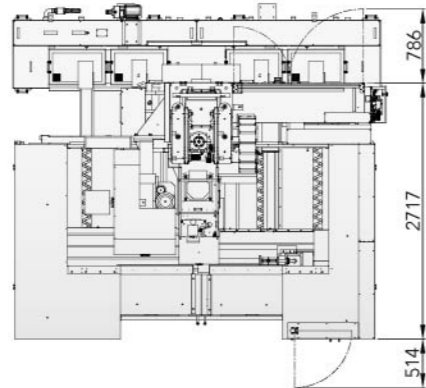

unit: mm

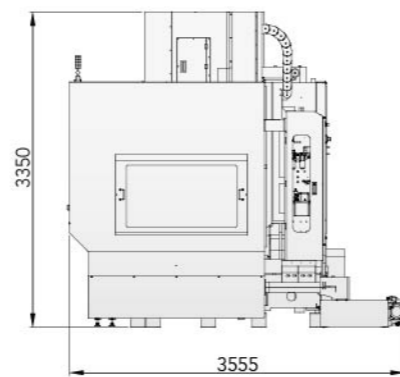
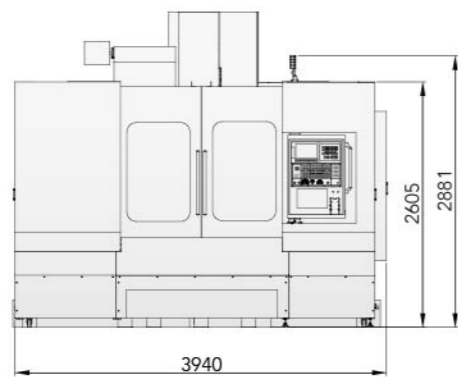

OUTLINE DIMENSION

MCV-1500i+

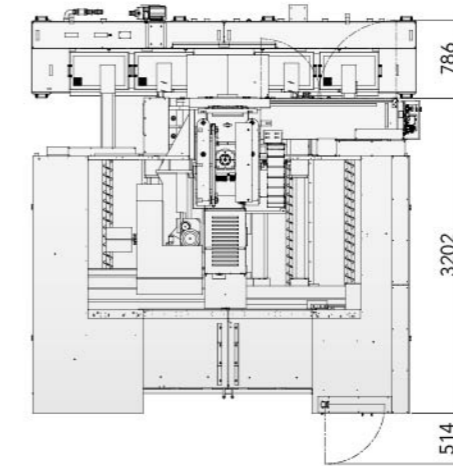

unit: mm

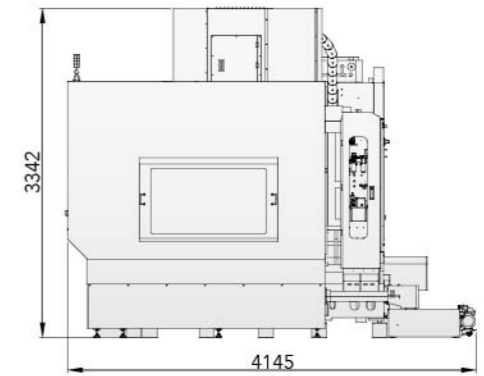
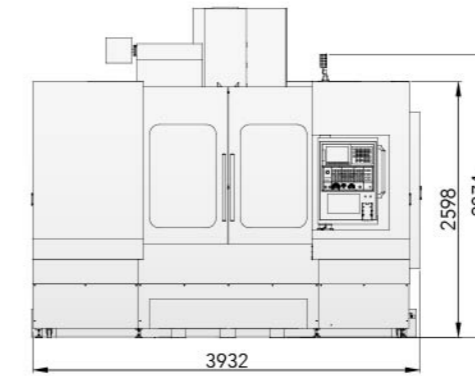

MCV-2000i

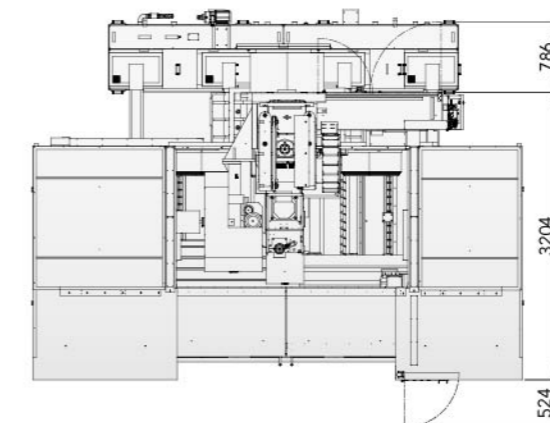

unit: mm

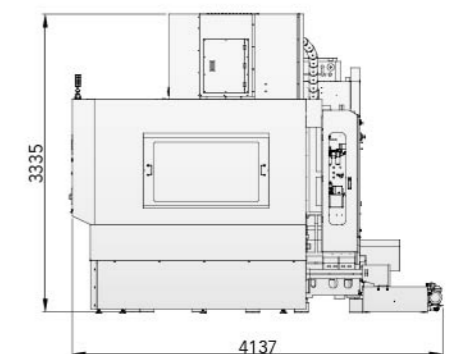
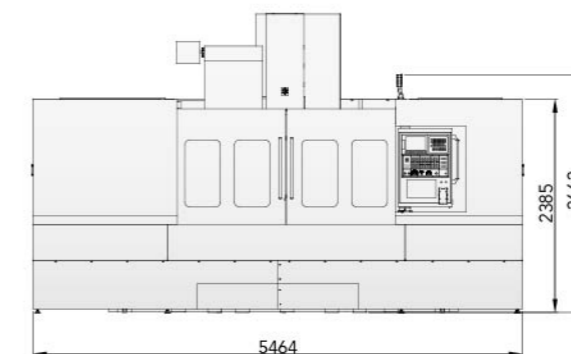

MACHINE SPECIFICATIONS

ITEM	MODEL	MCV-1300iS	MCV-1500i	MCV-1500i+	MCV-2000i
A.T.C.	Type	ARM	ARM	ARM	ARM
CAPACITY	Unit				
X axis travel	mm (in)	1300 (52)	1520 (59.8)	1520 (59.8)	2040 (80.3)
Y axis travel	mm (in)	635 (25)	800 (31.5)	1000 (40)	1000 (40)
Z axis travel	mm (in)	610 (24)	720 (28.3)	720 (28.3)	720 (28.3)
Distance from table top to spindle end	mm (in)	160-770 (6.2-30.3)		120-840 (4.8-33)	
Distance from column front to spindle center	mm (in)	635 (25)	760 (30)	1000 (40)	1000 (40)
TABLE					
Table size (LxW)	mm (in)	1420x610 (56x24)	1550x750 (61x29.5)	1550x1000 (61x40)	2100x1000 (72.7x40)
Max. table load weight	kg	1000	1300	1300	2000
T-slot size	mm	18Tx100x6	18Tx125x6	18Tx125x8	
SPINDLE					
Spindle speed	rpm	4000, 6000 OPT			
Spindle nose (nominal size, No.)		7/24 Taper, NO.50			
Spindle bearing inner diameter	mm	90 (3.54)	90 (3.54)	90 (3.54)	90 (3.54)
FEED RATE					
Rapid traverse X,Y,Z	m/min(ipm)	24/24/20 (944.9/944.9/787)		20/20/20 (787/787/787)	
Max. cutting feed rate	m/min(ipm)	10 (394)	5 (196.8)	5 (196.8)	5 (196.8)
A.T.C.					
Tool storage capacity	pcs	24			
Max. tool diameter (with adjacent tools)	mm (in)	100 (4)			
Max. tool length	mm (in)	300 (11.8)			
Tool change time T-T(C-C)	sec	3 (6)	3 (10)		
MOTORS					
Spindle motor (30min) FANUC	Kw(hp)	15 (20)			
X,Y,Z axis motor	Kw(hp)	4/4/7 (5.4/5.4/9.3)	4/4/4 (5.4/5.4/5.4)		
MACHINE SIZE					
Height of machine (H)	mm (in)	2721 (107)	3006 (118)	3343 (131.6)	3334 (131)
Floor space (LxW)	mm (in)	3840x2200 (151x86.6)	3820x4365 (150x171.8)	3840x2200 (151.2x86.6)	5466x4135 (215x163)
Total machine weight	Kg	7000	11000	13250	16520
Power requirement	KVA	35	35	35	35
Controller	FANUC	Oi -M			

*AVAILABLE CONTROLLER:SIEMENS/FAGOR/HEIDENHAIN



MACHINE ACCESSORIES

ITEM	MODEL	MCV-1300iS	MCV-1500i	MCV-1500i+	MCV-2000i
Full enclosure guarding		●	●	●	●
Chip conveyor (auger type)		●	●	●	●
Work light		●	●	●	●
Alarm lamp		●	●	●	●
Heat exchanger		●	●	●	●
Rigid tapping		●	●	●	●
Auto counter for work piece		●	●	●	●
Remote MPG		●	●	●	●
Spindle air purge		●	●	●	●
6000rpm spindle		■	■	■	■
10000rpm spindle		■	■	■	■
Spindle oil chiller		■	■	■	■
Two speed gearbox		■	■	■	■
C.T.S From A		■	■	■	■
Linear scale		■	▲	▲	▲
Tool overload detection		■	■	■	■
Auto tool length measurement (A.T.L.M)		■	■	■	■
Automatic workpiece measurement		■	▲	▲	▲
Simple tool life management		■	▲	▲	▲
Oil skimmer		■	▲	▲	▲
Chip conveyor & chip bucket		■	■	■	■
Coolant gun		■	■	■	■
Air conditioner		■	▲	▲	▲
Rotary table preparation		■	■	■	■
Manual tailstock for rotary table		■	▲	▲	■
Through hole drill kit		■	■	■	■
DNC link software		■	▲	▲	▲
Programmable nozzle		■	x	■	■
Auto door		▲	x	x	x
ARM 30T ATC		▲	▲	▲	▲
Table guarding		▲	x	x	x

● : S.T.D / ■ : O.P.T (DESIGNED) / ▲ : O.P.T (TO BE ADVISED) / x : N/A(NOT AVAILABLE)