



High Efficiency Machining Center

## VE Series

V-22iF(iR)/V-30iF(iR)  
V-32iF(iR)/V-32AF(AR)  
V-42iF(iR)/V-42AF(AR)  
V-52AF(AR)

**LEADWELL**  
LEADWELL CNC MACHINES MFG., CORP.



**LEADWELL CNC MACHINES MFG., CORP.**



No. 23 Gong 33th Road, Taichung Industrial Park  
Taichung 407, Taiwan  
T: 886 - 4 - 23591880  
F: 886 - 4 - 23592555  
E: sales@leadwell.com.tw

[www.leadwell.com.tw](http://www.leadwell.com.tw)

\* All performance are based on 220V/3PH/60HZ. Specifications are subject to change without notice.

2019.03



## High Efficiency

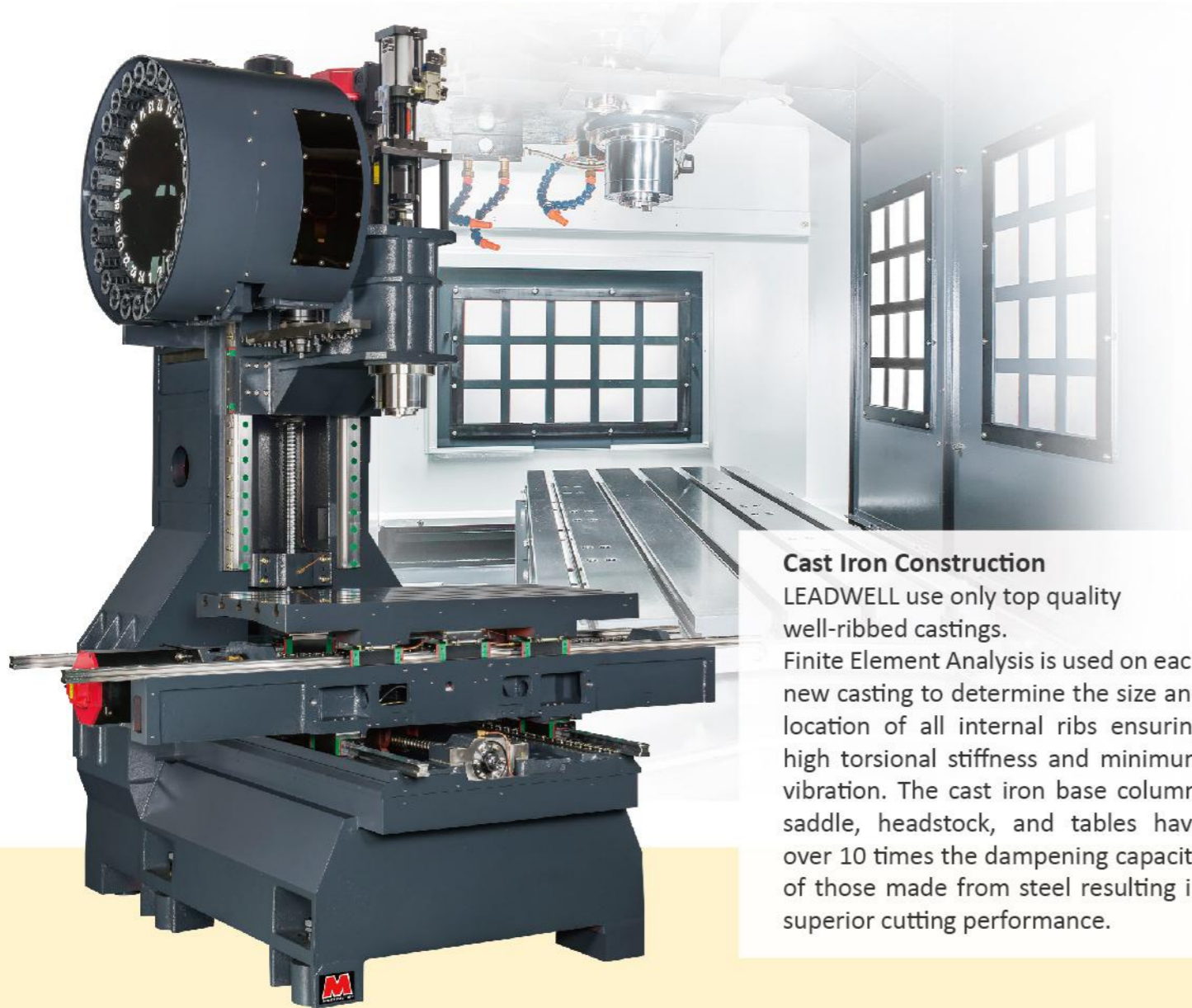

**Cast Iron Construction**  
LEADWELL use only top quality well-ribbed castings. Finite Element Analysis is used on each new casting to determine the size and location of all internal ribs ensuring high torsional stiffness and minimum vibration. The cast iron base column, saddle, headstock, and tables have over 10 times the dampening capacity of those made from steel resulting in superior cutting performance.

### High Rigidity:

- FEA Analysis
- The rigidity of the table increased by 50%
- High rigidity structure design
- 3 Axis ball screw prestressing
- A type of Z-axis column

### High Reliability:

- Roller type motion system
- 3 Axis absolute motor

### High Efficiency:

- V-32A.V-42A.V-52A with high torque spindle motor
- Rapid feed rate 48/48/36 mm
- Spindle speed 12,000 rpm(optional)
- Tool change time T to T 1.8 sec
- Tool change time C to C 4 sec

### High Flexibility:

- 30 tools magazine available
- 4/5 axis rotary table available
- Front/Rear Chip Disposal available



### Directly Coupled Servo Motors

The servo motors are connected to the ball screws with rigid shaft couplings. These couplings ensure that even under severe loading from sharp corner machining, precise interpolation is achieved. This design is superior to both and flexible shaft coupling designs.

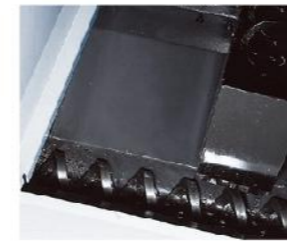

### Chip Removal (V-32/42/52 SERIES)

LEADWELL use chip augers on both sides of the machine and provides high volume coolant to wash the chips from the work area. The augers move the chips into the disposal container, which eliminates the need to from an operator to manually remove chips. This system eliminates operation intervention and reduces non-cutting time.



### Linear Guide Ways

LEADWELL use linear guideways that feature zero clearance and fully-loaded carrying capacity in all directions. The ways consume less power and require no adjustments. They linear guideways outperform all other types of ways used today. Additionally, each way is automatically lubricated independently to increase life.



### Ball Bar Testing

LEADWELL use a stringent ball bar test that checks not only linear accuracy but also machine geometry. This test ensures that each machine meets the three-dimensional squareness and accuracy requirements.

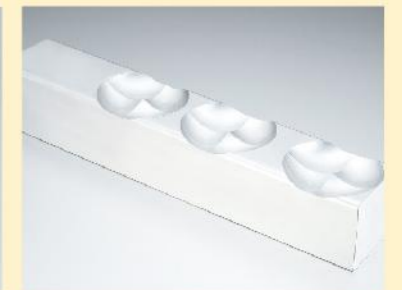
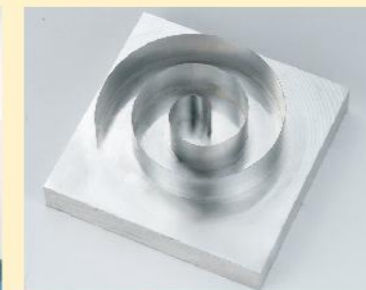



# FINITE ELEMENT ANALYSIS

## Optimum

- Section areas
- Moments of inertia
- Torsional constant
- Plate thickness
- Bending stiffness
- Transverse shear
- Vibration reduce

## With FEA you can:

1. Predict and improve product performance and reliability.
2. Reduce physical prototyping and testing .
3. Evaluate different designs and materials .
4. Optimize designs .

V-22 SERIES

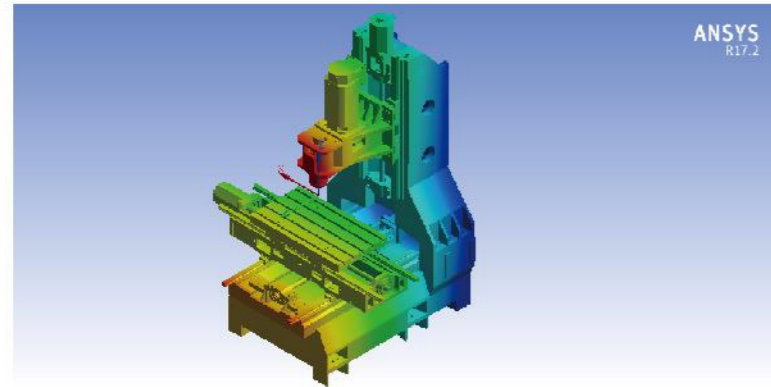
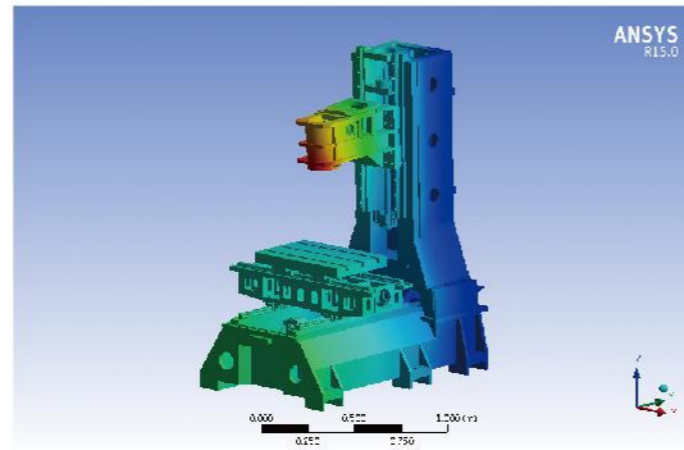

V-32 SERIES

V-42 SERIES

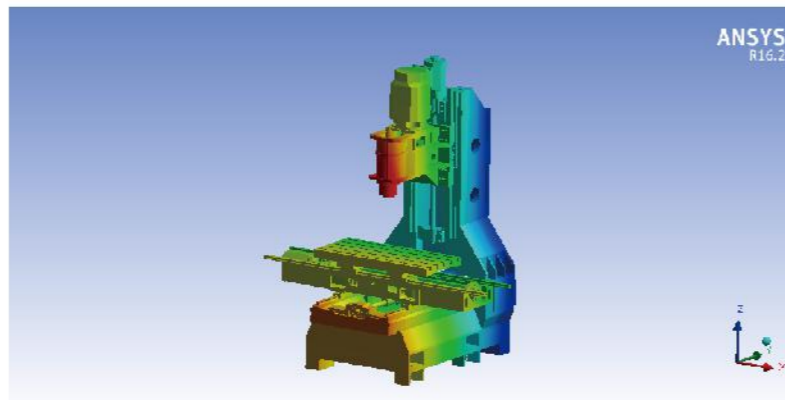

# PERFORMANCE

## V-42iF/iR

**FACE MILL**

Removal Rate **260cc/min.**

Tool Ø63mm

Spindle Speed 1500rpm

Feed Rate 1300mm/min

Width of Cut 50mm

Depth of Cut 4mm

**END-DRILL**

Removal Rate **144cc/min.**

Tool Ø20mm

Spindle Speed 2800rpm

Feed Rate 900mm/min

Width of Cut 20mm

Depth of Cut 8mm

**U-DRILL**

Drilling **Ø42mm**

Tool Ø42mm

Spindle Speed 1500rpm

Feed Rate 130mm/min.

Depth of Cut 50mm

**TAP**

Tapping **M16**

Spindle Speed 350rpm

Feed Rate 700mm/min.

**RIGID TAP**

Tapping **M20**

Spindle Speed 1500rpm

Feed Rate 3750mm/min.

**MATERIAL**

**S45C**

## NASA REPORT

TEST REPORT		YEAR		
		10	2	
MODEL		V-42i		
NUMBER		#011		
DATE		2013/5/18		
PERSONNEL		Thomas		
ITEM	NASA TEXT	MODEL	YEAR	
TEST CONDITION	Material: Aluminum #6061	Finish Machining: Tool: Ø12 End Mill	10 2 4 1 1 2 0 0 1 1	
	Rough Machining: Tool: Ø50 End Mill	Speed: 8000RPM		
TEST RESULT	Speed: 8000RPM	Feed rate: 2000mm/min		
	Feedrate: 3000mm/min			
		<b>Tolerance</b>	<b>Side</b>	<b>Measured</b>
	H	0.015/300	A\B	*
	//	0.015/140	a\c	0.006/140
	//	0.015/140	b\d	0.003/140
	//	0.015/200	g\e	0.002/200
	//	0.015/200	f\h	0.007/200
	⊥	0.015/200	g\f	0.002/200
	⊥	0.015/200	f\e	0.001/200
	⊥	0.015/200	e\h	0.001/200
	⊥	0.015/200	h\g	0.002/200
⊥	0.015/140	a\b	0.001/140	
⊥	0.015/140	b\c	0.006/140	
⊥	0.015/140	c\d	0.003/140	
	<b>Tolerance</b>	<b>Side</b>	<b>Measured</b>	
	0.015/140	d\a	0.002/140	
	17.7	i\k	17.7019	
	13.2	m\n	13.2743	
	0.015/200	abcd	0.001	
	0.015/200	efgh	0.001	
	0.005	C	0.014	
	Ra 2	abcd	△△△3.2	
	Ra 2	A\B	△△△3.2	
	L 141.42mm	A\C	140.217	
	L 141.42mm	D\B	140.221	
	L 200, mm	E\G	198.794	
	L 200, mm	F\H	198.801	

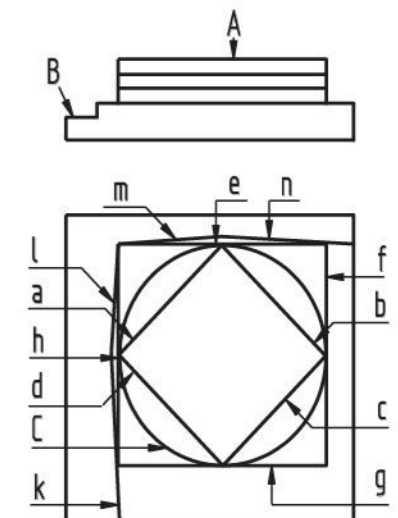



## HIGH-EFFICIENCY Standard



**Auto Tool Change System**



**Arm Type Magazine**  
24 tools / 30 tools(opt.)



**Coolant System**



**Tool Unclamping Oil Cup**

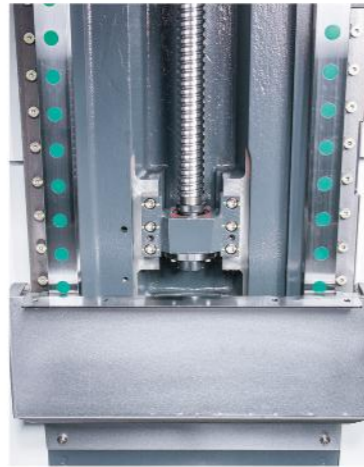

**High Speed Roller Bearing Guide Way**



**3 Axis Pretension**



**Ergonomic Design**  
0-90° swivel control



**Portable MPG**



**Alarm Lamp**

## HIGH -EFFICIENCY Options

### 4th & 5th Axis Rotary Table Option

This 4th & 5th axis rotary table option boosts productivity by allowing more machining with a single set-up. It also can turn the machine into a 4 axis contouring machine which adds versatility.



### Tool Probe Option

It measures both tool length and tool diameter. It uses macro programming to automatically define and update tool offsets. This option will easy setup and check for broken tools.

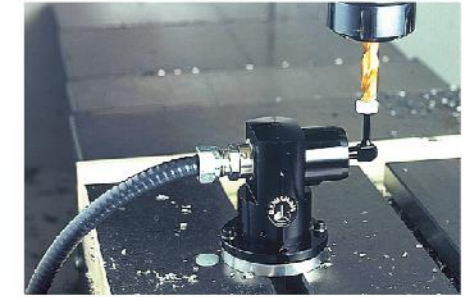

### Programmable Coolant Nozzle Option

This unique programmable coolant nozzle option provides precise coolant control. It allows the NC program to change the coolant direction during the machining cycle. This option eliminated operator adjustment causing unnecessary downtime.

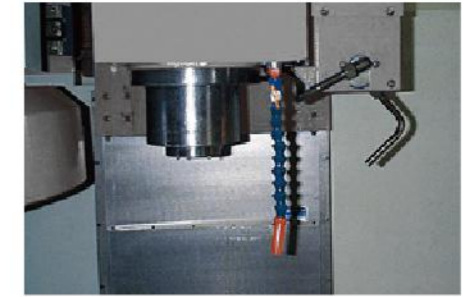

### Coolant Through Spindle Option

The optional CTS includes an auxiliary high-pressure pump, which supplies high-pressure coolant to the cutting edge. CTS improves tool life, allows both deep hole drilling and blind pocket milling. It also allows higher speeds, which reduces cycle time.



### High Torque Spindle Option

The cutting torque is maximized by combining the German ZF two speed gearbox with the oil cooled main spindle. The gearbox has its own separate lubrication system.

#### Features :

- Over 95% efficiency
- Quiet gears
- Heat is not transmitted to the main spindle
- Gear vibration is not transmitted to the main spindle
- Minimum backlash

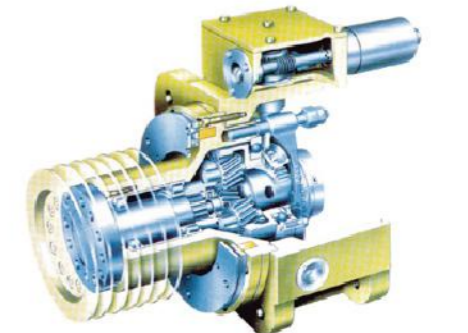



# HIGH -EFFICIENCY Options



Direct Drive Spindle  
12000/15000 rpm



20 Bar High Pressure Pump



Spindle Annular Coolant  
Jet with 8 Nozzles



Automatic Workpiece  
Measurement



Spindle Probe



Oil Skimmer



Spindle Head  
Cooling System

# SPINDLE POWER CURVE

- Continuous N-m
- 30 min N-m
- Coutinuous KW
- 30 min KW

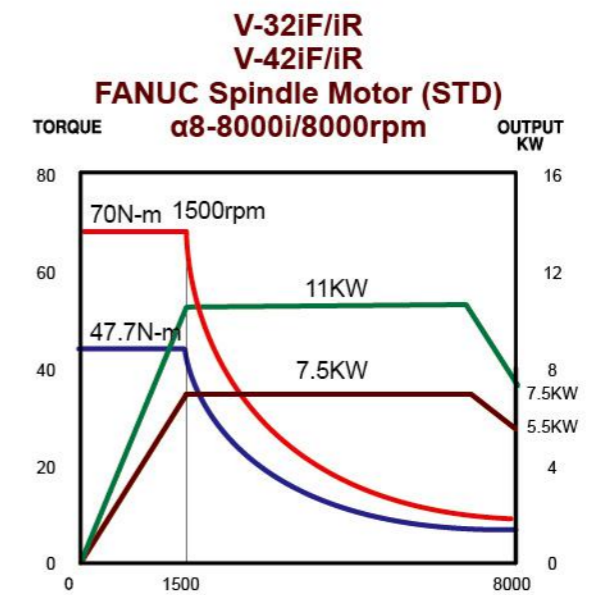
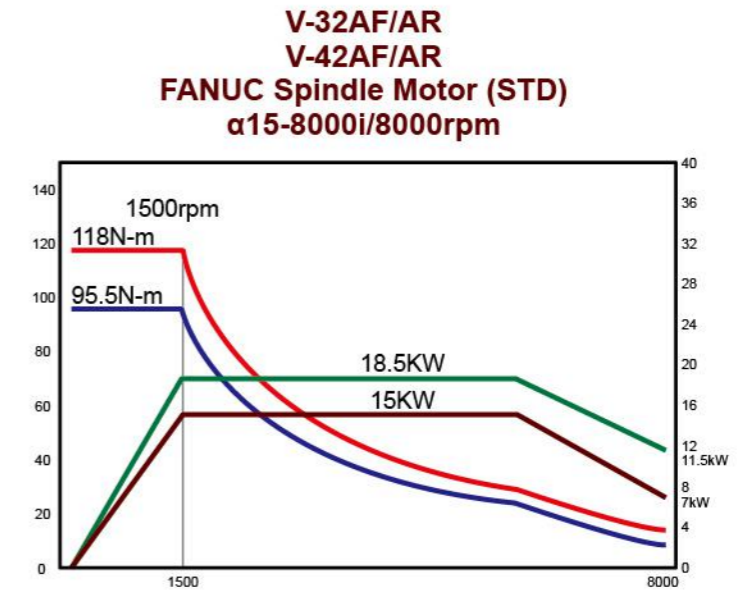
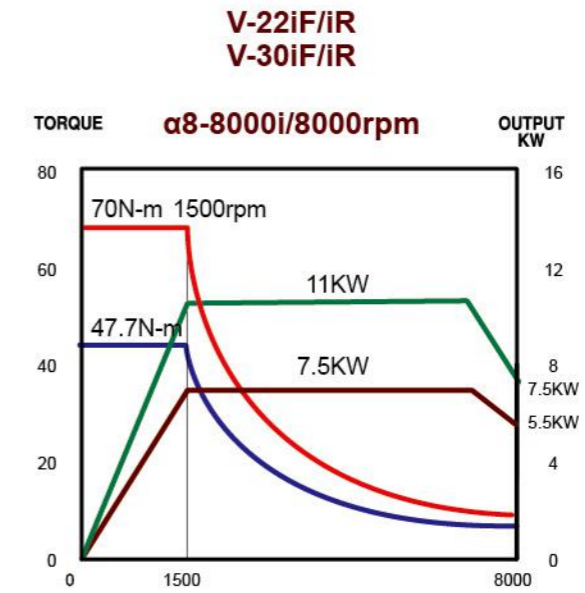

# SPINDLE POWER CURVE

- Continuous N-m
- 30 min N-m
- Continuous KW
- 30 min KW

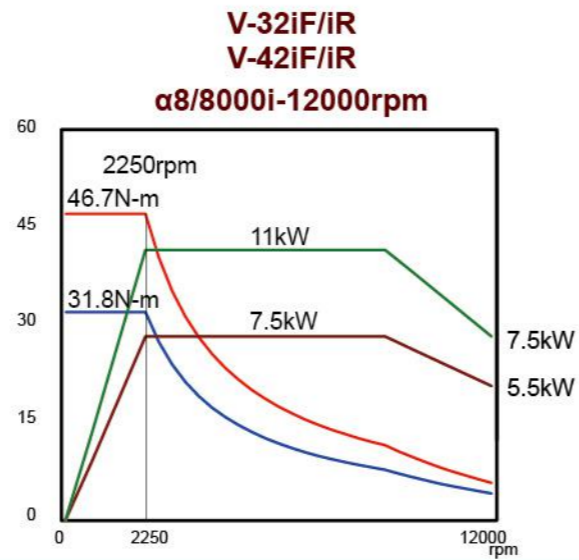
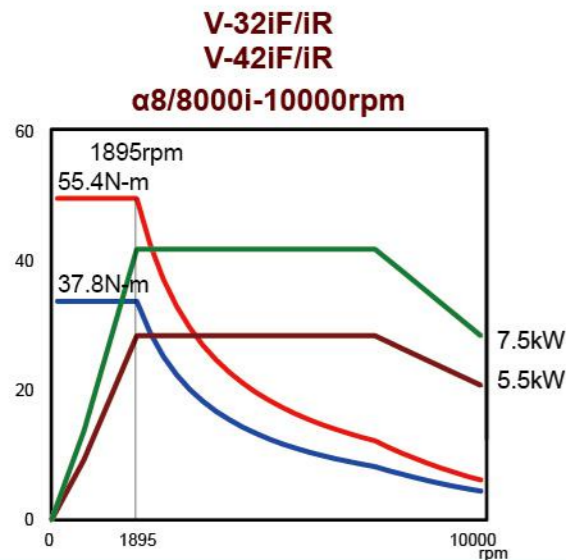
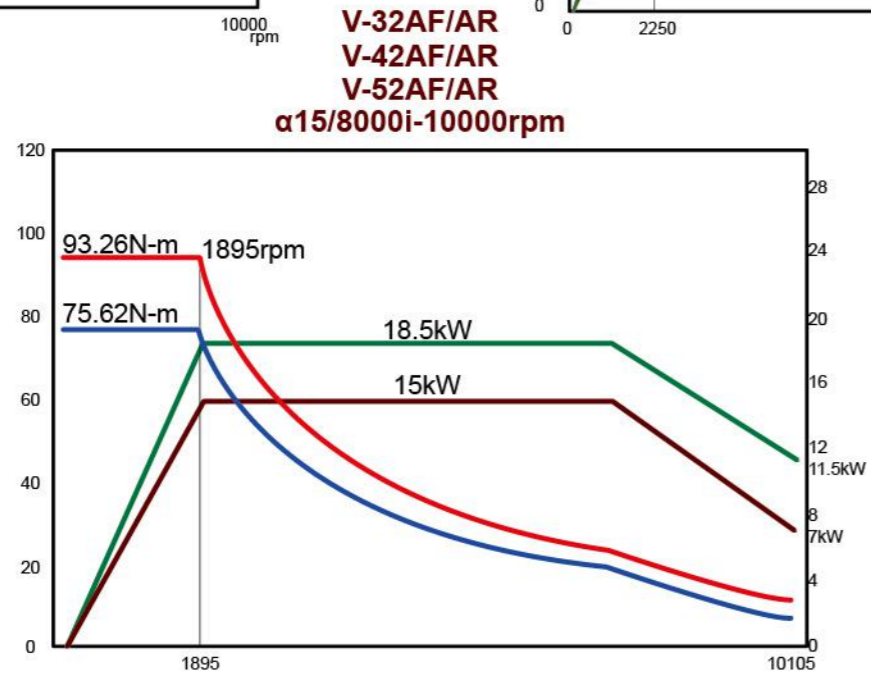
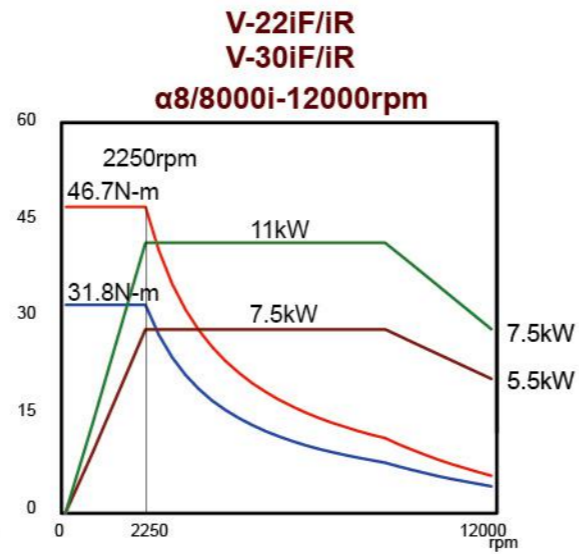
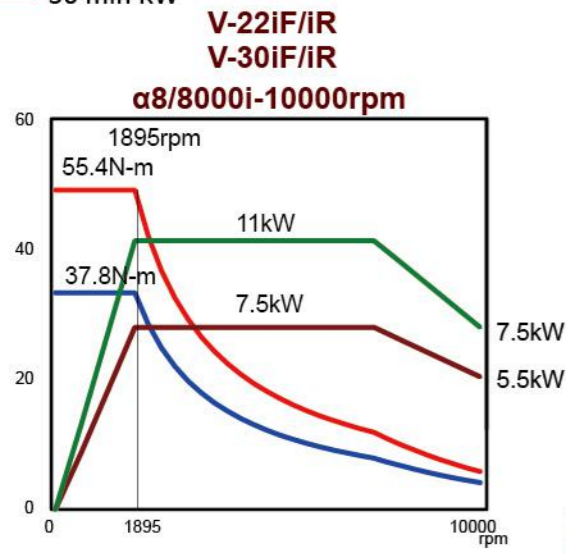

# INTERNAL DIMENSION

## Table Size

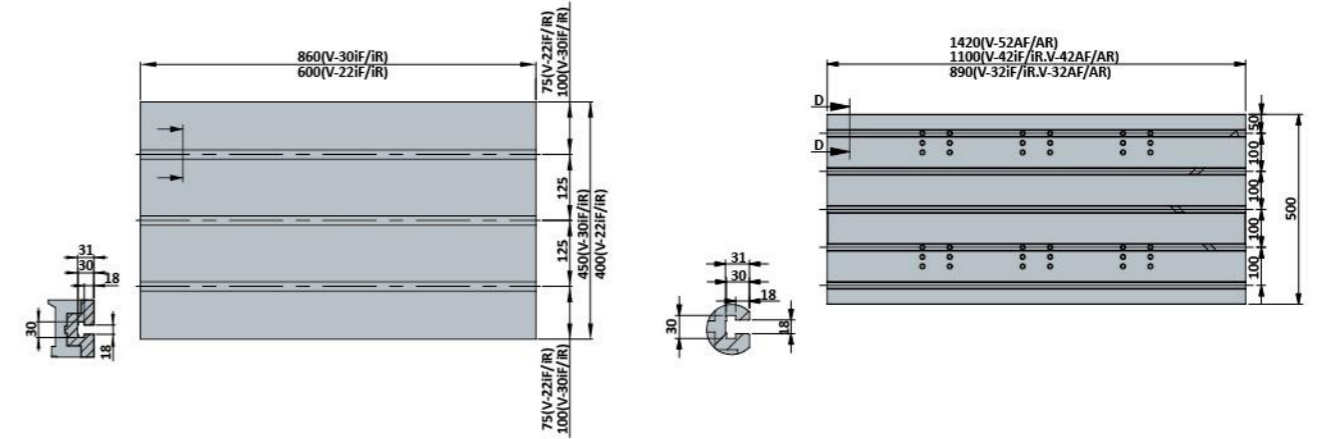

## Travel Drawing

### V-22i/V-30i (FRONT)

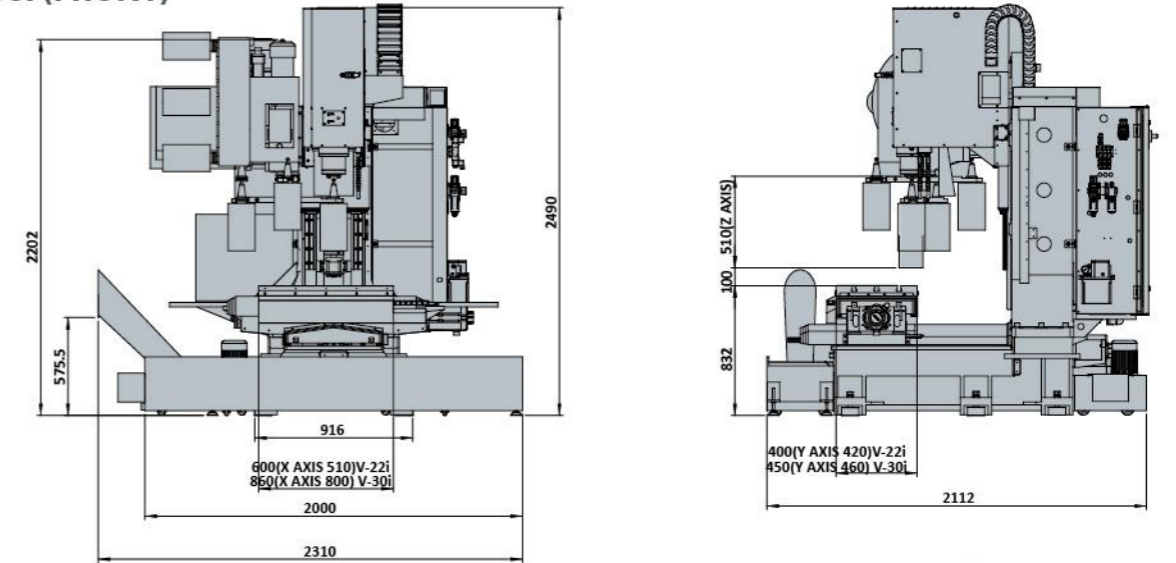

### V-32i/V-42i(REAR) V-32A/V-42A(REAR) V-52A(REAR)

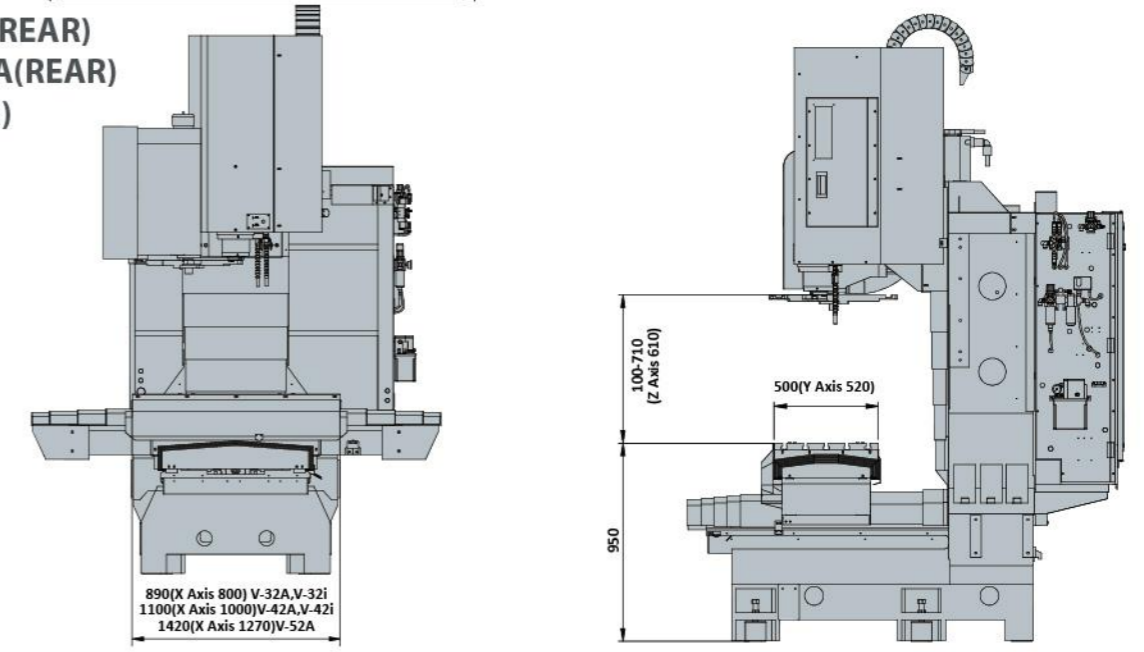



# OUTLINE DIMENSION

V-22iF/V-30iF

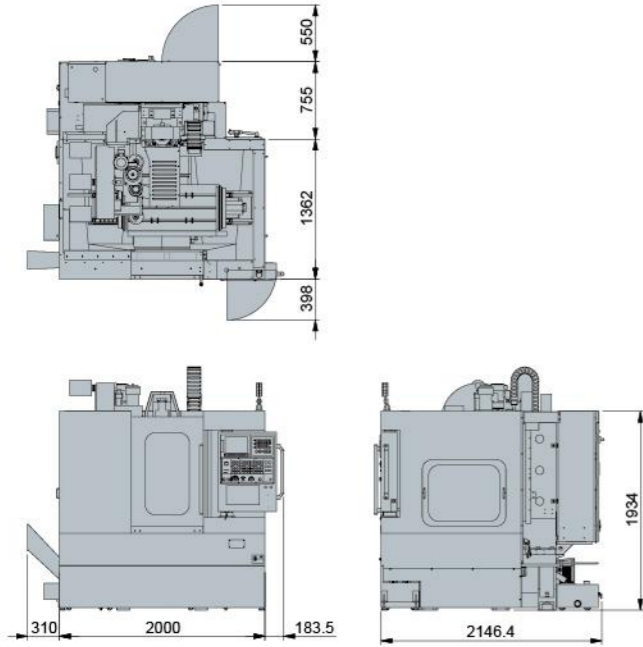

V-22iR/V-30iR

unit: mm

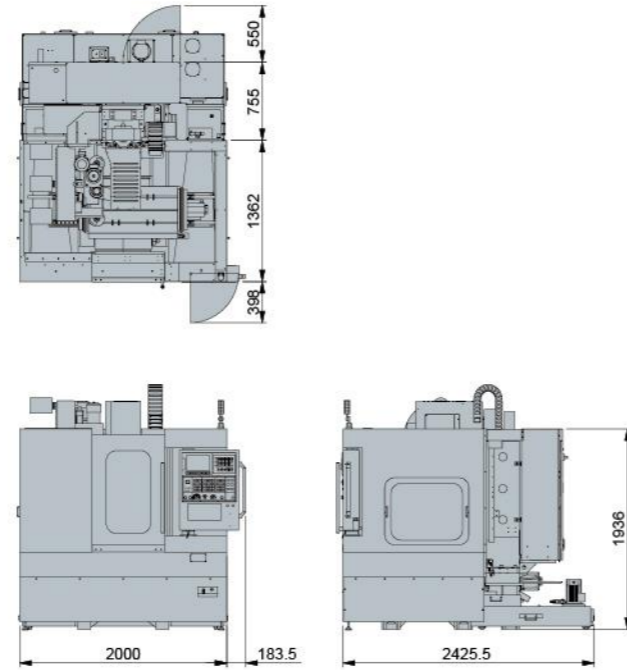

V-32iR/V-32AR

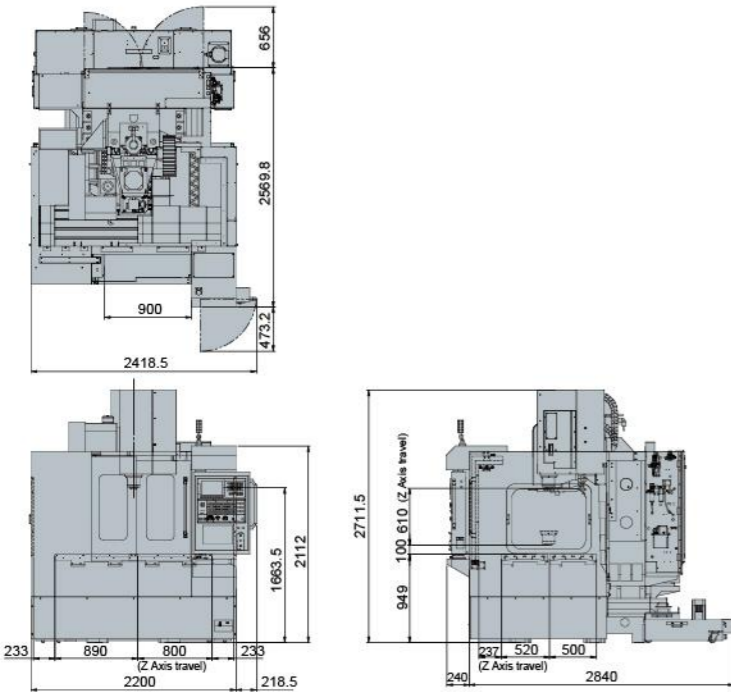

V-32iF/V-32AF

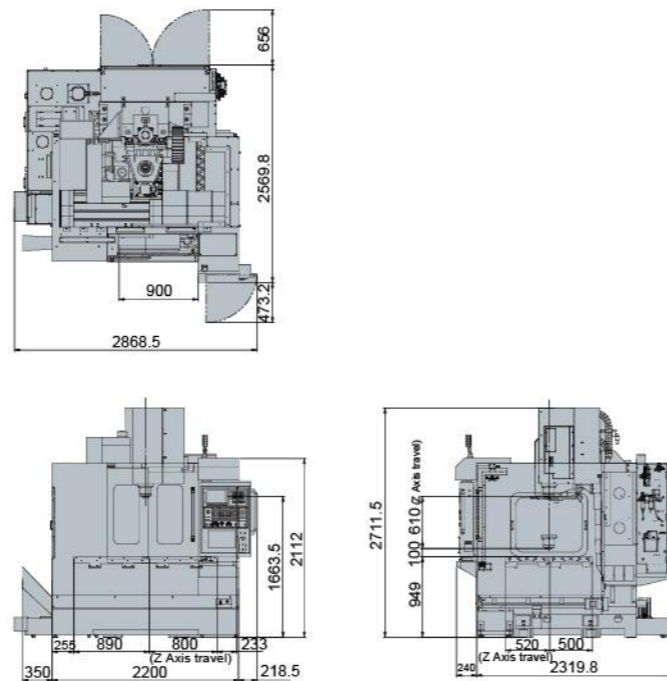

# OUTLINE DIMENSION

V-42iR /V-42AR

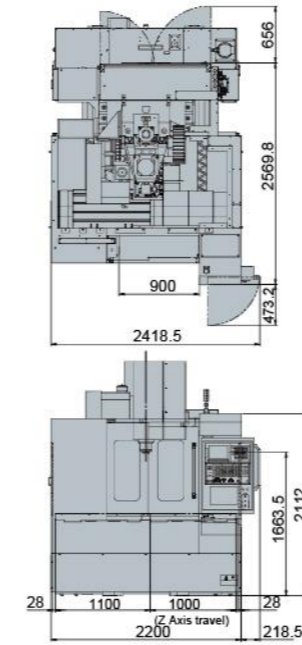

V-42iF/V-42AF

unit: mm

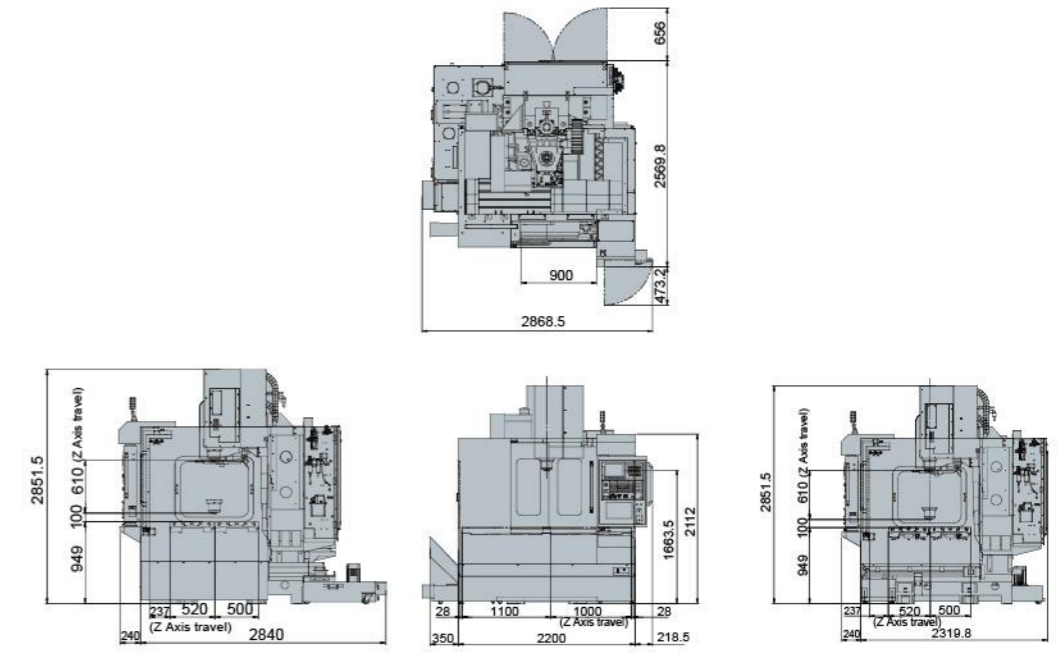

V-52AF

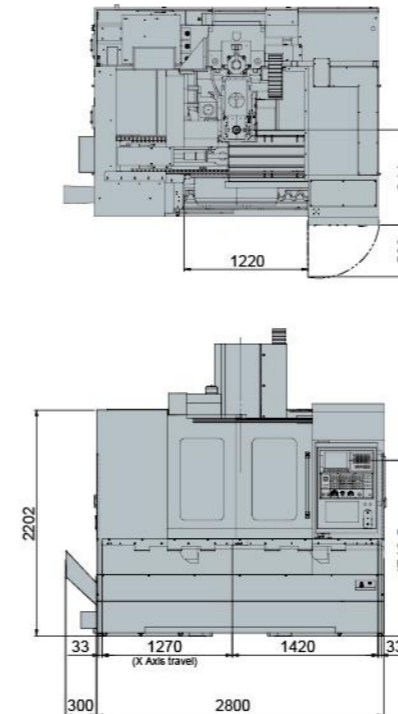

V-52AR

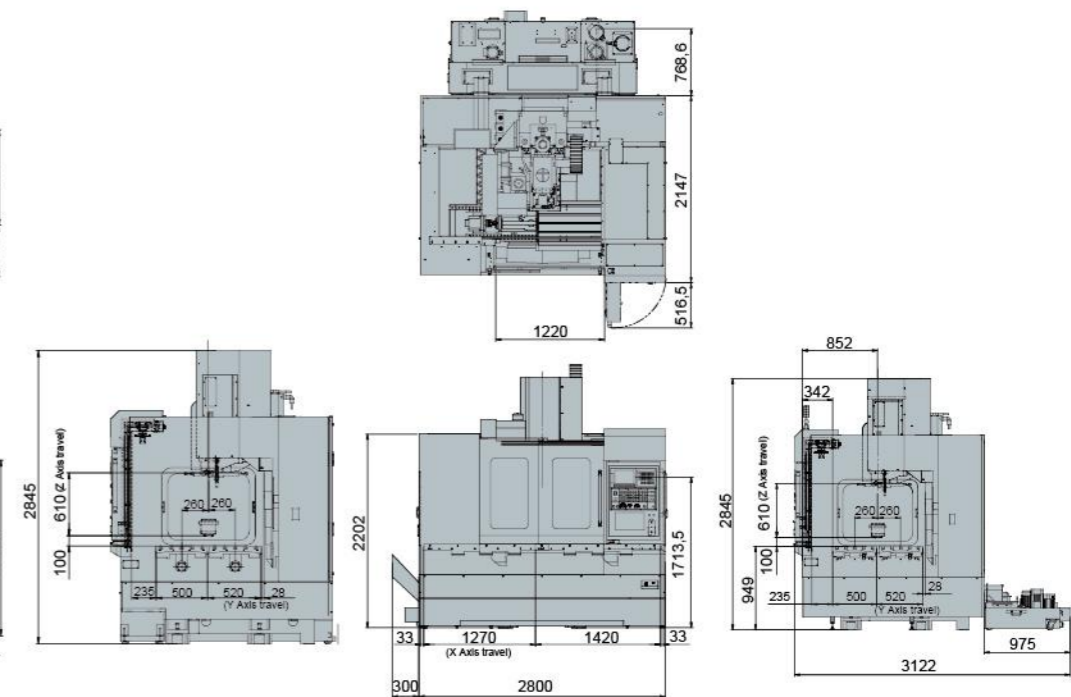



# VERTICAL MACHINING CENTERS

# HIGH PERFORMANCE ROTARY TABLE

## Pull Stud

Standard

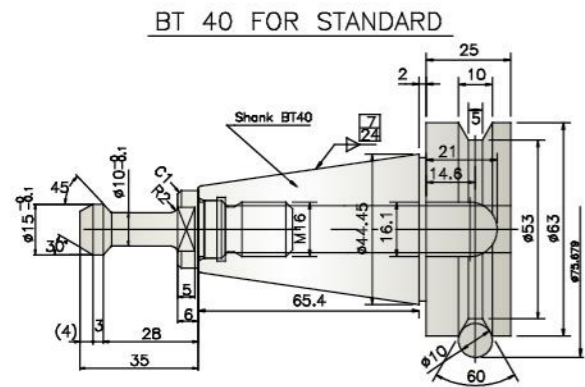

Optional

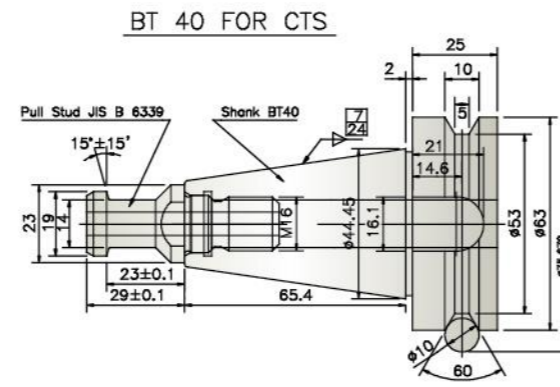

Optional

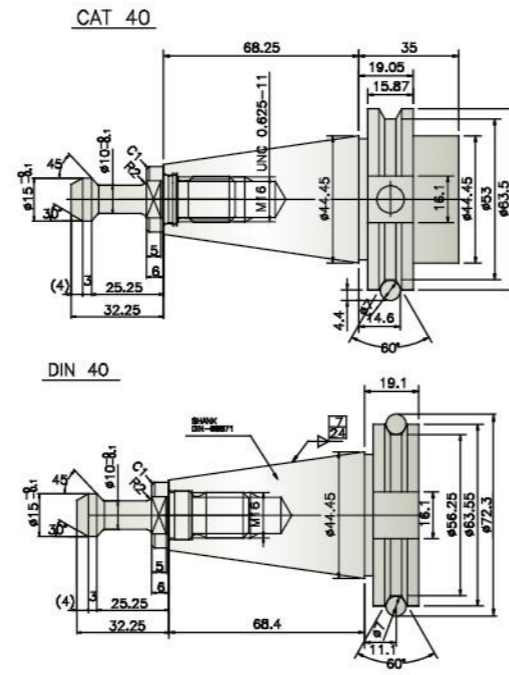
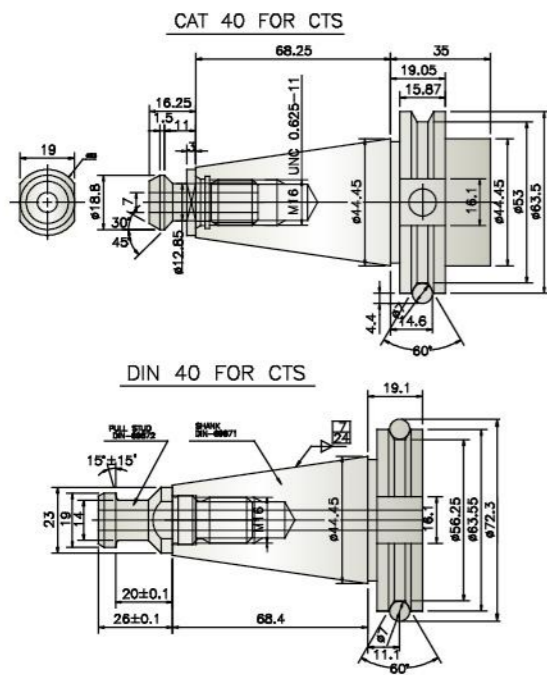

## Cartridge Type Spindle



## BBT Two face contact

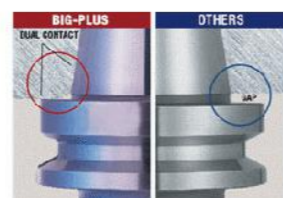

# LEADWELL®

## LWAR Series (Air Brake) LWHR Series (Hydraulic Brake)

LWAR-210/250  
LWHR-210/255/320

● Recommend HR Series to use  
**made-in-Japan** dual-lead worm  
and worm gear

Larger Through Hole → Bigger Bearing  
Bigger Bearing → Higher Rigidity



Large diameter



LWAR-210R

## Devised by German

Specialized for Rotary Table, the Radial & Axial bearing can fully support heavy-duty cutting in both radial and axial directions.



LWHR-255R

(Sheet Metal Cover for Both Vertical and Horizontal Applications)



## Made in Japan(opt)

Unique high tensile brass  
Wear life is 2.6 times longer than aluminum bronze PBC3.

## 4th Ratable Suggest Table

Model	Air			Hydraulic	
V-22iF/iR	LWAR-125R	LWAR-170R	LWAR-210R		
V-30iF/iR	LWAR-170R	LWAR-210R	LWAR-250R	LWHR-210R	
V-32iF/iR/AF/AR	LWAR-210R	LWAR-250R		LWHR-210R	LWHR-255N
V-42iF/iR/AF/AR	LWAR-210R	LWAR-250R		LWHR-210R	LWHR-255N
V-52AF/AR	LWAR-210R	LWAR-250R		LWHR-210R	LWHR-255N



# LEADWELL SMART PROCESSOR

## More than a machine

Leadwell is never simply about building a machine and to launch onto the market. Our years of experience, we learn that the right programs must be developed to ensure the competitiveness of the users.

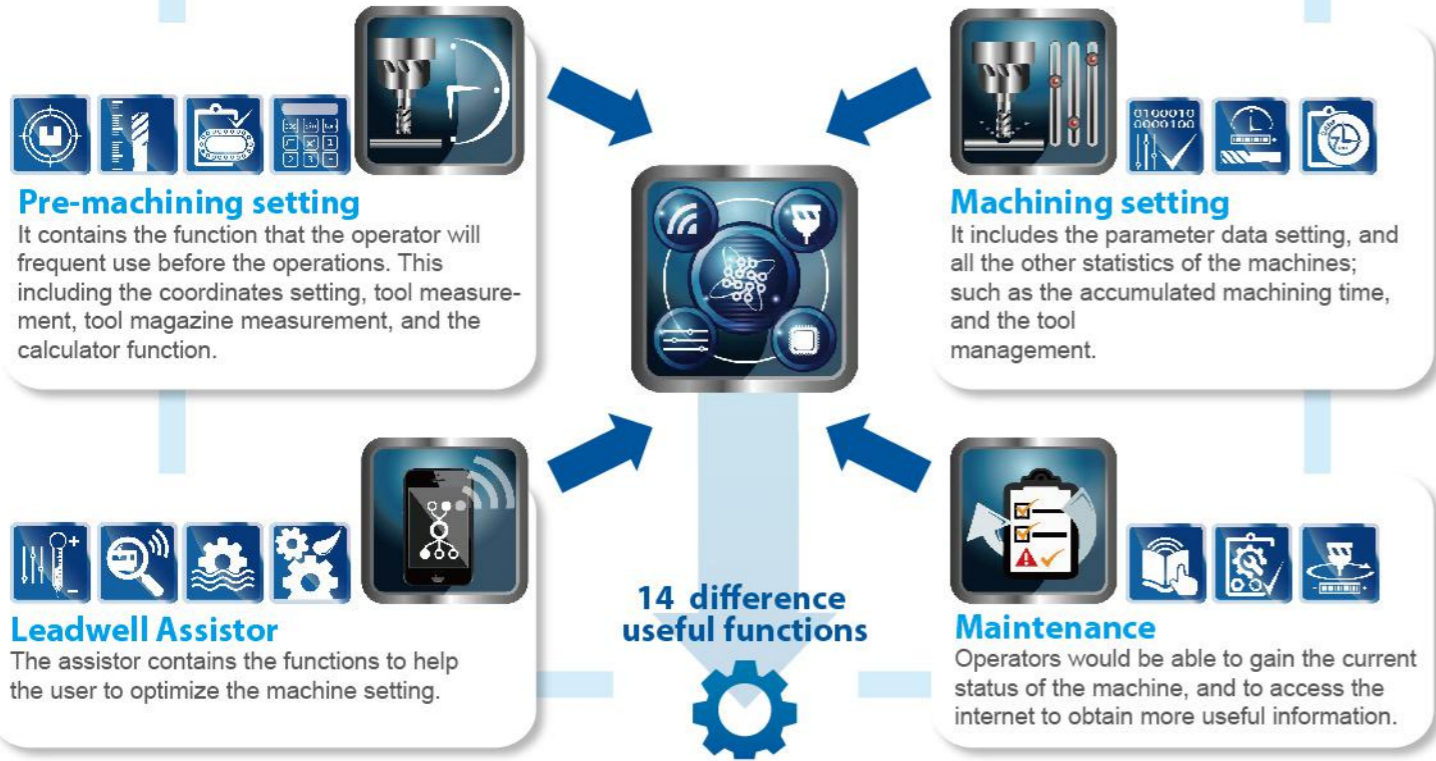

### Pre-machining setting

It contains the function that the operator will frequent use before the operations. This including the coordinates setting, tool measurement, tool magazine measurement, and the calculator function.

### Machining setting

It includes the parameter data setting, and all the other statistics of the machines; such as the accumulated machining time, and the tool management.

### Leadwell Assistor

The assistor contains the functions to help the user to optimize the machine setting.

### Maintenance

Operators would be able to gain the current status of the machine, and to access the internet to obtain more useful information.

14 difference useful functions

## Machined work pieces.

Users' full satisfaction have always been Leadwell's main focus.

# COOLANT AND CHIP SEPERATION SYSTEM

## Rear Chip Disposal

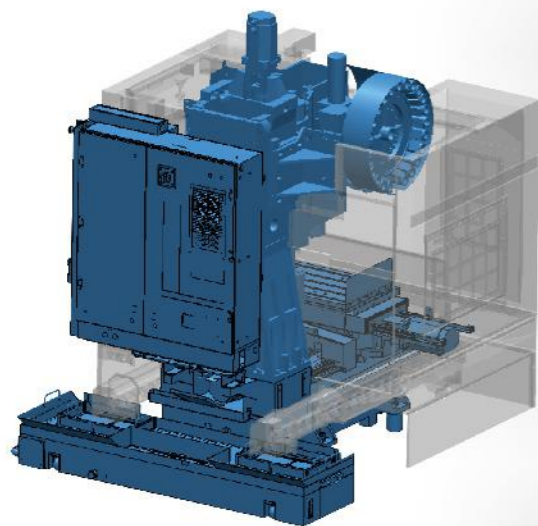

## Front Chip Disposal

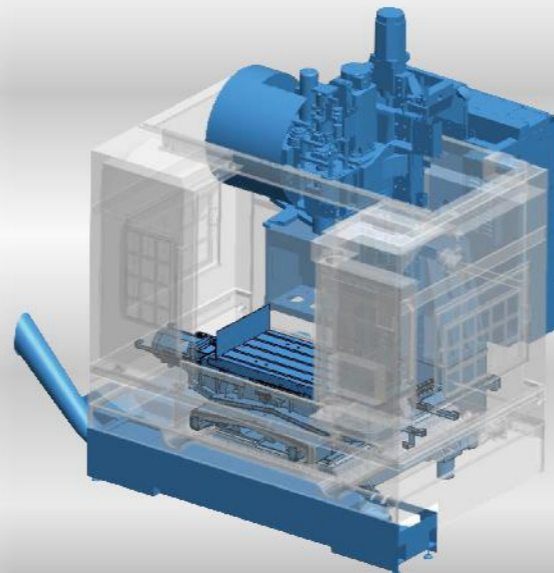

# MACHINE SPECIFICATIONS

ITEM	MODEL	V-22iF/iR	V-30iF/iR	V-32iF/iR	V-32AF/AR
A.T.C	Type	Arm	Arm	Arm	Arm
CAPACITY	Unit				
X axis travel	mm (in)	510(20.1)	800(31.4)	800(31.5)	
Y axis travel	mm (in)	420(16.5)	460(18.1)	520(20.5)	
Z axis travel	mm (in)	510(20.1)	510(20.1)	610(24)	610(24)
Distance from table top to spindle end	mm (in)	100-610(4-24)			100-710(4-28)
Distance from column front to spindle center	mm (in)	460(18.1)	510(20.1)	567(21.5)	
<b>TABLE</b>					
Table size (L x W)	mm (in)	600x400(23.6x15.7)	860x450(33.8x17.7)	890x500(35x19.7)	
Max. table load weight	kg	250	300	500	
T-slot size	mm	18Tx125x3			18Tx100x5
<b>SPINDLE</b>					
Spindle speed	rpm	10000,12000			
Spindle nose (normal size, No.)		7/24 Taper, No.40			
Spindle bearing inner diameter	mm(in)	60(2.36)			70(2.76)
<b>FEED RATE</b>					
Rapid traverse X/Y/Z	m/min(ipm)	48/48/36(1890/1890/1417)			48/48/36(1890/1890/1417)
Max. cutting feed rate	m/min(ipm)	10(394)			
<b>A.T.C.</b>					
Tool storage capacity	pcs	24	24	24	24
Max. tool diameter(with adjacent tools)	mm(in)	80(3.15)	80(3.15)	80(3.15)	80(3.15)
Max. tool length	mm(in)	250(9.8)			250(9.8)
Tool change time T-T/C-C	sec	2.4 / 5			1.8 / 4
<b>MOTORS</b>					
Spindle motor(30 min) FANUC	kw(hp)	11(14.7)			18.5(24.8)
X/Y/Z axis motor	kw(hp)	4/4/4(5.4/5.4/5.4)			4/4/4(5.4/5.4/5.4)
<b>MACHINE SIZE</b>					
Height of machine (H)	mm(in)	2370(93)			2730(107)
Floor space (L x W)	mm(in)	2440x2117(96x83)FRONT/2130x2400(84x94)REAR			2870x2560(113x101)FRONT/2440x3010(96x118.5)REAR
Total machine weight	kg	3455 FRONT/3380 REAR	3700 FRONT/3500 REAR	5400	5450
Power requirement	KVA	30			30
Controller	FANUC	0i-M			

\*AVAILABLE CONTROLLER:SIEMENS/MITSUBISHI/HEIDENHAIN

## Control Panel OPTION



FANUC



SIEMENS



MITSUBISHI



# MACHINE SPECIFICATIONS

ITEM	MODEL	V-42iF/iR		V-42AF/AR	V-52AF/AR
		Type	Arm	Arm	Arm
<b>CAPACITY</b>					
X axis travel	mm (in)	1000(40)		1270(50)	
Y axis travel	mm (in)	520(20.5)		600(23.6)	
Z axis travel	mm (in)	610(24)	610(24)		610(24)
Distance from table top to spindle end	mm (in)	100-710(4-28)		100-710(3.9-27.9)	
Distance from column front to spindle center	mm (in)	567(21.5)		637(25)	
<b>TABLE</b>					
Table size (L x W)	mm (in)	1100x500(43.3x19.7)		1420x580(56x22.8)	
Max. table load weight	kg	500		500(1102)	
T-slot size	mm	18Tx100x5		18Tx100x5	
<b>SPINDLE</b>					
Spindle speed	rpm	10000,12000		10000	
Spindle nose (normal size, No.)		7/24 Taper, No.40		7/24 Taper, NO40	
Spindle bearing inner diameter	mm(in)	60(2.36)	70(2.76)		70(2.75)
<b>FEED RATE</b>					
Rapid traverse X/Y/Z	m/min(ipm)	48/48/36(1890/1890/1417)		48/48/36(1889/1889/1417)	
Max. cutting feed rate	m/min(ipm)	10(394)		10(394)	
<b>A.T.C.</b>					
Tool storage capacity	pcs	24	24		24
Max. tool diameter(with adjacent tools)	mm(in)	80(3.15)	80(3.15)		80(3.15)
Max. tool length	mm(in)	250(9.8)		250(9.8)	
Tool change time T-T/C-C	sec	1.8 / 4		1.8/4	
<b>MOTORS</b>					
Spindle motor(30 min) FANUC	kw(hp)	11(14.7)	18.5(24.8)		18.5(24.8)
X/Y/Z axis motor	kw(hp)	4/4/4(5.4/5.4/5.4)		4(5.4)	
<b>MACHINE SIZE</b>					
Height of machine (H)	mm(in)	2730(107)		2852(112)	
Floor space (L x W)	mm(in)	2870x2560(113x101)FRONT/2440x3010(96x118.5)REAR		3100x3431(122x135)FRONT/2800x3638(110x143)REAR	
Total machine weight	kg	5500	5550		5800
Power requirement	KVA	30	35		35
Controller		FANUC		0i-M	

\*AVAILABLE CONTROLLER:SIEMENS/MITSUBISHI/HEIDENHAIN

## Control Panel OPTION



FANUC



SIEMENS



MITSUBISHI

# MACHINE ACCESSORIES

ITEM	MODEL	V-22iF/iR	V-30iF/iR	V-32iF/iR	V-32AF/AR	V-42iF/iR	V-42AF/AR	V-52AF/AR
RS232		●	●	●	●	●	●	●
Full enclosure guarding		●	●	●	●	●	●	●
Work light		●	●	●	●	●	●	●
Alarm lamp		●	●	●	●	●	●	●
Heat exchanger		●	●	●	●	●	●	●
Rigid tapping		●	●	●	●	●	●	●
Auto counter for workpiece		●	●	●	●	●	●	●
Chip conveyor (auger type) + 2 chip buckets		●/X	●/X	●	●	●	●	●
Remote MPG		●	■	●	●	●	●	●
Spindle speed 8000rpm		●	●	■	■	■	■	●
FANUC control		●	●	●	●	●	●	●
Siemens control		■	■	■	■	■	■	■
Mitsubishi control		■	■	■	■	■	■	■
Spindle speed 10000rpm (steel bearing)		■	●	●	●	●	●	●
Spindle speed 12000rpm (ceramic bearing)		■	■	■	■	■	■	■
Spindle speed 15000rpm (DDS)		▲	▲	▲	X	▲	X	X
Spindle speed 15000rpm (DDS with CTS)		▲	▲	▲	X	▲	X	X
Spindle oil chiller		■	●	●	●	●	●	●
C.T.S. Form A		■	■	■	■	■	■	■
Tool tip air blow system		●	●	■	■	■	■	■
Tool overload detection		■	■	■	■	■	■	■
Tool management		■	■	■	■	■	■	■
Auto tool length measurement TS-27		■	■	■	■	■	■	■
Automatic workpiece measurement OMP-60		■	■	■	■	■	■	■
Chip conveyor outside machine & chip bucket		■	■	■	■	■	■	■
Chip disposal at the front		■	■	■	■	■	■	■
Chip disposal at the rear		■	■	■	■	■	■	■
Oil skimmer		■	■	■	■	■	■	■
Coolant gun		■	■	■	■	■	■	■
Air conditioner		■	■	■	■	■	■	■
4th axis rotary table preparation		■	■	■	■	■	■	■
4th axis rotary table		■	■	■	■	■	■	■
Manual chuck with connecting plate for rotary table		■	■	■	■	■	■	■
Manual tailstock for rotary table		■	■	■	■	■	■	■
Power disk for 4 axis rotary table		■	■	■	■	■	■	■
Through hole drill kit		■	■	■	■	■	■	■
DNC link software		■	■	■	■	■	■	■
Programmable nozzle		■	■	■	■	■	■	■
Programmable air blow		■	■	■	■	■	■	■
CTS preparation		■	■	■	■	■	■	■
Simple Filtrating system & 20bar /25u pump sys.		■	■	■	■	■	■	■
Simple Filtrating system & 40bar /25u pump sys		■	■	■	■	■	■	■
Sub tank		■	■	■	■	■	■	■
Extra coolant tank		■	■	■	■	■	■	■
Spindle annular coolant jet (Arm type ATC)		■	■	■	■	■	■	■
2 Speed gear box		X	X	■	■	■	■	■
Arm type ATC 30 tools		▲	▲	▲	▲	▲	▲	▲
Linear scale		▲	▲	▲	▲	▲	▲	▲
Surrounding coolant system		■	■	■	■	■	■	■
Auto door		▲	▲	▲	▲	▲	▲	▲

● : S.T.D / ■ : O.P.T (DESIGNED) / ▲ : O.P.T (TO BE ADVISED) / X : N/A(NOT AVAILABLE)