

# CENTERS FOR 5-AXIS MACHIN ING

---

**NBH** 630 5X/800 5X/1000 5X

ZUSE **HÜLLER HILLE**  
WERKZEUGMASCHINEN

# ZUSE HÜLLER HILLE NBH 5X – 5-AXIS MACHINING

THE NEW BENCHMARK FOR COMPLETE MACHINING

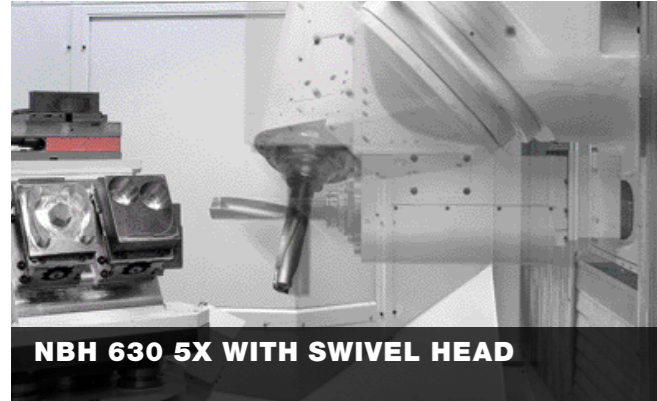

NBH 630 5X WITH SWIVEL HEAD

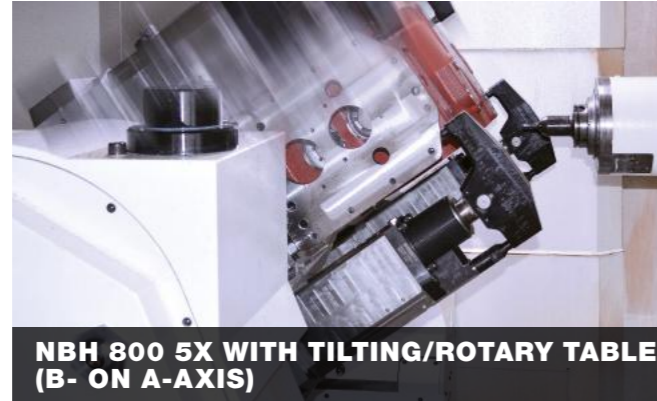

NBH 800 5X WITH TILTING/ROTARY TABLE  
(B- ON A-AXIS)



NBH 1000 5X WITH TILT HEAD

The economic 5-axis machining is found in all industrial areas today. With two different concepts NBH machining centers can also be used for machining of complex workpieces, e.g. for multi-sided machining, bores and surfaces in different solid angles and freeform surfaces.

#### ADVANTAGES:

- Complete machining in one clamping (5-sided machining in one clamping)
- Optimized precision and accuracy, as reclamping is not necessary
- Reduction of unit costs as resetting to other machines is not required
- Reduced need for fixtures
- Use as positioning axis or for simultaneous machining
- Large range of workpieces, materials from light metals to titanium, Inconel and hard metal cutting are possible
- High tool capacity and convenient set-up thanks to one-of-a-kind tool magazine technology

#### FIELDS OF APPLICATION OF THE NBH 5X

- 5-sided machining of cubic workpieces in mechanical engineering
- Complete machining of precision parts with low shape and position tolerances for engine and transmission automotive and non-automotive applications
- 5-sided machining with long and heavy tools as well as bridge tools with large diameters when machining gearbox housings
- More efficient production due to 5-sided machining with a reduced number of clampings and higher machining accuracy owing to lower clamping errors in fittings and pump industry
- High surface quality of workpieces for die and tool production
- Integral components made of aluminium (high performance) and high-strength connection parts made of titanium or Inconel (high torques) with material removal volumes of up to 90% in aerospace industry

The proven rack-type cassette magazine for enhanced machine utilization by changing 50 tools during machining by means of a cassette carriage in just a few minutes can also be used for 5-sided machining



#### YOUR ADVANTAGES AT A GLANCE

- Machine concepts tailored towards optimized part costs
- Configure the NBH 5-axis machine in line with your specific requirements
- Robust machine design ensures reliable, long-lasting precision in production
- Excellent accessibility to all modules provides easy set-up, operation and service
- High technology competence
- Long-term security for your investment
- Easy operation and service
- Easy integration in flexible pallet storage systems and automation systems





## 5-AXIS MACHINING WITH SWIVEL HEAD

THE RE-DEVELOPED NBH 630 5X IS CHARACTERIZED BY ECONOMIC 5-AXIS MACHINING. THANKS TO A MIX OF COUNTLESS INNOVATIONS AND THE POSITIVE CHARACTERISTICS OF THE PREVIOUS HÜLLER HILLE NBH SERIES, THE NEW MACHINE CONCEPT IS DESIGNED BOTH FOR SIMULTANEOUS PRECISION MACHINING AND HEAVY-DUTY CUTTING.

**WITH THE NEWLY AVAILABLE 5-AXIS MACHINES, THE WIDE RANGE OF ADVANTAGES OF THE NBH SERIES IS BEING ENHANCED BY THE FOLLOWING BENEFITS:**

- Reduction of unit costs due to complete 5-sided machining in one clamping
- Extraordinary chip removal rate when roughing and high surface quality when finishing thanks to extremely high retention forces in the rotary axes
- Extremely high dimensional stability of the workpiece due to thermally stable machine as standard configuration
- Large range of workpieces, materials from light metals to titanium, Inconel and hard metal cutting are possible
- High tool capacity and convenient set-up thanks to one-of-a-kind tool magazine technology
- Perfect ergonomic accessibility during operation and maintenance

**YOUR ADVANTAGES AT A GLANCE:**

- Universal machining center with swivel head, swivel axis arranged in 45°
- High holding torque during simultaneous machining thanks to innovative electromechanical gear technology in swivel head and NC rotary table
- Standard accuracy package for minimizing temperature affects due to cooled servo motors, ball screw nuts and gears ensure maintained precision and process reliability
- Optimized machine bed, chip removal to the rear
- New, dual-walled, closed and extremely stable machine base
- Workpiece set-up during machining cycle via 180° pallet changer
- Optional direct loading of the machine without pallet changer, optimal use as system machine in powertrain segment
- Modular tool magazines available for a great variety of production requirements, ranging from 60 to 300 tool locations

# NBH 630 5X

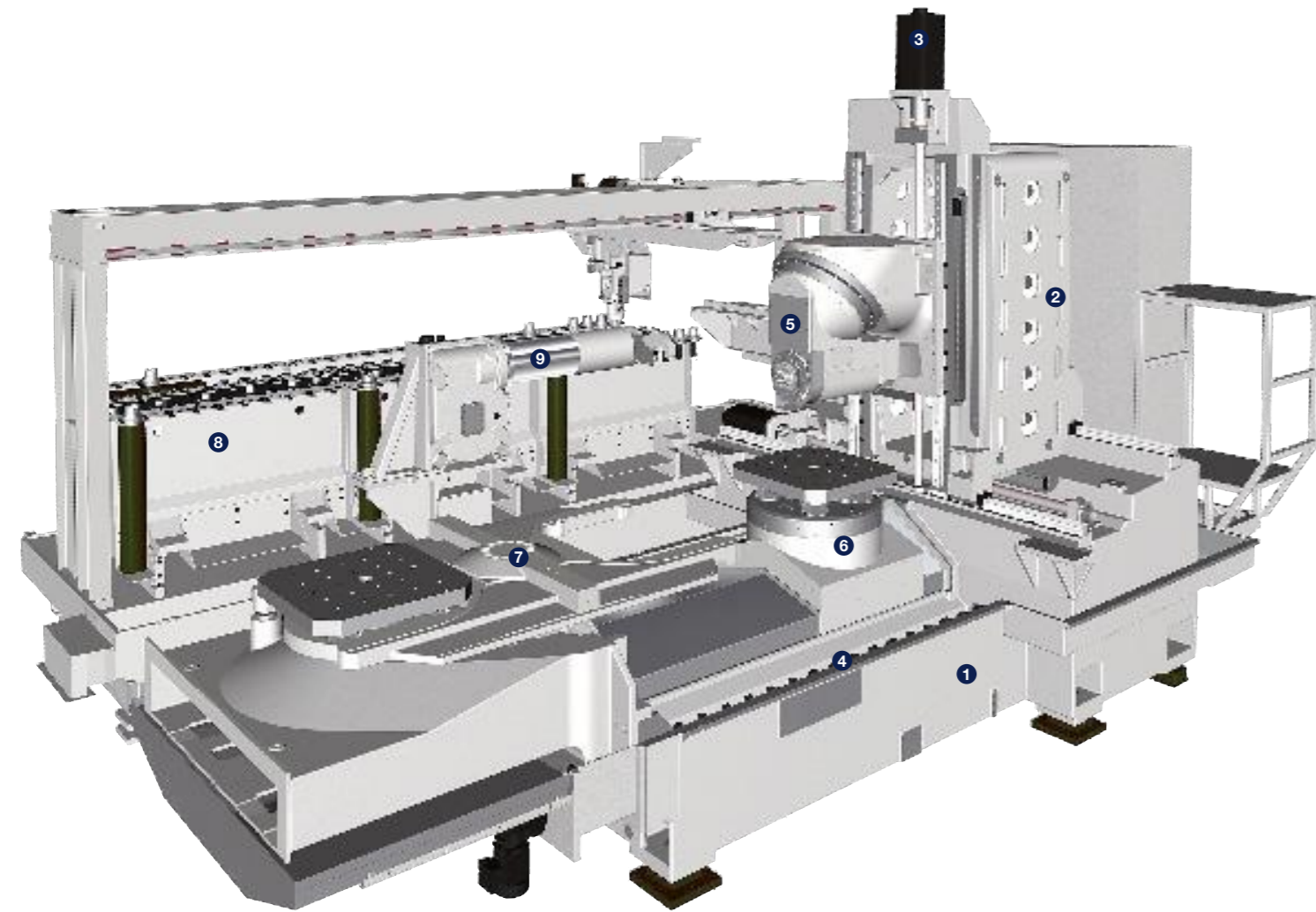

Tool cassette magazine with 3 cassettes available as an option

- ❶ Single cast, self-supporting machine bed
- ❷ Dual-wall cast machine base
- ❸ Digital drives, water-cooled servo motors
- ❹ Safe and easy chip removal towards rear of machine
- ❺ Swivel head with working spindle  
(Further information page 7)
- ❻ NC rotary table with gear
  - High holding torque during simultaneous machining
  - Highly precise positioning
  - High dynamics with rapid traverse up to 40 rpm
- ❼ Pallet changer
  - Fast 180° swivel changer, changing time approx. 13 s
  - Set-up during machining cycle
  - Rotary set-up station
- ❽ Modular tool magazine
  - Disc-type magazine (60 tool locations)
  - Disc-type magazine (120 tool locations)
  - Hüller Hille cassette magazine (up to 300 tool locations)
  - Standard patented tool cone cleaning using metal blades integrated in the tool handling device
- ❾ Tool changer
  - Fast electromechanical tool changer with automatic mechanical locking when swivelling, Swivel time vertical horizontal approx. 1.2 s, Chip-to-chip time (VDI 2852) approx. 4.8 s

#### Automation

- Uncomplicated connection to flexible pallet storage and automation systems
- Fully compatible with already supplied systems thanks to uniform interface

#### Modern, powerful CNC control

- Siemens Sinumerik 840D sl
- 19 inch monitor, ergonomically adjustable control panel

# TECHNOLOGICAL MACHINE HIGHLIGHTS FOR EFFECTIVE 5-AXIS MACHINING

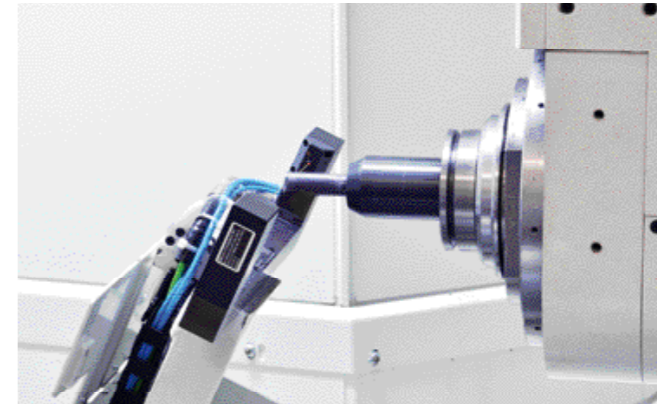
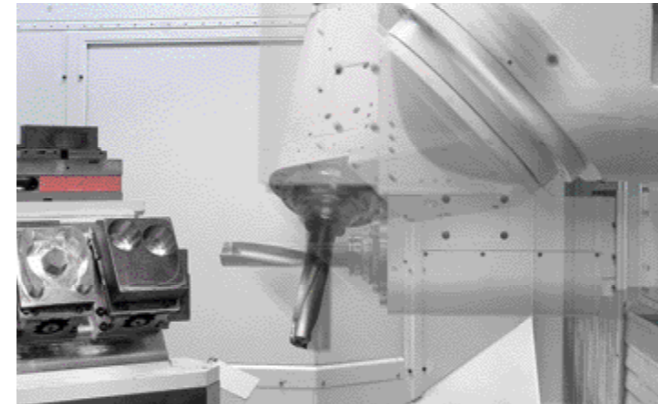
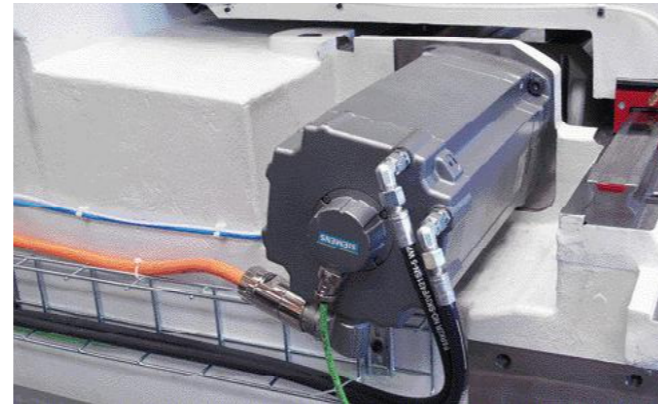
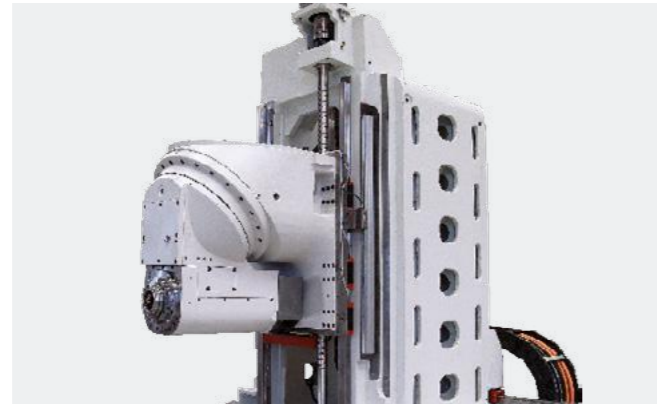
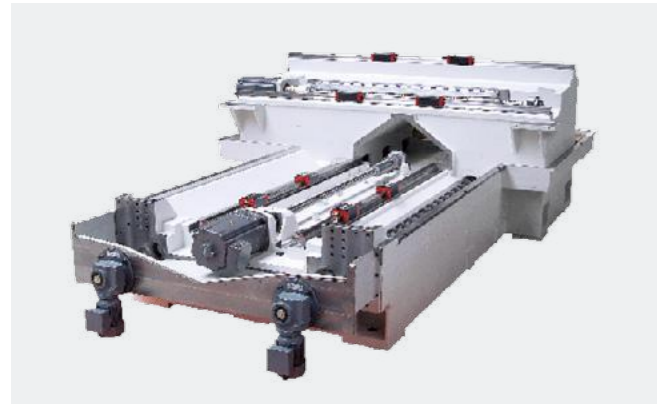

## SINGLE, SELF-SUPPORTING MACHINE BED

- Heavily ribbed, one-piece casting with high damping characteristics
- Calculated with FEM and examined with modal analysis
- Free chip fall
- Optimized chip disposal via two chip grooves integrated in machine bed
- Chip removal to the rear, chip conveyor behind machine saves space
- Optimal impermeability and accessibility due to cast-on console for switch cabinet and additional units

## DUAL-WALL CLOSED MACHINE BASE

- Extensively ribbed, dual-wall cast machine base
- Calculated with FEM and examined with modal analysis
- Thermosymmetric structure

## ROBUST GUIDANCE SYSTEM

- Profile rail guides with absolute, direct position measuring system via glass scale
- Height-offset X-guide for optimal absorption of machining forces
- 6 recirculating roller units in Y-guide
- High rigidity and stick-slip free axis movement

## STANDARD ACCURACY PACKAGE FOR TEMPERATURE COMPENSATION

- Cooled servo-motors and ball screw nuts
- Cooled gears
- Spindle displacement sensor
- External coolant temperature control [option]
- Efficient compressor cooling aggregate

## TECHNOLOGICAL FEATURES OF THE SWIVEL HEAD

- Infinitely variable swivel range from 0° up to -225°, horizontal = 0°, vertical = -180°
- Complete swivel range throughout the entire travel range in the X-axis (partly limited for NBH 800 5X)
- High holding torque during simultaneous machining thanks to innovative electromechanical gear technology
- Cooled drives and gears
- Cast swivel head housing (GGG 60)
- Spindle displacement sensor
- Optimized swivel head design, interference contours on spindle housing minimized

## PROCESS MONITORING [OPTION]

- In-process tool breakage monitoring in the tool magazine area
- Laser tool measurement in working area
  - Extendable laser unit protected in closed housing
  - Dynamic tool measurement horizontal and vertical at machining speed
  - Comprehensive measuring cycles: e.g. tool length, radius, shape inspection, single cutting edge control, run-out, wear, drill breakage, measuring, checking, correcting
- Workpiece measurement
  - Measuring probe with infrared or radio transmission of the measured values for measuring of workpieces and/or clamping fixtures within working area

## MODERN ERGONOMICS AND PERFECT ACCESSIBILITY

- Excellent accessibility to XXL workspace thanks to wide two-part doors
- Crane loading from above at the set-up station and in the working area due to optimal operation door/machine roof construction
- Two-piece control console which can be perfectly adjusted to the operator

**NBH** 800 5X

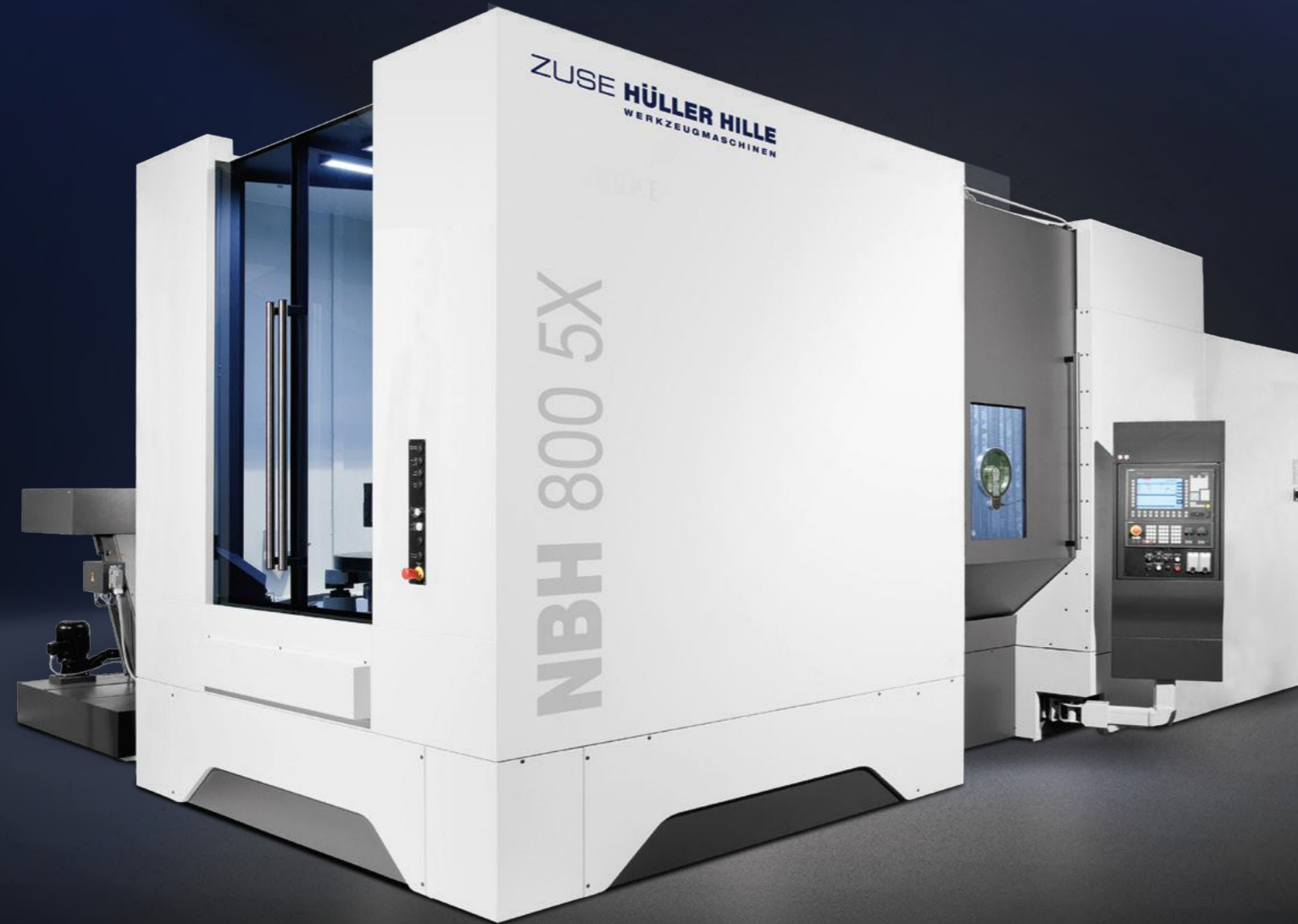

# 5-AXIS MACHINING WITH SWIVEL HEAD

**THE SWIVEL HEAD INSTALLED IN NBH 630 5X IS ALSO USED IN NBH 800 FOR SIMULTANEOUS 5-AXIS MACHINING. THANKS TO THE HIGHLIGHTS OF THIS SWIVEL HEAD AND THE TECHNOLOGICAL ADVANTAGES OF THE 4-AXIS NBH 800 THE NBH 800 5X WITH PALLET SIZE UP TO 1000 X 1000 MM IS A REAL UNIVERSAL MACHINING CENTER:**

- Reduction of unit costs due to complete 5-sided machining in one clamping
- Extraordinary chip removal rate when roughing and high surface quality when finishing thanks to extremely high retention forces in the rotary axes
- Large range of workpieces, materials from light metals to titanium, Inconel and hard metal cutting are possible
- High tool capacity and convenient set-up thanks to one-of-a-kind tool magazine technology
- Perfect ergonomic accessibility during operation and maintenance

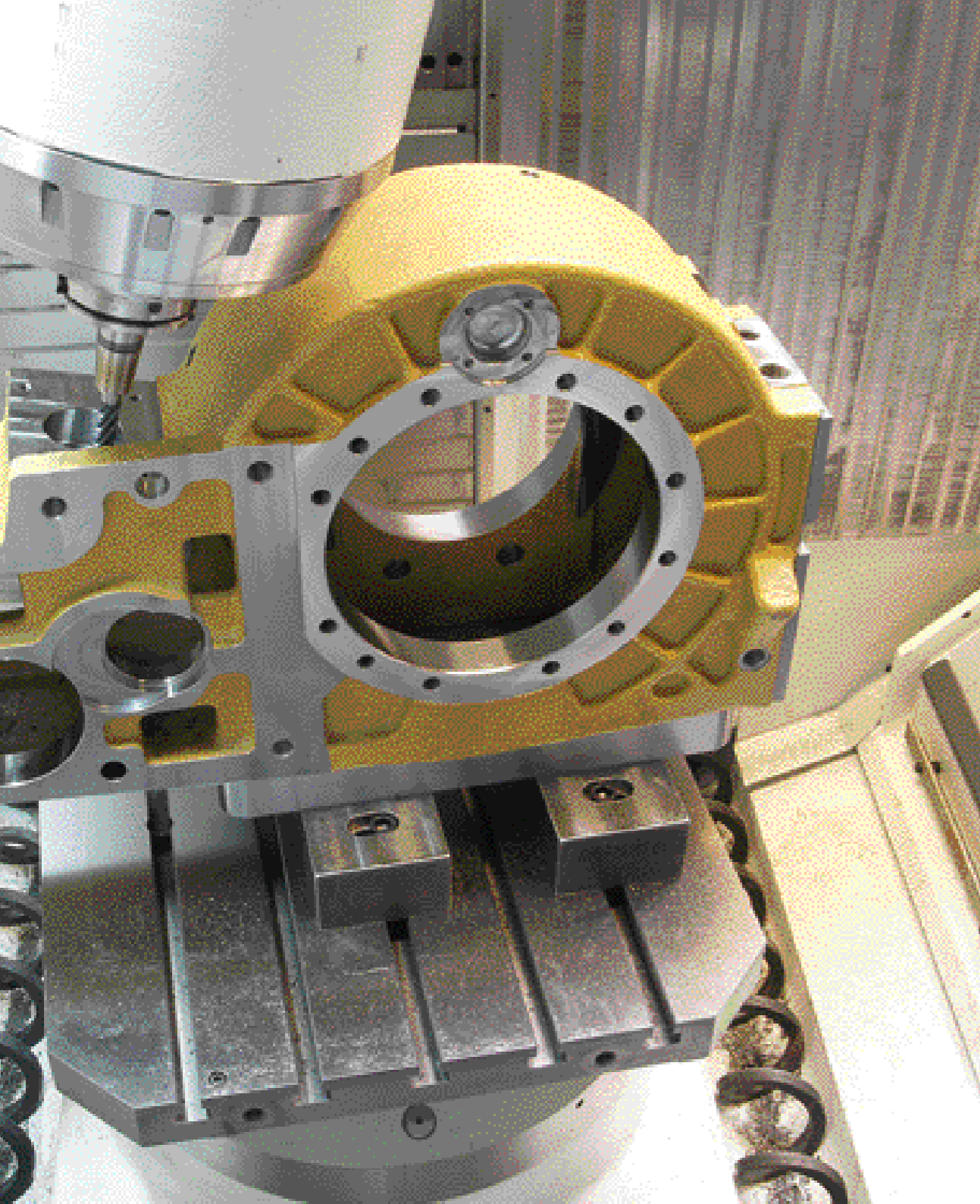

# NBH 800 5X

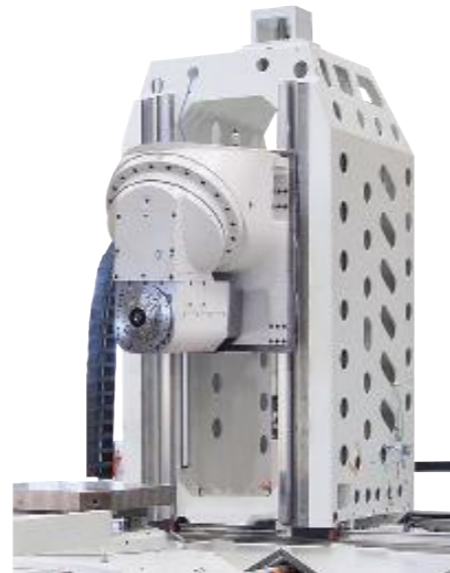

Closed, double-walled and optimally ribbed machine column



Machine bed with gantry drive in Z-axis and 4 integrated chip grooves for optimal chip removal

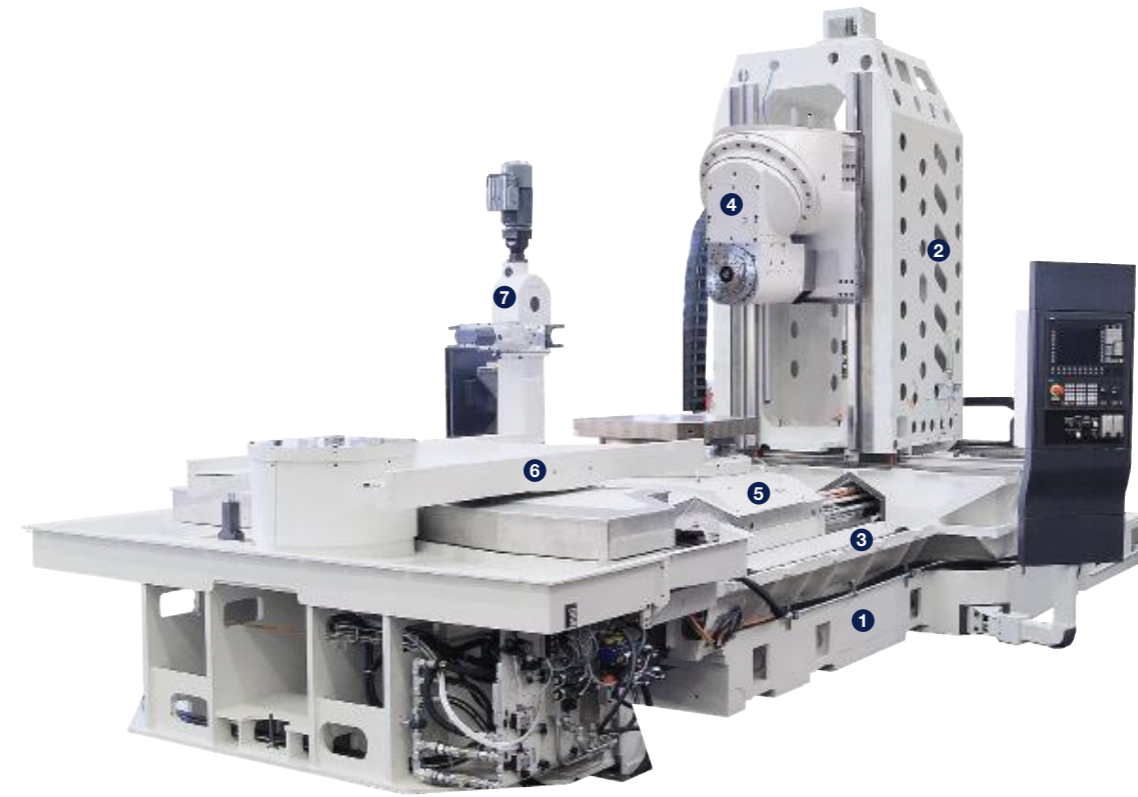

- ❶ Single cast machine bed
- ❷ Machine column, double-walled and extensively ribbed casting
- ❸ Safe and easy chip removal towards rear of machine [option]
- ❹ Swivel head with working spindle (Further information page 7)
- ❺ Torque table, direct driven rotary axis
- ❻ Pallet changer
  - Fast 180° swivel changer, changing time approx. 20 s
  - Set-up during machining cycle
  - Rotary set-up station
- ❼ Tool changer
  - Fast electromechanical tool changer with automatic mechanical locking when swivelling, Swivel time vertical horizontal approx. 1.2 s, Chip-to-chip time (VDI 2852) approx. 5.9 s

#### Modular tool magazine

- Disc-type magazine (60 tool locations)
- Disc-type magazine (120 tool locations)
- Hüller Hille cassette magazine (up to 300 tool locations)
- Standard patented tool cone cleaning using metal blades integrated in the tool handling device

#### Automation

- Uncomplicated connection to flexible pallet storage and automation systems
- Fully compatible with already supplied systems thanks to uniform interface

#### Modern, top-performing CNC control

- Siemens Sinumerik 840D sl

#### YOUR ADVANTAGES AT A GLANCE:

- Universal machining center with swivel head, swivel axis arranged in 45°
- High holding torque during simultaneous machining thanks to innovative electromechanical gear technology in swivel head and NC rotary table
- Optimized machine bed, chip removal to the rear
- Dual-walled, closed and extremely stable machine base
- Workpiece set-up during machining cycle via 180° pallet changer
- Optional direct loading of the machine without pallet changer, optimal use as system machine in powertrain segment
- Modular tool magazines available for a great variety of production requirements, ranging from 60 to 300 tool locations

# TECHNICAL DATA

**NBH 630 5X/800 5X  
WITH SWIVEL HEAD**

Horizontal machining center	type	NBH 630 5X	NBH 800 5X
<b>Working range</b>			
Travel X-axis	mm	1000	1400
Travel Y-axis	mm	850 [1050]	1100 [1400]
Travel Z-axis	mm	1150	1800
Swing circle diameter (limited)	mm	900 (1150)	1300 (1600)
Fixture height	mm	1350	1500
<b>Position measuring system, glass scales</b>			
Positioning error A (DIN ISO 230-2)	mm	0,006	0,007
<b>Pallet / rotary table</b>			
Pallet clamping surface DIN 55201	mm	630 x 630 [800 x 800]	800 x 800 [1000 x 1000]
Max. pallet load	kg	1500	2000
NC rotary table, smallest fraction	deg	0,001	0,001
Rotary speed B-axis	rpm	40	25
Pallet changing time as per VDI 2852	approx. s	13	20
<b>Swivel head spindle</b>			
Swivel range, horizontal = 0°	deg	0 up to -225	0 up to -225
Positioning accuracy (DIN ISO 230-2)	arc s	10	10
Rapid traverse swivel axis	rpm	40	40
Speed range max.	rpm	10 000	10 000
Spindle power 100%/40% duty	kW	30/38	30/38
Torque 100%/40% duty	Nm	286/378	286/378
Tool taper	type	HSK 100	HSK 100
Internal coolant supply spindle [option]	bar	40 [70]	40 [70]
<b>Feed / rapid traverse</b>			
Feed force X-, Y-, Z-axis	approx. kN	15/15/20	20/10/20
Feed range X-, Y-, Z-axis	mm/min	0 – 60 000	0 – 40 000
Rapid traverse X-, Y-, Z-axis	m/min	60/60/60	40/40/40
Acceleration X-, Y-, Z-axis	m/s <sup>2</sup>	7/7/7	4/4/4
<b>Tool disc magazine, locations</b>			
Tool diameter max.	mm	125	125
... adjacent tool locations empty	mm	325	325
Tool length max.	mm	600	600
Tool weight max.	kg	40	40
Tilting moment max.	Nm	50	50
Chip-to-chip time, tools up to 6 kg (VDI 2852)	approx. s	4,8	5,9
<b>(Tool cassette magazine)</b>			
Tool loading/unloading station [drawer]	number	1 [4]	1 [4]
Tool cassette	number	[3] [4] [6]	[3] [4] [6]
Tool locations	number	[150] [200] [300]	[150] [200] [300]
Tool diameter max.	mm	125	125
... adjacent tool locations empty	mm	325 [400] <sup>1)</sup>	325 [400] <sup>1)</sup>
Tool length max.	mm	800 <sup>2)</sup>	800 <sup>2)</sup>
Tool weight max.	kg	40 [50]	40 [50]
Tilting moment max.	Nm	50 [100]	50 [100]
Chip-to-chip time, tools up to 6 kg (VDI 2852)	approx. s	5,4	5,9
<b>Machine</b>			
Control, Siemens Sinumerik	type	840D sl	840D sl
Machine weight	approx. kg	25 000	42 000

[...] = option,  
1) = only in special cassette,  
2) = possible collision with the maximum interference circle diameter of the fixture

Subject to change without notice

## MAIN DIMENSIONS AND WORKING AREA

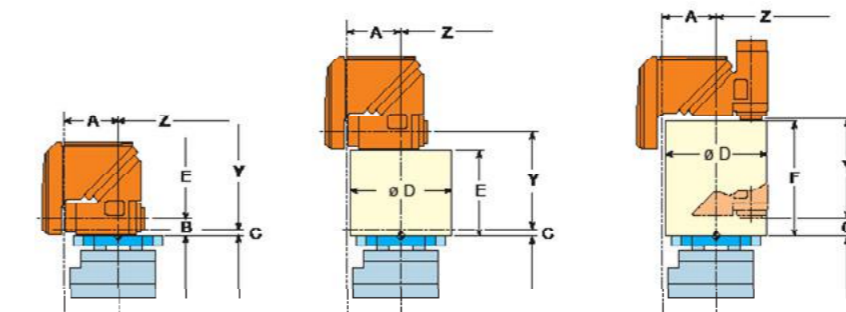
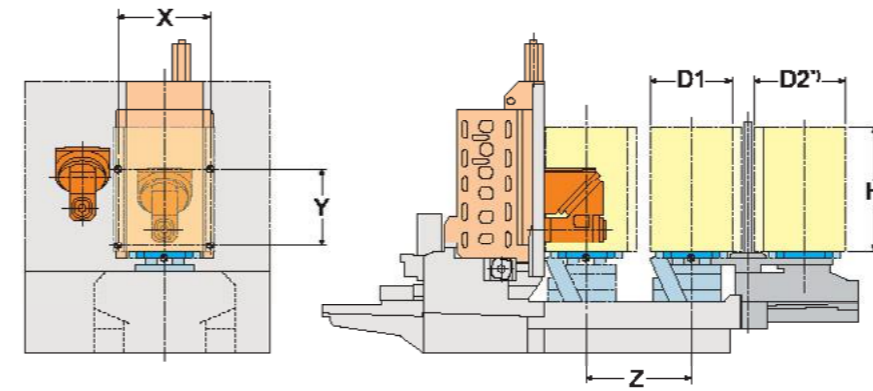
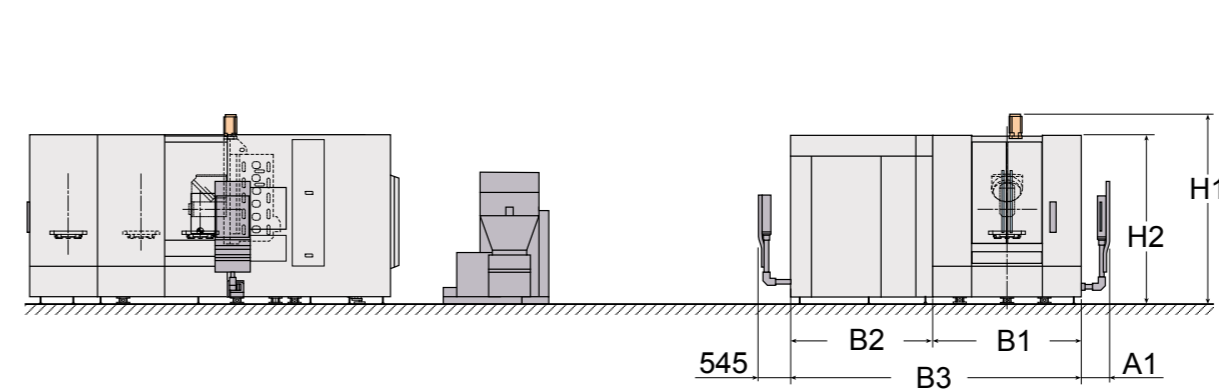

Subject to change without notice

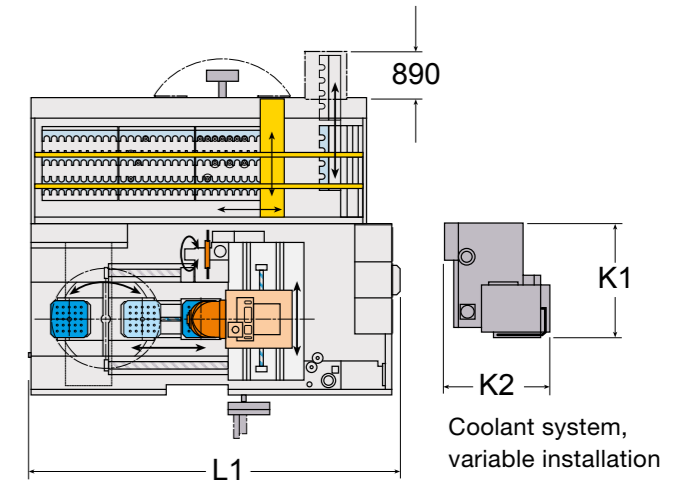

Machine	type	NBH 630 5X	NBH 800 5X
L1	approx. mm	5980	8665
B1	approx. mm	2806	3100
B2	approx. mm	2454	2454
B3	approx. mm	5260	5554
H1	approx. mm	3250	4171
H2	approx. mm	3550	3590
A1	approx. mm	1232	677
K1	approx. mm	2000	2000
K2	approx. mm	1700	1800
X	mm	1000	1400
Y	mm	850 [1050]	1400
Z	mm	1150	1800
D1	mm	ø 900	ø 1300
D2 <sup>1)</sup>	mm	ø 1150	ø 1600
H	mm	1350	1500
X	mm	1000	1400
Y	mm	850 [1050]	1100 [1400]
Z	mm	1150	1800
A	mm	450	637
B	mm	155	145
C	mm	60	10
D	mm	ø 900	ø 1300
E	mm	755 [955]	965 [1265]
F	mm	995 [1195]	1195 [1495]
G	mm	160	110

<sup>1)</sup> = swivel range limited



# NBH 800 5X/1000 5X

The concept of the NBH 800 5X / NBH 1000 5X with a stable tilting/rotary table (B- on A-axis) provides the rigid and high accuracy column and spindle arrangement for X- and Y-axis tool movement whilst the workpiece is moved by axes Z, A and B. This convincing solution (jig boring mill axis arrangement) has proven to be very robust and thermostable ensuring max. stability and highest accuracy.

Together with the proven components such as all NBH motor and gear spindles and the various Hüller Hille tool magazines the machine can be optimally configured to meet the requested production quality. The unique Hüller Hille cassette magazine can, for example, accommodate up to 800 mm long and up to 50 kg heavy special tools. The machine is designed for direct loading on the table with clamping fixture or for loading with the proven 180° swivel-typepallet changer.

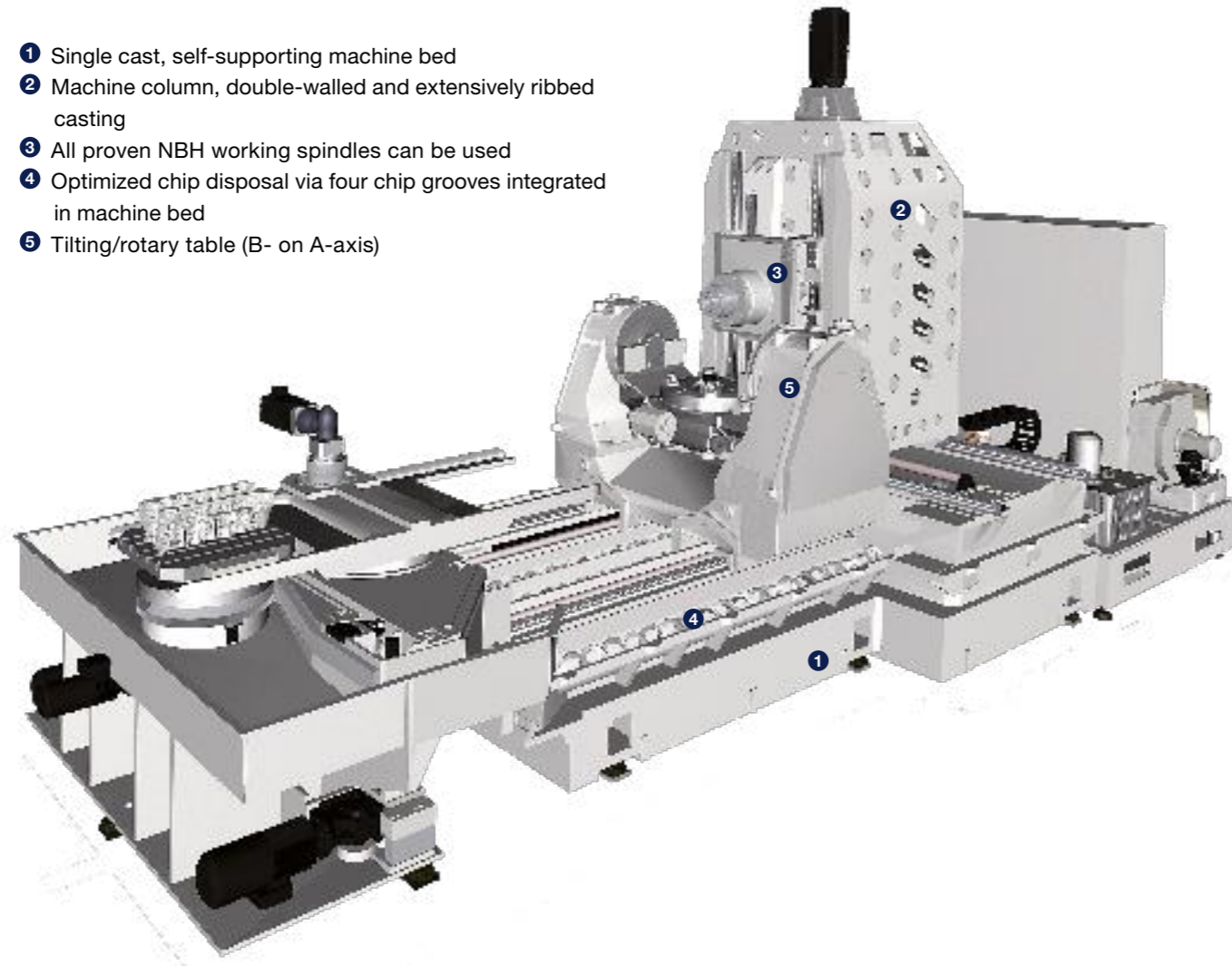

- 1 Single cast, self-supporting machine bed
- 2 Machine column, double-walled and extensively ribbed casting
- 3 All proven NBH working spindles can be used
- 4 Optimized chip disposal via four chip grooves integrated in machine bed
- 5 Tilting/rotary table (B- on A-axis)

# 5-AXIS MACHINING WITH TILTING/ROTARY TABLE



Direct loading of fixture on tilting/rotary table by means of 6-axis robot

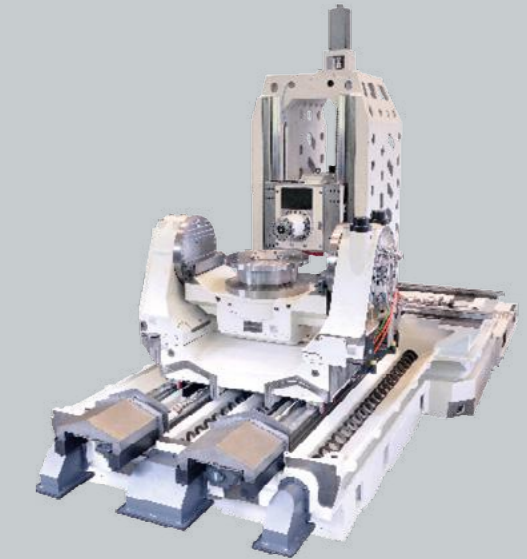
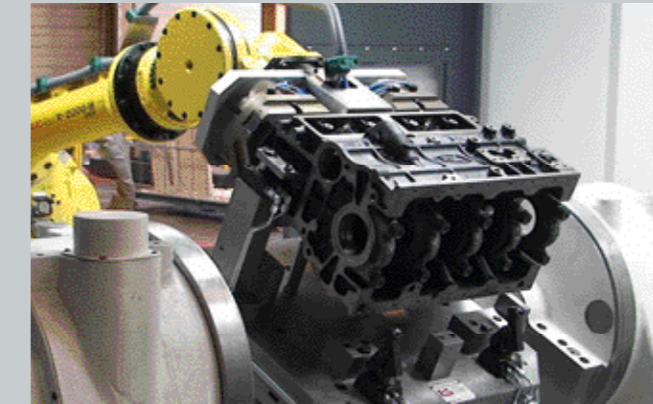

## TILTING/ROTARY TABLE FOR 5-AXIS MACHINING

The tilting/rotary table (B- on A-axis) is particularly suitable for heavy machining of complex workpieces from 5 sides, with bores and areas in different solid angles and freeform surfaces.

- Complete machining in one clamping (5-sided machining without re-clamping)
- Use as positioning axis or for simultaneous machining
- High swivelling moment and feed rate in A-axis through backlash-free double worm gear drive
- All proven NBH working spindles with high torque and performance for highest accuracy requirements can be used



Direct loading of fixture on tilting/rotary table by means of 6-axis robot

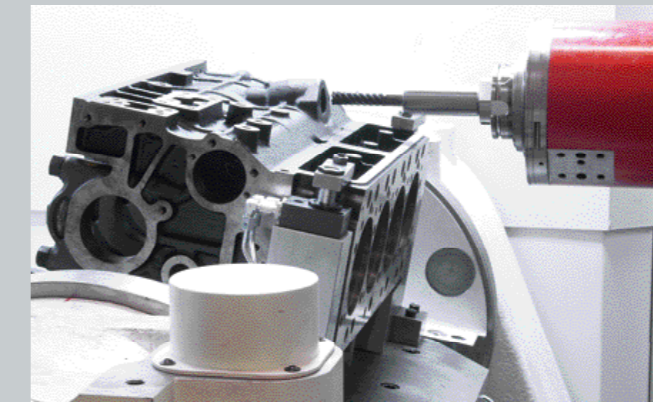

Complete machining of complex workpieces in one clamping, as no re-setting is necessary even at different solid angles

# TECHNICAL DATA

## NBH 800 5X/ 1000 5X WITH TILTING/ROTARY TABLE

Horizontal machining center	type	NBH 800 5X	NBH 1000 5X
<b>Working range</b>			
Travel X-axis	mm	1400	1800
Travel Y-axis	mm	1100 [1400]	1400
Travel Z-axis	mm	1400	1800
Swing circle diameter	mm	1200	1600
Fixture height	mm	1100 [1400]	1400
<b>Position measuring system, glass scales</b>			
Positioning error A (DIN ISO 230-2)	mm	0,007	0,007
<b>Tilting/rotary table / pallet</b>			
Pallet clamping surface DIN 55201	mm	800 x 800	1000 x 1000
Max. pallet load / table load	kg	1200/1500	2500
Swivelling range A-axis	deg	-30 up to +120	-30 up to +120
Rotary speed A-axis	rpm	15	15
Swivelling range B-axis	deg	360	360
NC rotary table, smallest fraction	deg	0,001	0,001
Rotary speed B-axis	rpm	40	25 (40) <sup>1)</sup>
Pallet changing time as per VDI 2852	approx. s	40	45
<b>Motor spindle</b>			
Speed range max.	rpm		8000 [12 000]
Spindle power 100%/40% duty	kW		54/66 54/66
Torque 100%/40% duty	Nm		300/370 300/370
<b>Geared spindle</b>			
Speed range max.	rpm	[6000 o. 10 000]	[5000] [5000]
Spindle power 100%/40% duty	kW	37/46	37/46 60/80
Torque 100%/40% duty	Nm	908/1130	908/1130 2200/2600
<b>Feed / rapid traverse</b>			
Feed force X-, Y-, Z-axis	approx. kN	20/10/20	20/10/20
Feed range X-, Y-, Z-axis	mm/min	0 – 60 000 [Y = 0 – 40 000] <sup>2)</sup>	0 – 40 000
Rapid traverse X-, Y-, Z-axis	m/min	60/60 [40] <sup>2)/60</sup>	40/40/40
Acceleration X-, Y-, Z-axis	m/s <sup>2</sup>	6/6 [4] <sup>2)/6</sup>	4/4/4
<b>Tool disc magazine, locations</b>			
Tool diameter max.	mm	125	125
... adjacent tool locations empty	mm	325	325
Tool length max.	mm	600	600
Tool weight max.	kg	40	40
Tilting moment max.	Nm	50	50
Chip-to-chip time, tools up to 6 kg (VDI 2852)	approx. s	4,0	6,0
<b>(Tool cassette magazine)</b>			
Tool loading/unloading station [drawer]	number	1 [4]	1 [4]
Tool cassette	number	[3] [4] [6]	[3] [4] [6]
Tool locations	number	[150] [200] [300]	[150] [200] [300]
Tool diameter max.	mm	125	125
... adjacent tool locations empty	mm	325 [400] <sup>3)</sup>	325 [400] <sup>3)</sup>
Tool length max.	mm	800 <sup>4)</sup>	800 <sup>4)</sup>
Tool weight max.	kg	40 [50]	40 [50]
Tilting moment max.	Nm	50 [100]	50 [100]
Chip-to-chip time, tools up to 6 kg (VDI 2852)	approx. s	4,0	5,7
<b>Machine</b>			
Control, Siemens Sinumerik	type	840D sl	840D sl
Machine weight	approx. kg	42 000	37 000

[...] = option,

1) = at reduced load as per NBH 800 5X

2) = when travel Y-axis is 1400 mm

3) = only in special cassette

4) = possible collision with the maximum interference circle diameter of the fixture

Subject to change without notice

## MAIN DIMENSIONS AND WORKING AREA

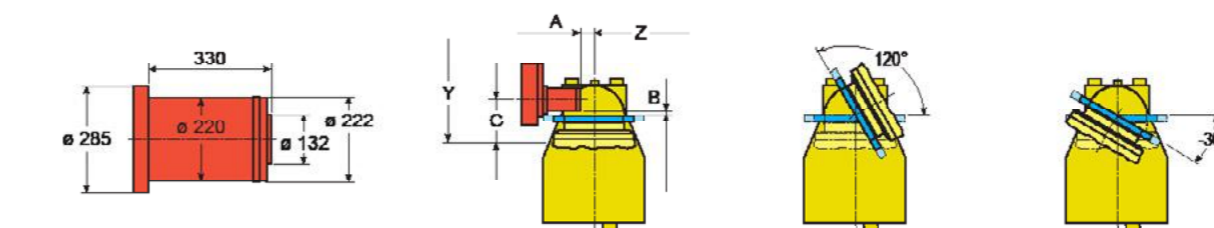
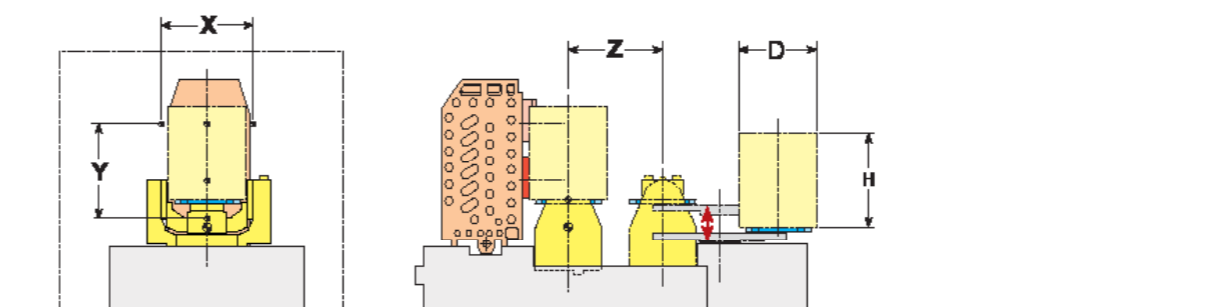
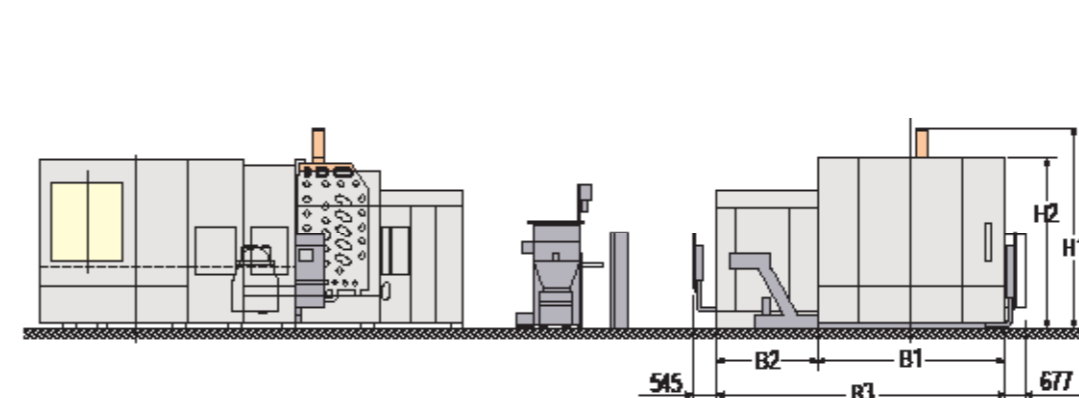

Subject to change without notice

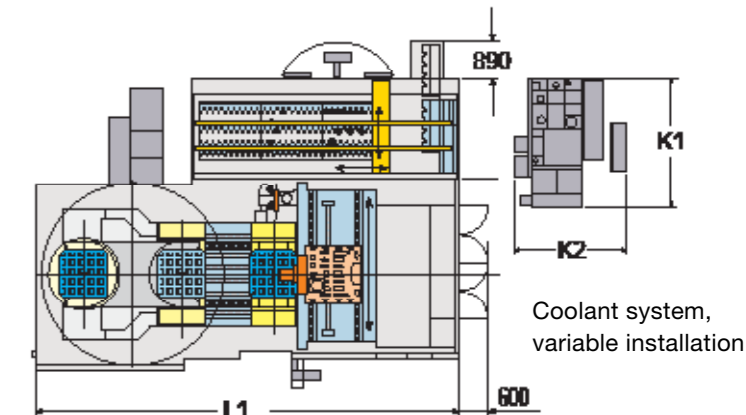

Coolant system,  
variable installation

Machine	type	NBH 800 5X	NBH 1000 5X
L1	approx. mm	7965	9090
B1	approx. mm	3103	3900
B2	approx. mm	2372	2175
B3	approx. mm	5475	6075
H1	approx. mm	3610	3590
H2	approx. mm	4260	4175
K1	approx. mm	2000	2000
K2	approx. mm	1800	1800
X	mm	1400	1800
Y	mm	1100 [1400]	1400
Z	mm	1400	1800
D	mm	ø 1200	ø 1600
H	mm	1100 [1400]	1400
Y	mm	1100 [1400]	1400
Z	mm	1400	1800
A	mm	112,5	237,5
B	mm	24	24
C	mm	400	400

**NBH** 1000 5X

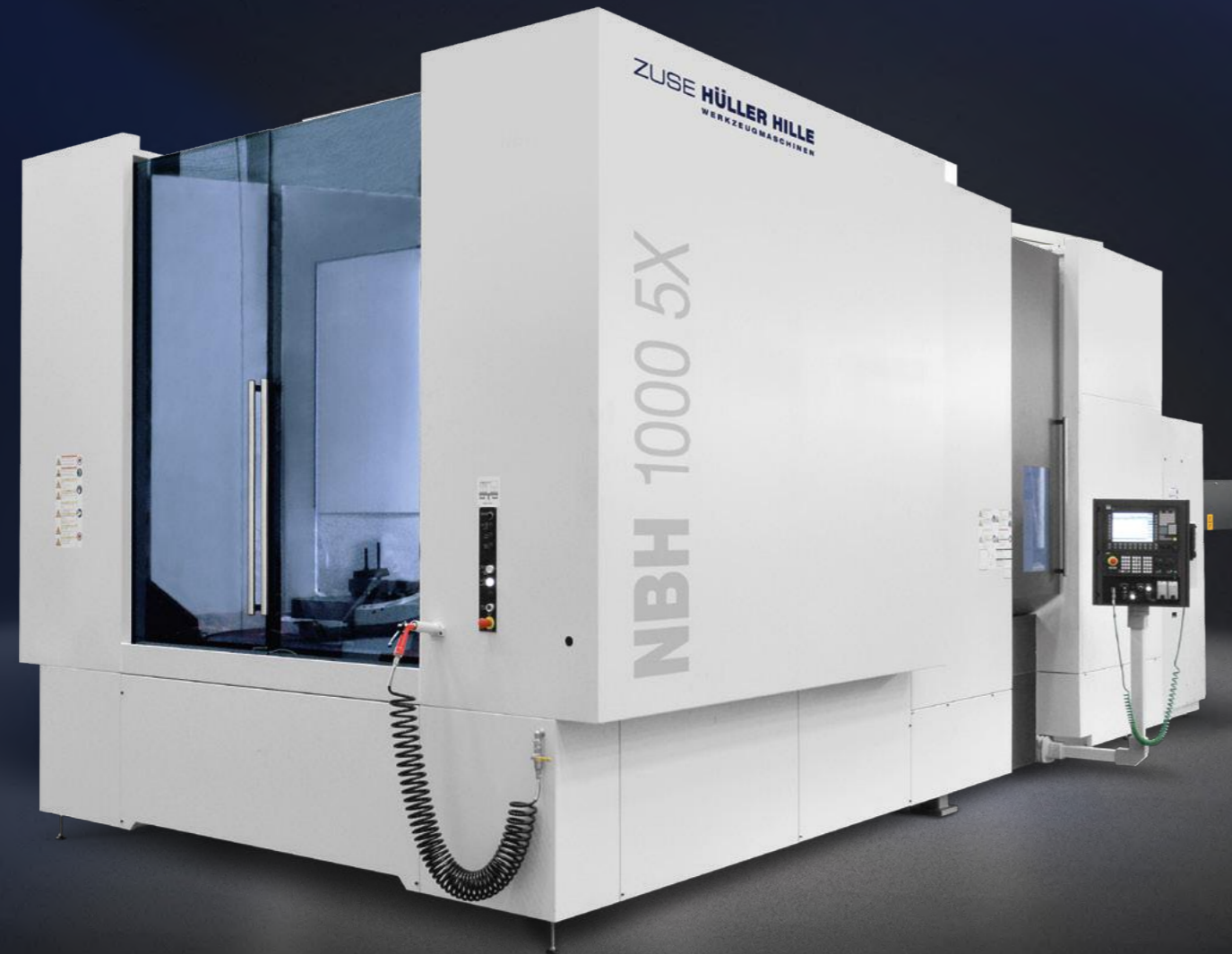

# 5-AXIS MACHINING WITH TILT HEAD

The NBH 1000 5X for 5-axis machining can be equipped alternatively with a tilt head (A-axis) with powerful geared spindle (1390 NM). Due to the stiff structure and the high performance a wide range of applications is covered. Workpiece materials from plastics (Composite), aluminium, steel to titanium, Inconel and hard metal cutting are possible. The swivel range of the A-axis is from  $-120^{\circ}$  to  $+60^{\circ}$ .

Here again, the machine is based on the 4-axis NBH 1000 with all technological advantages. In addition, the column of the machine is equipped at the rear with a profile guideway to support the tilt head.

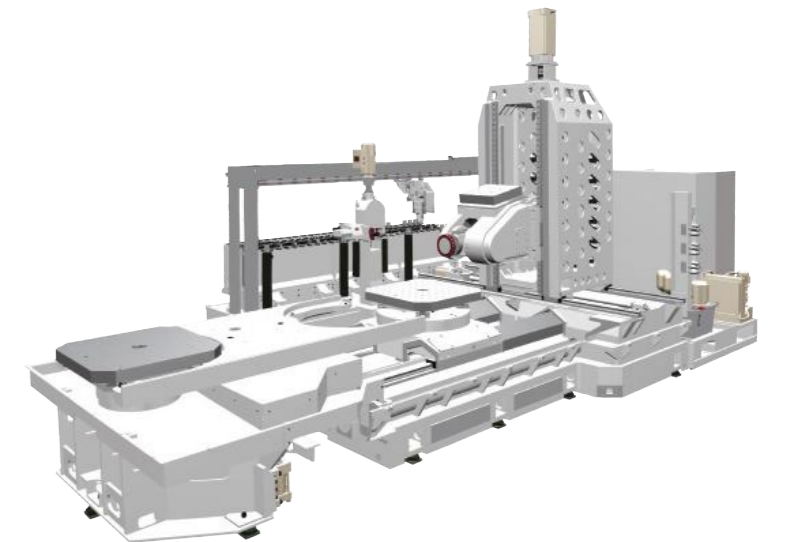

# NBH 1000 5X

Closed, double-walled and optimally ribbed machine column with additional profile guideway at rear to support the tilt head.



Machine bed with gantry drive in Z-axis and 4 integrated chip grooves for optimal chip removal.



Milling machining with tilt head



Drilling machining with tilt head

# TECHNICAL DATA

## NBH 1000 5X WITH TILT HEAD

Horizontal machining center	type	NBH 1000 5X
<b>Working range</b>		
Travel X-axis	mm	1800
Travel Y-axis	mm	1400
Travel Z-axis	mm	1800
Swing circle diameter (limited)	mm	1700 (2000)
Fixture height	mm	1700
<b>Position measuring system, glass scales</b>		
Positioning error A (DIN ISO 230-2)	mm	0,007
<b>Pallet / rotary table</b>		
Pallet clamping surface DIN 55201	mm	1000 x 1000 [1000 x 1250]
Max. pallet, table load	kg	3000
NC rotary table, smallest fraction	deg	0,001
Rotary speed B-axis	rpm	25
Pallet changing time as per VDI 2852	approx. s	25
<b>G geared spindle (tilt head)</b>		
Swivelling range A-axis	deg	+60 up to -120
Positioning accuracy (DIN ISO 230-2)	arc s	10
Rotary speed A-axis	rpm	10
Speed range max.	rpm	6000
Spindle power 100%/40% duty	kW	37 / 46
Torque 100%/40% duty	Nm	1150 / 1390
Tool taper	type	HSK 100 / SK 50
<b>Feed / rapid traverse</b>		
Feed force X-, Y-, Z-axis	approx. kN	20 / 10 / 20
Feed range X-, Y-, Z-axis	mm/min	0 – 40 000
Rapid traverse X-, Y-, Z-axis	m/min	40 / 40 / 40
Acceleration X-, Y-, Z-axis	m/s <sup>2</sup>	4 / 4 / 4
<b>Tool disc magazine, locations</b>		
Tool diameter max.	mm	125
... adjacent tool locations empty	mm	325
Tool length max.	mm	600
Tool weight max.	kg	40
Tilting moment max.	Nm	50
Chip-to-chip time, tools up to 6 kg (VDI 2852)	approx. s	6,8
<b>(Tool cassette magazine)</b>		
Tool loading/unloading station [drawer]	number	1 [4]
Tool cassette	number	[3] [4] [6]
Tool locations	number	[150] [200] [300]
Tool diameter max.	mm	125
... adjacent tool locations empty	mm	325 [400] <sup>1)</sup>
Tool length max.	mm	800 <sup>2)</sup>
Tool weight max.	kg	40 [50]
Tilting moment max.	Nm	50 [100]
Chip-to-chip time, tools up to 6 kg (VDI 2852)	approx. s	6,5
<b>Machine</b>		
Control, Siemens Sinumerik	type	840D sl
Space requirement basic machine, L x W x H	m	9,1 x 5,7 x 4,3
Machine weight	approx. kg	44 000

[...] = option,  
 1) = only in special cassette  
 2) = possible collision with the maximum interference circle diameter of the fixture

Subject to change without notice

All illustrations are exemplary.  
 Actual form and version of machines  
 may differ, depending on ordered type.

**ZUSE HÜLLER HILLE WERKZEUGMASCHINEN GMBH**

Steige 61, 74821 Mosbach, Tel. +49 6261 66-0, Fax +49 6261 66-369

[zuseautomation.com/huellerhille](http://zuseautomation.com/huellerhille)

---

SHAPE PRODUCTS. NOT PRODUCTION.

