



- Quality Is Our Nature
- In Search of Excellence
- LEADWELL Leads the Industry in Taiwan, in the World

**LEADWELL**  
LEADWELL CNC MACHINES MFG.,CORP.



**LEADWELL CNC MACHINES MFG.,CORP.**



NO.23, Gong 33th Road, Taichung Industrial Park  
Taichung 407, Taiwan  
TEL: 886-4-23591880  
FAX: 886-4-23592555  
E-mail: sales@leadwell.com.tw

**www.leadwell.com.tw**

※ All performance are based on 220V/3PH/60HZ. Specification are subject to change without notice.

***T/LTC Series***  
**CNC TURNING CENTER**  
**T-7A/T-7AM**  
**LTC-20D/LTC-20DM/LTC-20DMY**

## The Ultimate in Combining High Performance with Versatility and Value



- The Ultimate Combination of Power, Versatility & Value in a Linear Way Lathe

TRAVEL	T-7A	T-7AM
X axis	190+20mm	160+20mm
Z axis	450mm	450mm
Chuck Size	8	8
Bar Capacity	65mm	65mm

TRAVEL	LTC-20D	LTC-20DM	LTC-20DMY
X axis	190+20mm	160+20mm	160+35mm
Z axis	540mm	540mm	510mm
Chuck Size	8	8	8
Bar Capacity	65mm	65mm	65mm

### Live Tool Turret (Standard with T-7AM/LTC-20DM/LTC-20DMY)

- The live tool turret replaces the standard turret on T-7AM/LTC-20DM/LTC-20DMY turning centers. Each tool can become a rotating tool for both milling and drilling operations.
- Tools can be either radially or axially oriented.

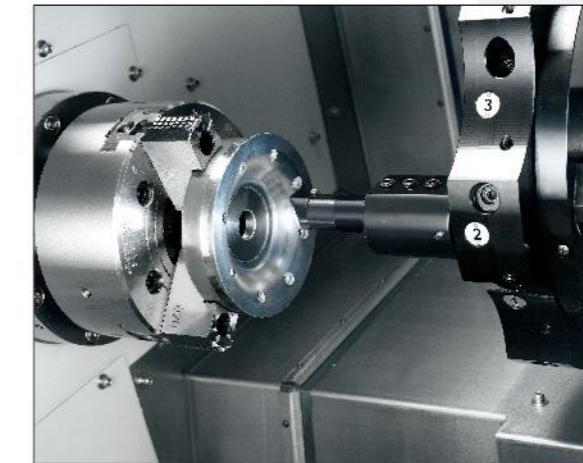

### CUTTING CAPACITY T-7A

O.D. Cutting	
Cutting Speed	340m/min
Spindle Speed	1320rpm
Feed Rate	0.4mm/rev
Depth of Cut	4mm
Removal Rate	544c.c/min

Groove Cutting	
Cutting Speed	140m/min
Spindle Speed	665rpm
Feed Rate	0.15mm/rev
Depth of Cut	4mm

Drilling	
Tool Size	42mm
Spindle Speed	1200rpm
Feed Rate	0.144mm/rev
Depth of Cut	40mm

Tapping	
Tool Size	M20
Spindle Speed	500rpm
Feed Rate	2.5mm/rev
Depth of Cut	25mm

### MACHINE ENCLOSURE

- T/LTC series machines are fully enclosed with splash guards and way covers.
- CE approved guarding is also available as an option.

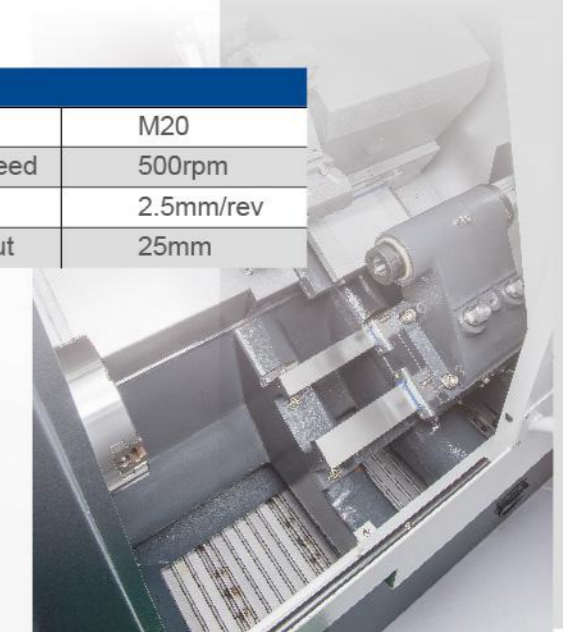

## STRUCTURE

### LEADWELL APPLIES ADVANCED CONCEPTS TO CREATE PERFECTION IN STRUCTURAL DESIGN.

LEADWELL uses only top quality well-ribbed castings.

Finite Element Analysis (FEA) is used on each new casting to determine the size and location of all internal ribs ensuring high torsional stiffness and minimum vibration.

The cast iron base, saddle, headstock, slide and tailstock are ruggedly constructed for superior stability and machining accuracy.

### EXTRA WIDE SPAN FOR INCREASED STABILITY

- The T/LTC series utilizes oversized box ways for high horse power machining. The extremely rigid body base frame with box ways provides outstanding stability for precision turning.

### 30° MASSIVE SLANT BED

#### Easy Chip Disposal

- The 30° degree slant bed design allows chips to fall directly into the chip tank, avoiding accumulation inside the machine.
- The chip tank employs large wheels, making it easy to move for chip removal and cleaning.
- Chain-type chip conveyor (optional) available on all models.

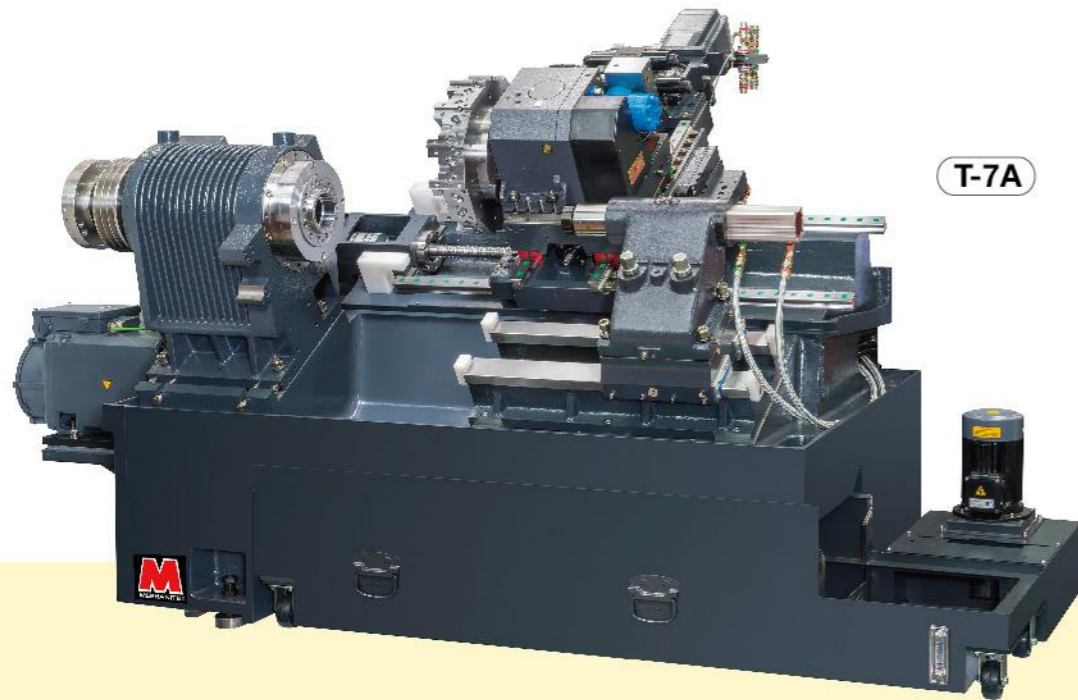

T-7A

### MORE POWERFUL

- Powerful main spindle 20HP
- Rigid 30° slanted cast iron base

### INCREASED CAPACITY

- 8 inch chuck standard
- Φ65mm bar capacity standard

### FASTER/ MORE PRODUCTIVE

- Fast rapid rates 20 ~30m/min
- Spindle speed 4000 rpm
- C axis and BMT 55 live tooling version available

### ERGONOMIC CONSIDERATIONS

- Easy to use membrane touch-pad control station.
- Easy moving operator door
- Parts catcher available
- No chip or coolant leaks

## STRUCTURE

### DIRECTLY COUPLED SERVO MOTORS

- T/LTC series servo motors are connected directly to the ball screws with rigid shaft couplings. These couplings ensure that even under severe loading from sharp corner machining, precise interpolation is achieved. This design is superior to both belt driven and flexible shaft coupling designs.



### HEADSTOCK

The headstock is a thermally symmetric design with heat dissipating fins for effectively increasing heat dissipation effect. This design prevents thermal distortion during long machining cycles.

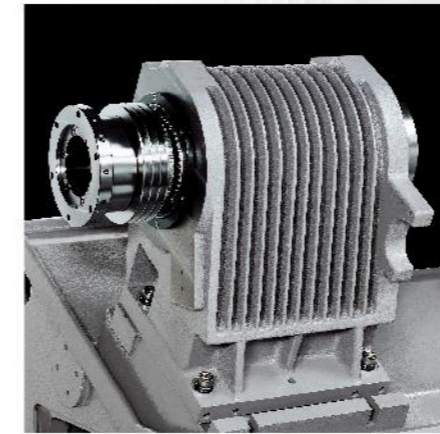

### SPINDLE

- Leadwell produces superior spindles. Built with high precision P4 grade bearings, the one-piece cartridge ensures precise alignment for smooth, run-out free operations.
- The massive headstock, rigid spindle and superior bearing design along with high RPM, all facilitate heavy stock removal and precision tolerances.
- Both the headstock and spindles are machined in a temperature-controlled environment and are assembled in a clean room.

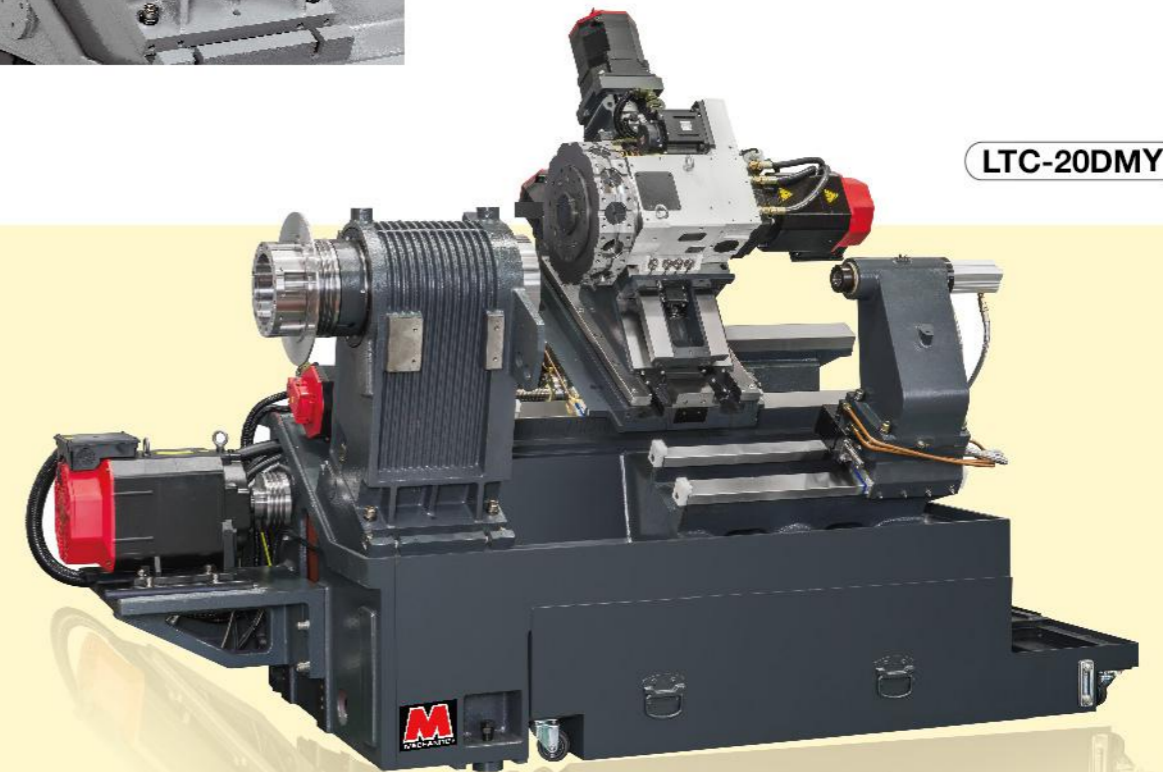

LTC-20DMY

# FEA REPORT(Finite Element Analysis)

## Optimum

- Section areas
- Moments of inertia
- Torsional constant
- Plate thickness
- Bending stiffness
- Transverse shear
- Vibration reduce

## With FEA you can

1. Predict and improve product performance and reliability.
2. Reduce physical prototyping and testing .
3. Evaluate different designs and materials .
4. Optimize designs.

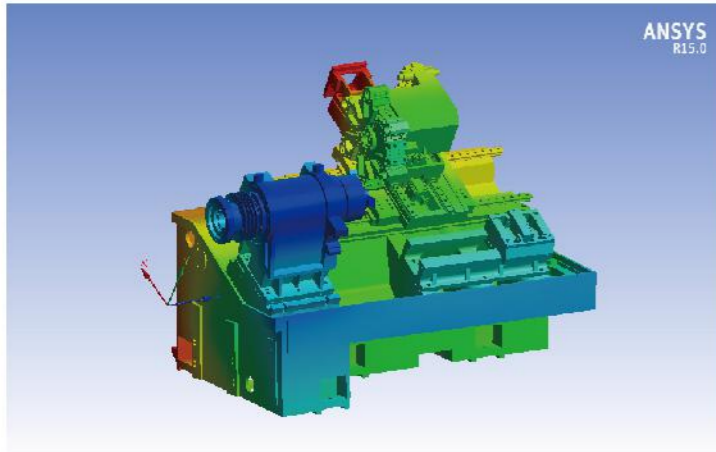

T-7A

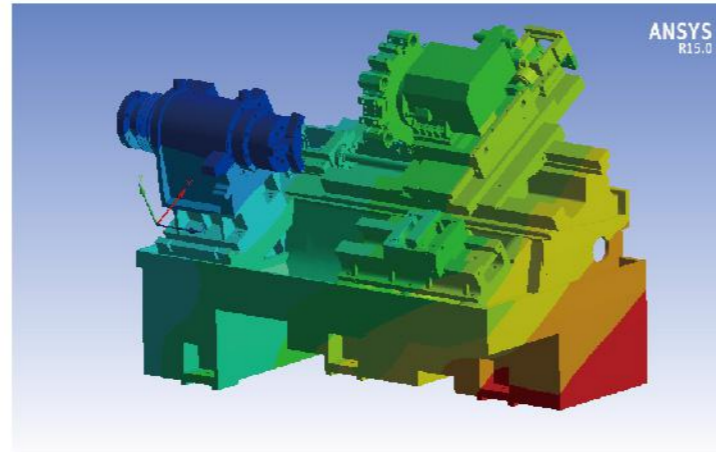

LTC-20D

## INDICATIVE CUTTING CAPACITY

FANUC  $\alpha 2$ (2.2/3.7kw) 23.5 N.m(S3-60%,10min)

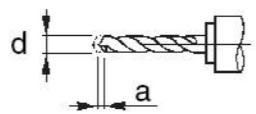
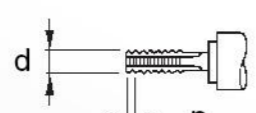
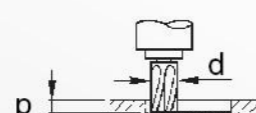
SIZE		BMT55	VDI30	
Twist drilling	d x a [mm] x [mm/u]		16X0.2	14x0,15
Tapping	d x p [mm] x [mm]		M16X2.0 M24X1.5	M10x1,5 M24x1
Slot milling	d x p x a [mm] x [mm] x [mm/min]		20x10x90	20x10x40

# FEATURE & QUALITY



## Tool Setter (Optional)

The tool setter has a touch sensor that can measure various tool lengths and detect broken tools. It can be easily programmed to store all the tool information to reducing tool change time.



## Parts Catcher (optional)

- Leadwell unique parts catcher improves productivity with the bar feeder option.
- The parts catcher automatically rotates to position under the finished part and transfers it outside the operator door. This eliminates the need to stop the machine and retrieve the finished parts.



## Bar Feeder (optional)

The bar feeder is suggested for unattended bar machining and high production requirements. It handles bars ranging from 5 to 65 mm. in diamter. Bar loading can be quickly accomplished. Easy parameter setting for various bar sizes.



## Collet Chuck (optional)

The spindle is available to mount with a collet chuck, providing faster chucking for bar stock. Various sizes of collet are supplied upon customers' request.

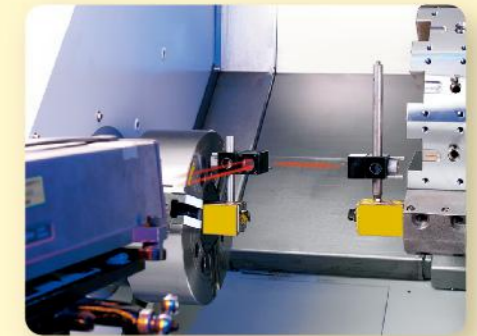

## LASER CALIBRATION

Lasers are used to measure the positioning accuracy of every machine over the full travel of each axis. Leadwell uses these measurements to compensate any axis error so that each machine meets the high accuracy requirements.

- Each machine is shipped with a positioning accuracy chart.

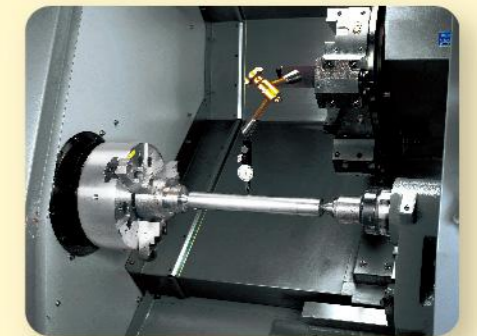

## MACHINE GEOMETRIC CHECKING

Precision indicators are used to verify that spindle run-out and headstock to tailstock alignment meet all specifications.



## CUTTING AND COOLANT TESTING

Each machine must complete rigorous cutting tests to ensure machine integrity. Coolant tests guarantee that all components are working properly and machines are 100% leak proof.

## 48 HRS NON-STOP RELIABILITY TEST

Each machines is cycled for 48 hrs to ensure the highest reliability

# SPINDLE POWER CURVE

- Continuous N-m
- 30 min N-m
- Continuous KW
- 30 min KW

# OUTLINE DIMENSION

unit : mm

**T-7A/AM(FANUC 0i-T)**  
**LTC-20D/DM( FANUC 0i-T)**  
**α 12/7000i**

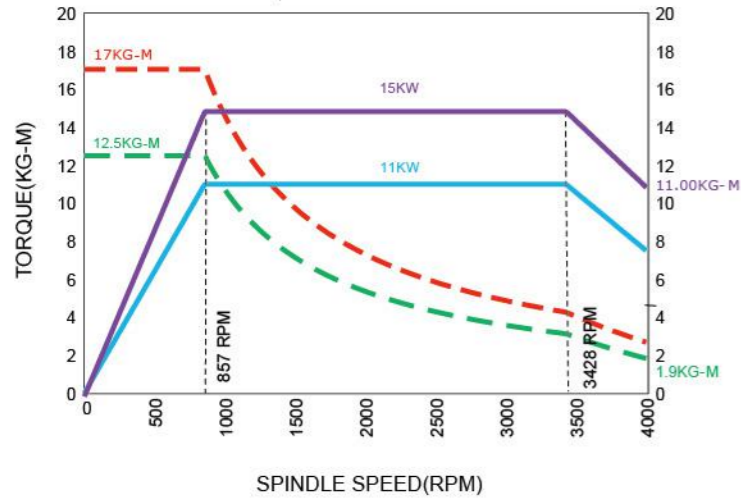

**T-7A (SIEMENS)**  
**1PH8131**

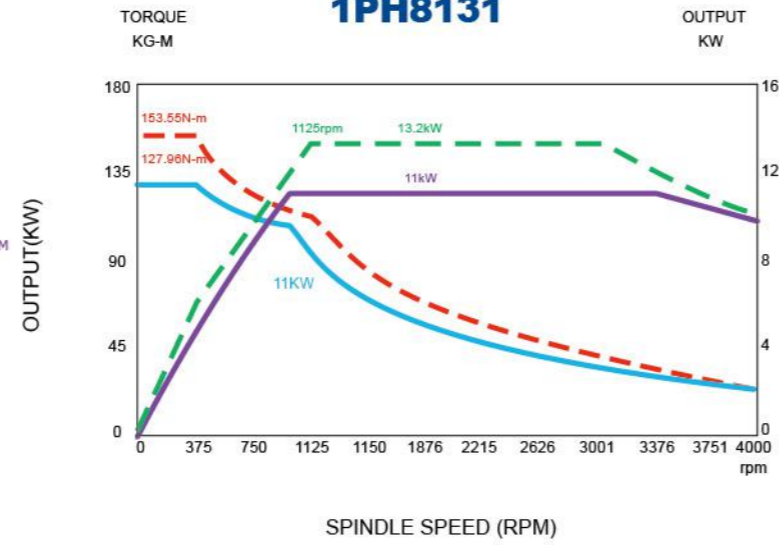

**T-7AM(SIEMENS)**  
**LTC-20D/DM(SIEMENS)**  
**1PH8133**

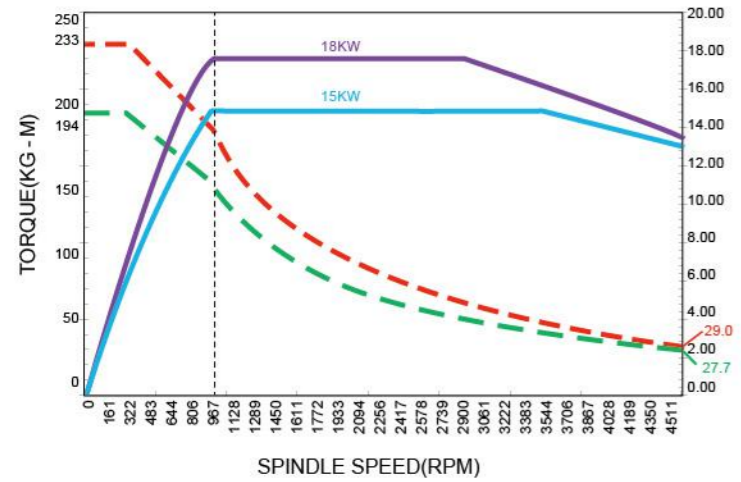

**LTC-20DMY (FANUC 0i-T)**  
**α12-7000i**

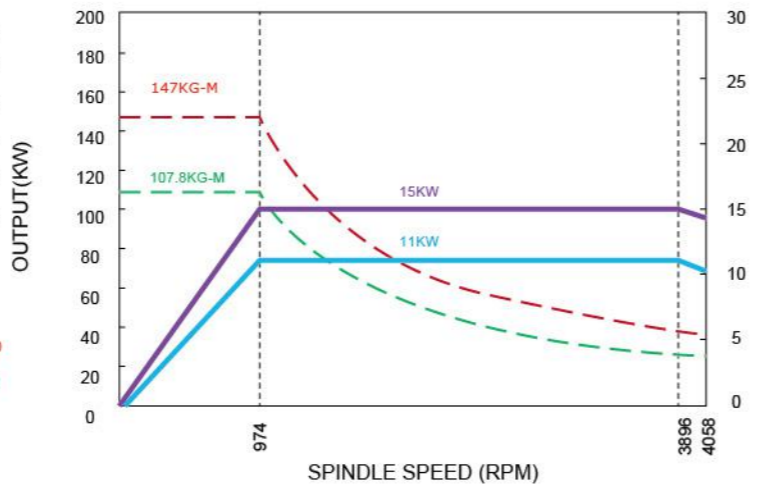

**T-7A**

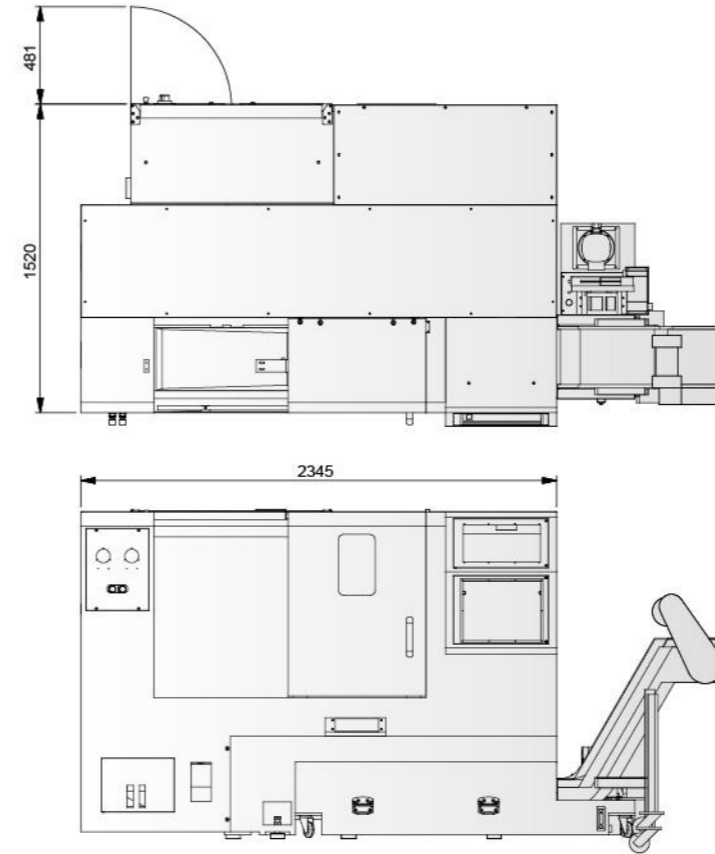

**T-7AM**

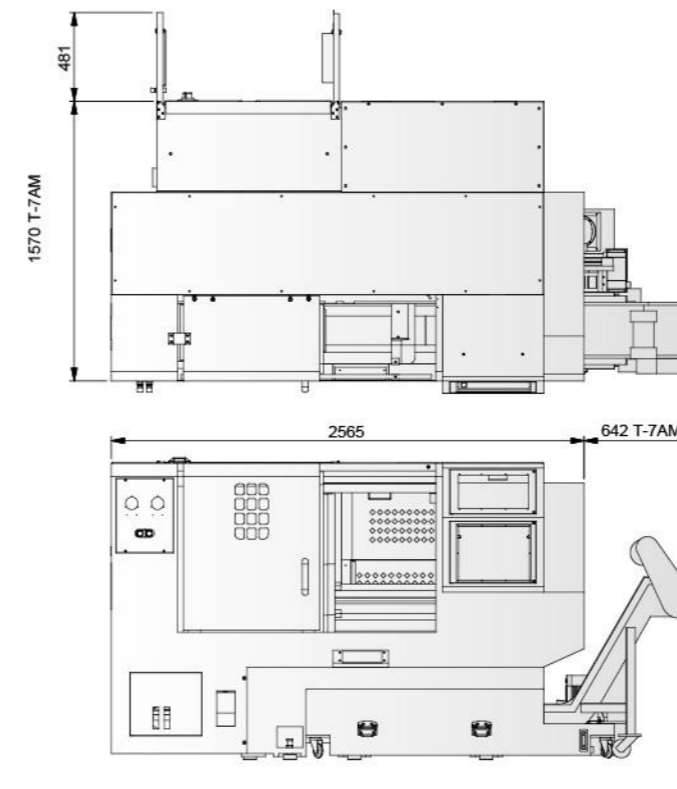

# OUTLINE DIMENSION

LTC-20D

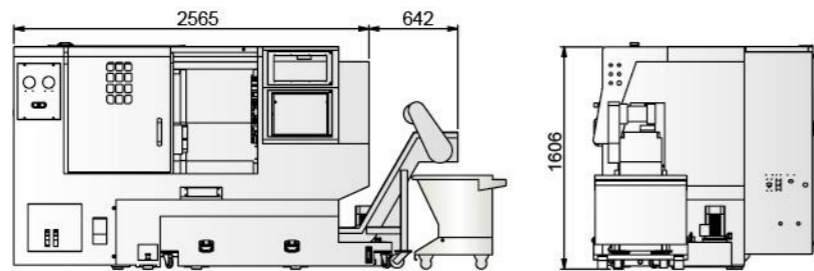
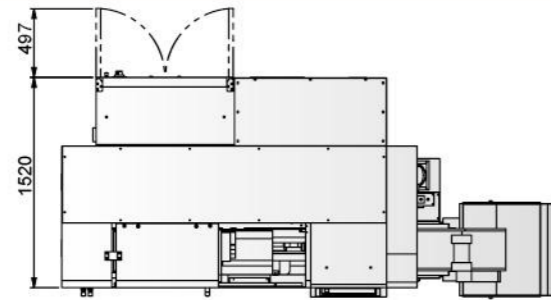

LTC-20DM

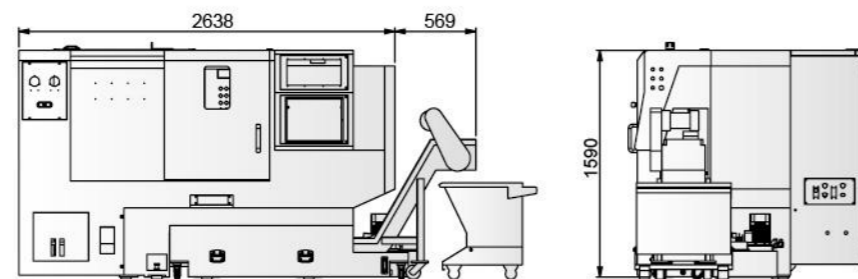
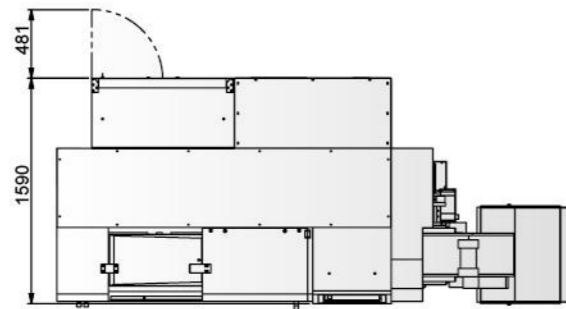

LTC-20DMY

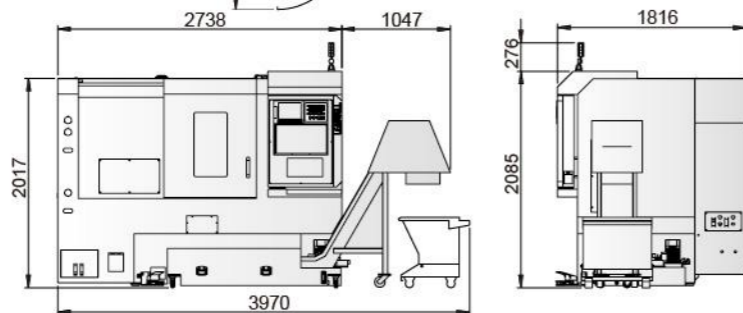
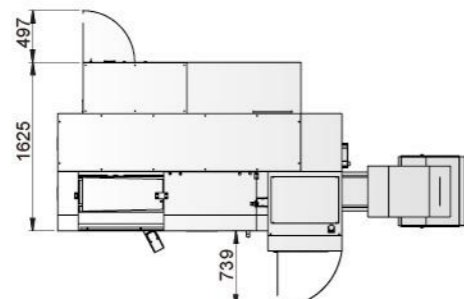

unit : mm

# TOOLING SYSTEM

T-7A

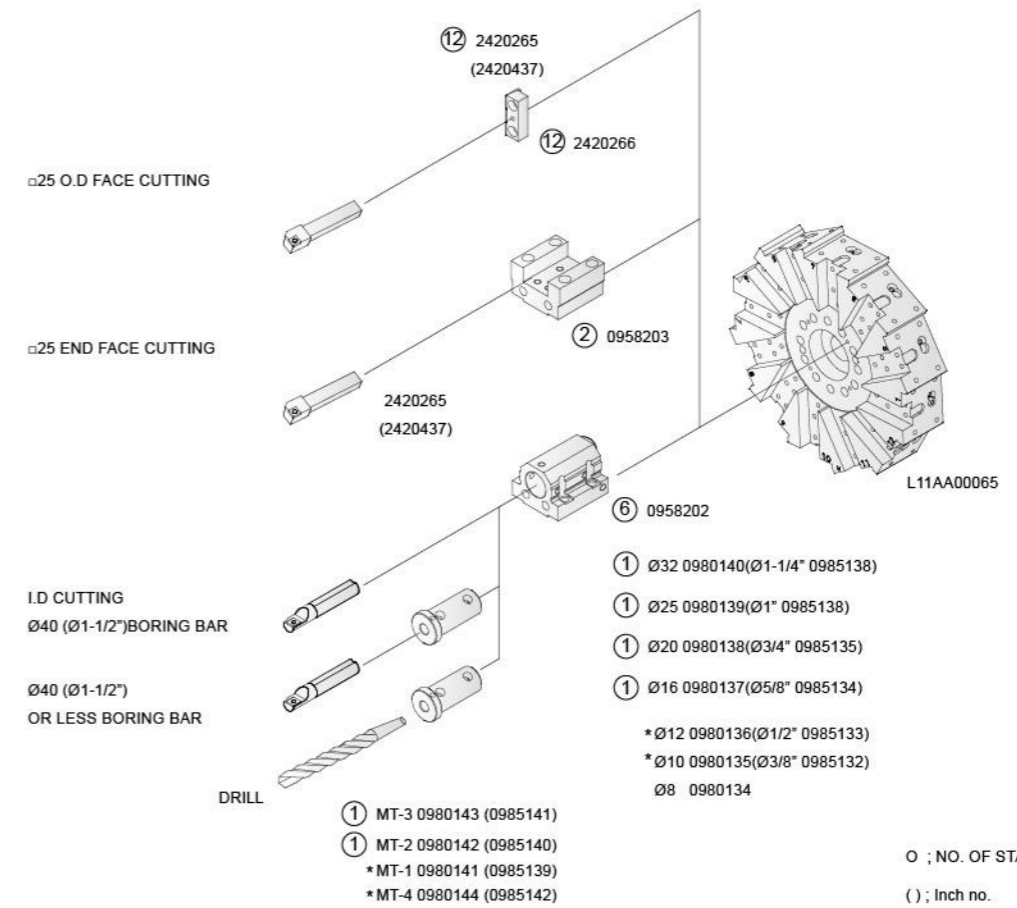

T-7AM

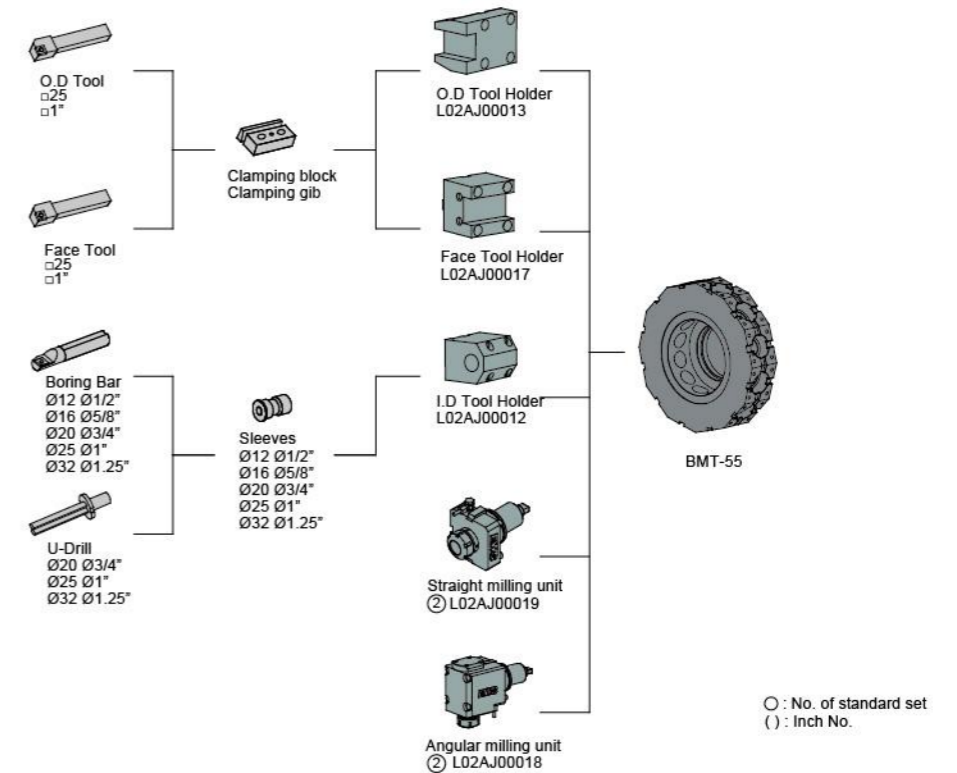

# TOOLING SYSTEM

## LTC-20D

O.D. & FACE CUTTING  
Ø25 (Ø1")

I.D. & FACE CUTTING  
Ø25 (Ø1")

I.D. CUTTING  
Ø40 (Ø1.5") BORING BAR

LESS BORING BAR  
Ø40 (Ø1.5")

DRILL

BORING BAR HOLDER  
I.D., Ø40 (Ø1.5")

BORING BAR SLEEVE

DRILL SOCKET  
MT-2 0980142000\*1 (0985140000)  
MT-3 0980143010\*1 (0985141000)

2420265010\*12

2420266020\*12

FACE & I.D. HOLDER  
0958203020\*2

BORING BAR HOLDER  
0958202020\*6

Ø32 0980140010\*1 (1-1/4" 0985138000)  
Ø25 0980139000\*1 (1" 0985137000)  
Ø20 0980138000\*1 (3/4" 0985135000)  
Ø16 0980137000\*1 (5/8" 0985134000)  
Ø12 0980136000\*1 (1/2" 0985133000)

12 POSITION TURRET HEAD



## LTC-20DM

Clamping block  
Clamping gib

O.D. & FACE CUTTING  
Ø25 (Ø1")

Boring Bar SLEEVE

BORING BAR Ø32 (Ø1-1/4")

DRILL Ø32 (Ø1-1/4")

O.D. Tool Holder  
L02AJ00013 (OPT)  
BMT55 DW230-C25-30L

Boring Bar Tool Holder  
L02AJ00014 (OPT)  
BMT55 DW230-B40

Power Tool Holder  
L02AJ00019\*2  
DW230-DA55-25

Power Tool Holder  
L02AJ00018\*2  
DW230-DF55-25-60

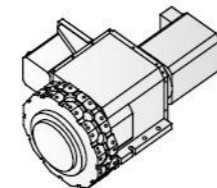

BMT-55 POWER TURRET

## LTC-20DMY

I.D. FACE CUTTING  
Ø25(1")

O.D. FACE CUTTING  
Ø25(1")

I.D. COLLET  
40(1.5")BORING

I.D. COLLET  
32(1-1/4")BORING

DRILL

DRILL  
2-16

END MILL  
2-16

FACING HOLDER  
DW230-F25-60  
L02A00017

TURNING HOLDER  
DW230-C25-30L  
L02AJ00013

BORING BAR HOLDER  
DW230-B40-70  
L02AJA4070

① E40-32(L04AA00008)  
① E40-25(L0200007)  
E40-20  
E40-16

E40-MT-1  
E40-MT-2  
E40-MT-3  
E40-MT-4

COLLET  
(ER25/2-16)

ROTATORY TOOLHODLER  
(RADIAL UNIT)  
L02AJ00019

ROTATORY TOOLHODLER  
(AXIAL UNIT)  
L02AJ00018

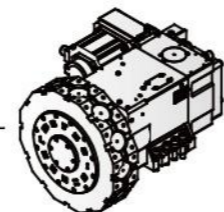

L11AAEZR20  
○:NO. OF STAND SET  
():INEH SIZE

# TOOLING INTERFERENCE

## T-7A

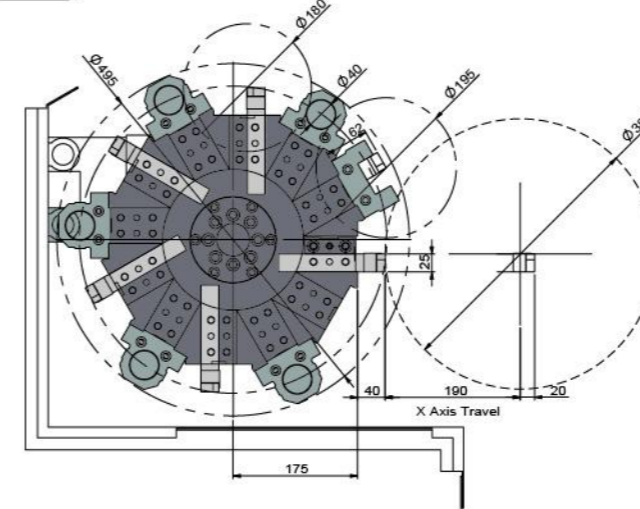

## T-7AM

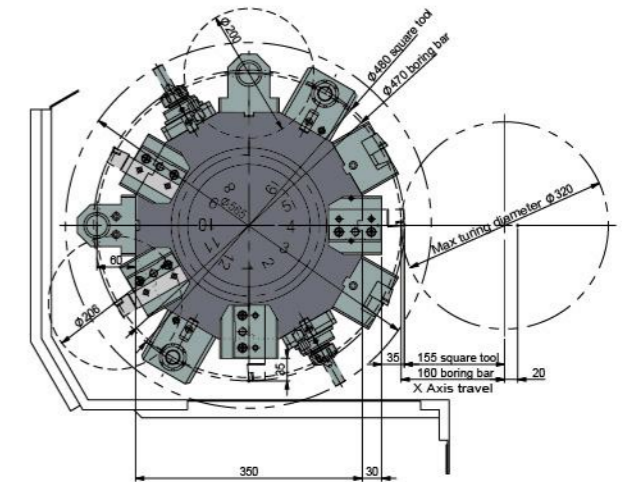

## LTC-20D

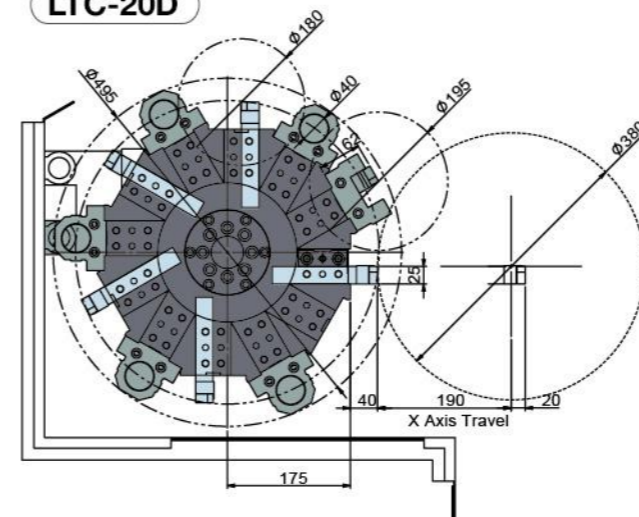

## LTC-20DM

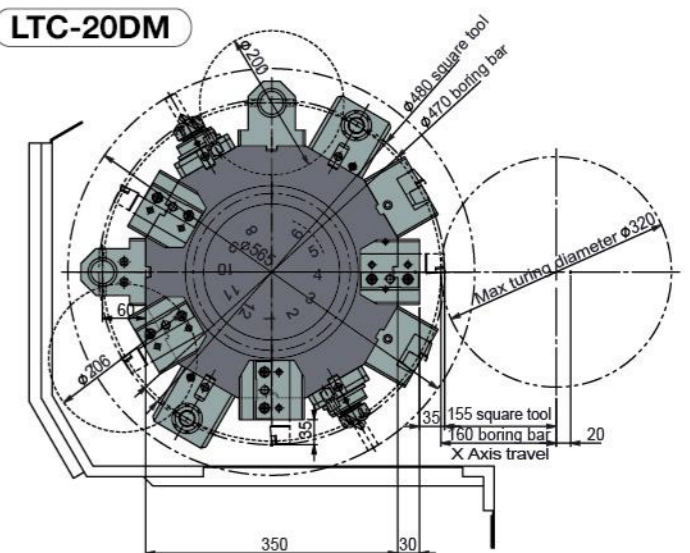

## LTC-20DMY

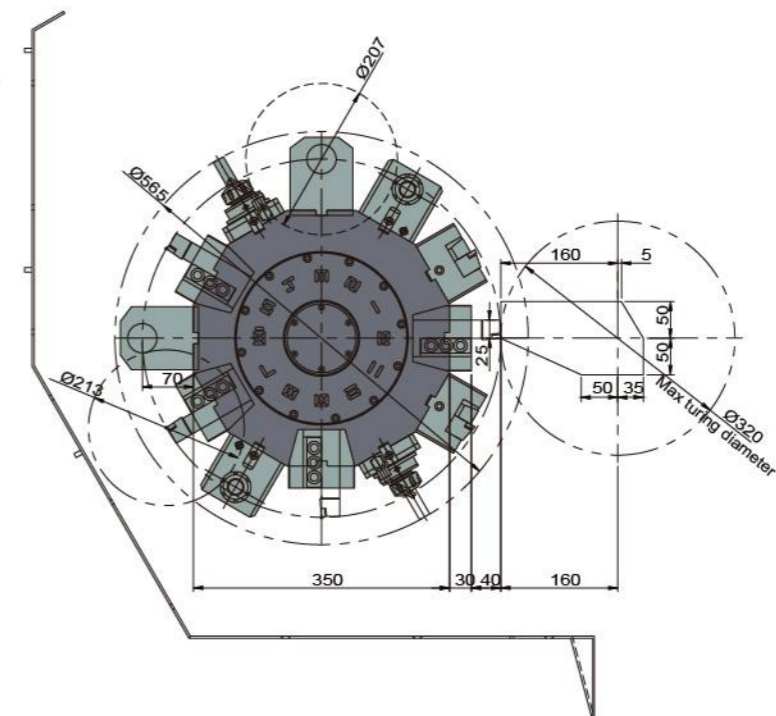

# WORKING CAPACITY

**T-7A** □ 25/φ40/12T

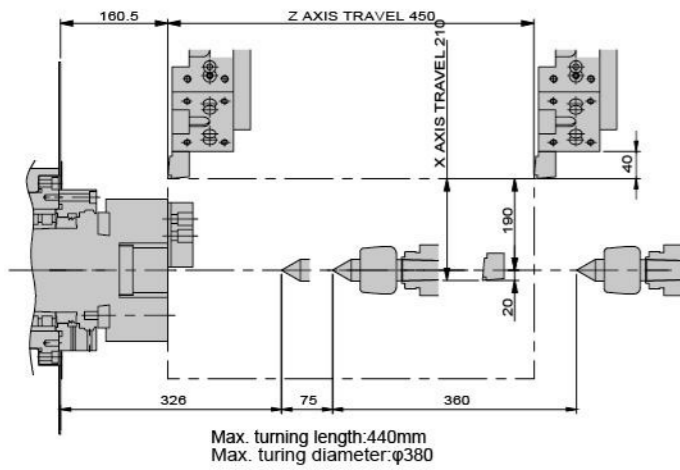

**T-7AM** □ 25/φ40/12T

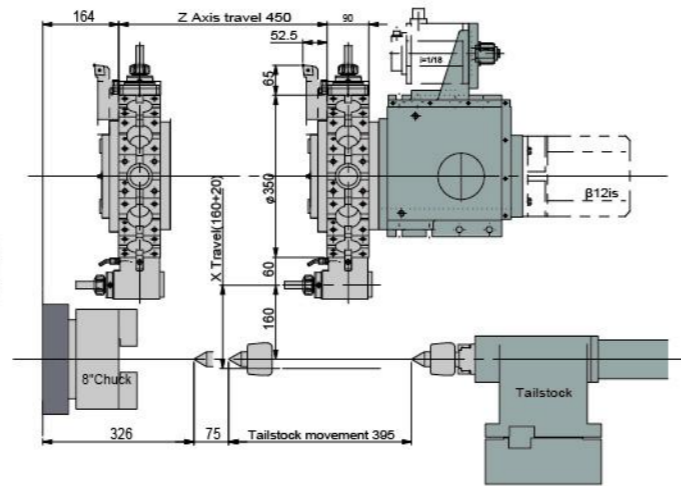

**LTC-20D**

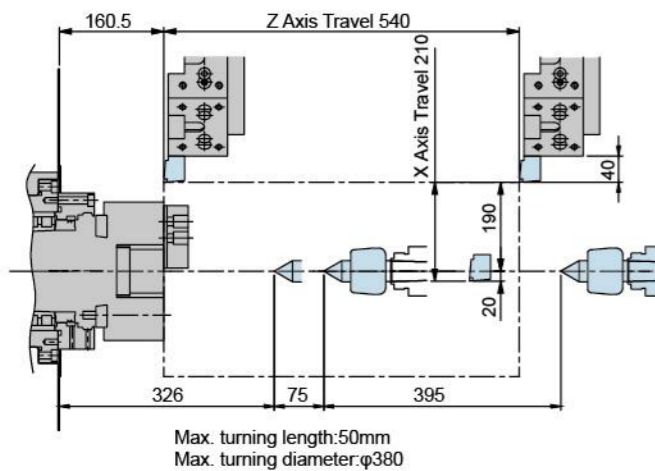

**LTC-20DM**

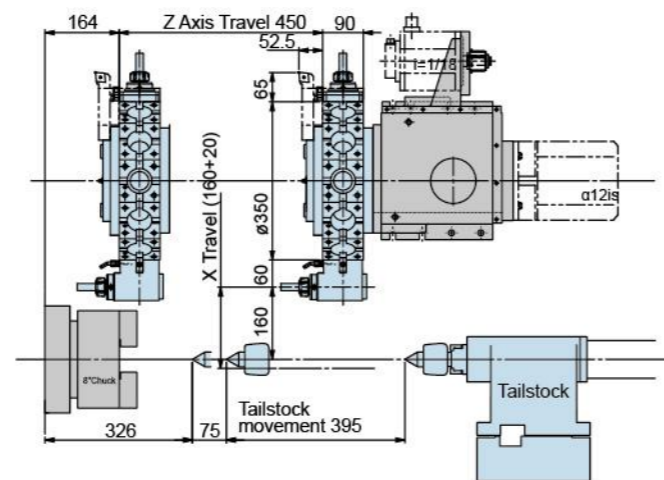

**LTC-20DMY**

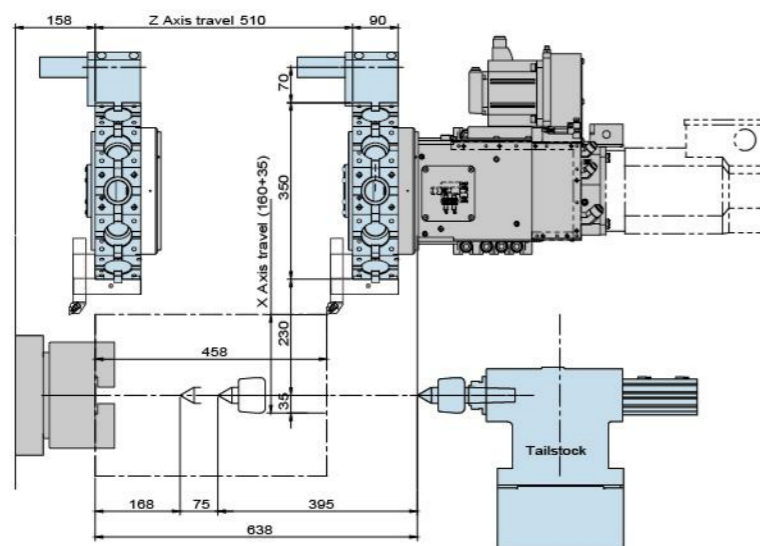

# MACHINE SPECIFICATIONS

ITEM	MODEL	T-7A	T-7AM	LTC-20D	LTC-20DM	LTC-20DMY
<b>CAPACITY</b>	Unit					
Max. swing	mm(in)	500(19.7)	540(21.2)	500 (19.7)	540 (21.2)	570(22.4)
Max. turning diameter	mm(in)	380(14.9)	320(12.5)	380 (15)	320 (12.5)	320(12.5)
Max. turning length	mm(in)	440(17.3)	400(15.7)	500 (19.7)	430 (16.9)	458(18)
Bar capacity	mm(in)	65(2.5)	65(2.5)	65 (2.5)	65 (2.5)	65(2.5)
<b>TRAVEL</b>						
X axis travel	mm(in)	190+20(7.5+0.8)	160+20(6.2+0.8)	190+20 (7.5+0.8)	160+20 (6.2+0.8)	160+35(6.2+1.37)
Z axis travel	mm(in)	450(17.7)	450(17.7)	540 (21)	540 (21)	510(20)
<b>SPINDLE</b>						
Spindle speed	rpm	4000	4000	4000	4000	4000
Chuck size	in	8	8	8	8	8
Type of spindle nose		A2-6	A2-6	A2-6	A2-6	A2-6
Spindle motor power	kw(hp)	15(20)	15(20)	15 (20)	15 (20)	15(20)
<b>TURRET</b>						
Number of tool stations	pcs	12	12	12	12	12
Shank height for square tool	mm(in)	25(1)	25(1) BMT 55	25 (1)	25 (1) BMT55	25(1) BMT 55
Shank diameter for boring bar	mm(in)	40(1.5)	40(1.5) BMT 55	40 (1.5)	40 (1.5) BMT55	40(1.5) BMT 55
Rotary tool spindle speed range: axis units	rpm	---	5000	---	5000	6000
Rotary tool spindle speed range: radial units	rpm	---	5000	---	5000	6000
Rotary tool motor power	kw	---	2.2(3)	---	2.2(3)	3.7(5)
<b>FEED RATE</b>						
X/Z axis rapid traverse	m(in)/min	30(1181)	30(1181)	20 (787.5)	20 (787.5)	30(1181)
<b>FEED MOTORS</b>						
X/Z axis motor	kw(hp)	3(4)	3(4)	3 (4)	3 (4)	3(4)
<b>TAILSTOCK</b>						
Quill diameter	mm(in)	75(3)	75(3)	75 (3)	75 (3)	75(3)
Quill inside taper	M.T	4	4	4	4	4
<b>MACHINE SIZE</b>						
Height of machine (H)	mm(in)	1780(70)				2170(85.4)
Floor space (LXW)	mm(in)	2745x1682(108x66)				2680x1625(105.5x64)
Total machine weight	kg	4000				4600
Power requirement	KVA	30	35	30	35	35
Controller	FANUC					0i-T

\*AVAILABLE CONTROLLER:SIEMENS

## STANDARD ACCESSORIES

- Metric disc (T-7A/LTC-20D)
- BMT 55 disc (T-7AM/LTC-20DM/LTC-20DMY)
- Manual tailstock
- Buzzer
- Heat exchanger
- Full enclosed splash guard
- 3 jaw open center chuck
- Foot switch
- High pressure pump
- Programmable tailstock (LTC-20DMY)

## OPTIONAL ACCESSORIES

- Auto door
- Spindle air outer blow
- Chip conveyor & bucket
- Collet chuck
- Transformer
- Bar feeder
- Parts catcher
- Alarm lamp
- Air conditioner
- Oil mist collector
- Tool setter
- Robot
- 3 jaw close center chuck