

The Ultimate in Performance



iT Series

V-30iT/V-32iT
V-20iT/V-40iT/V-60iT
5 Axes Machining Center

LEADWELL
LEADWELL CNC MACHINES MFG., CORP.



LEADWELL CNC MACHINES MFG., CORP.



No. 23 Gong 33th Road, Taichung Industrial Park
Taichung 407, Taiwan
T: 886 - 4 - 23591880
F: 886 - 4 - 23592555, 886 - 4 - 23593875
E: sales@leadwell.com.tw

www.leadwell.com.tw

* All performance are based on 220V/3PH/60HZ. Specifications are subject to change without notice.

2018.02

5 AXES MACHINING CENTER

• V-30iT

The rotary table is a compact dual-axil turning table that provides high-speed , accurate positioning for 3+2 and full 5 axis machining of small parts. Its small size and light weight make perfect 5 axis solution for even the smallest machining centers. With fix table design, provides the flexible and dual machining solution.



OP1:Fix table machining
OP2:Rotary table 5 face machining

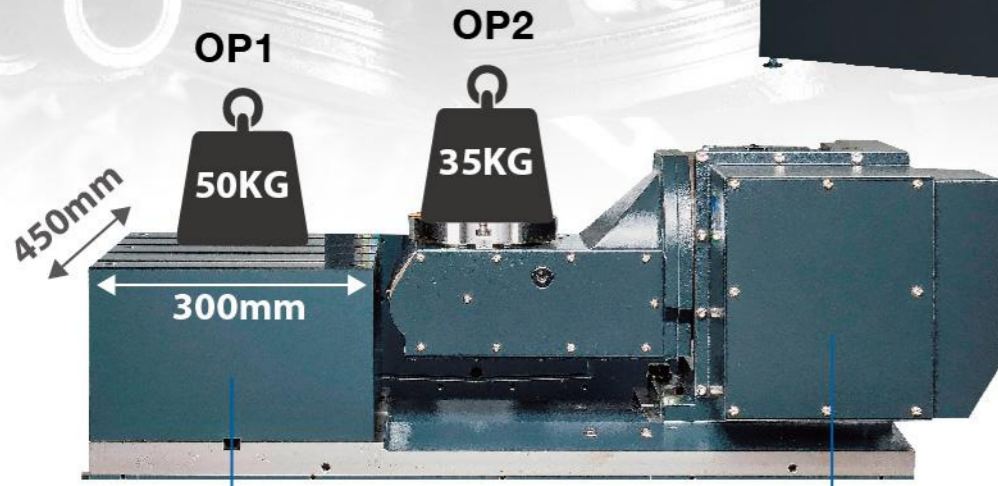

Fixture available

Mass of workpiece weight:

Level (0°~45°) :35kg

Titling (45°~90°) :25kg

1. High Rigidity:

- * FEA Analysis
- * High rigidity structure design
- * Roller type guide way
- * 3 Axis ball screw prestressing

2. High Reliability:

- * Roller type motion system
- * 3 Axis absolute motor

3. High Efficiency:

- * High torque spindle motor
- * Rapid feed rate 48/48/36mm
- * Spindle speed 12000 rpm
- * Tool change time TT/CC 1.8/4 sec

4. High Flexibility:

- * 45 axis rotary table available
- * Linear Scale available

FEATURE

- The iT series optimally concentrate the machining process for multiface, intricately shaped parts, and some difficult position of workpiece where 3-axis machines can't overcome, such as under cut.
- For depth mould, the iT series still can keep high efficiency machining by setting a suitable angle of tool, shorten the length of tool holding.
- Avoiding accumulative error from series machining procedure, decreasing total cutting time that substantially achieve the request:High Speed, High Accuracy, High Efficiency.
- 3-axis program still can run under constant position setting for A/C axis (without any cutting interference)

- High rigid cast iron construction with closed type design.
- Machine stable design supporting by big span saddle and foundation screws.
- Without counter weight enhance the accuracy on mold making as well as avoid vibration.
- Z axis transmission end fixed, as well as ball screw pretension, which enable to reduce the temperature.
- Minimal rapid traverse: 36 M/minute.

Parts with odd-angles and complex curved surfaces



Face Cutting

Grip Cutting

Grip Cutting with Swing

Grip Cutting with Slant

Grip Cutting While rotating

The advantages of 5 axes machining:

- Reduced machining time: By using a flat bottom endmill and maintaining perpendicularity to the complex surface you can step-over the full diameter of the cutter thereby dramatically reducing the required number of passes across a surface. The same principle applies to side mill of angled surfaces.
- Better surface finish: Using a flat bottom endmill to maintain perpendicularity to the complex surface can eliminate ribbing caused by ball-nose endmills.
- Eliminate multiple setups required to re-position the work-piece at complex angles.
- Eliminate costly tooling and fixtures required to hold the work-piece in place.
- Eliminate manual millwork and handwork required to cleanup rough surfaces.
- Machine complex parts that are not otherwise possible, including holes required to be normal to a complex surface.

RIGID CONSTRUCTION

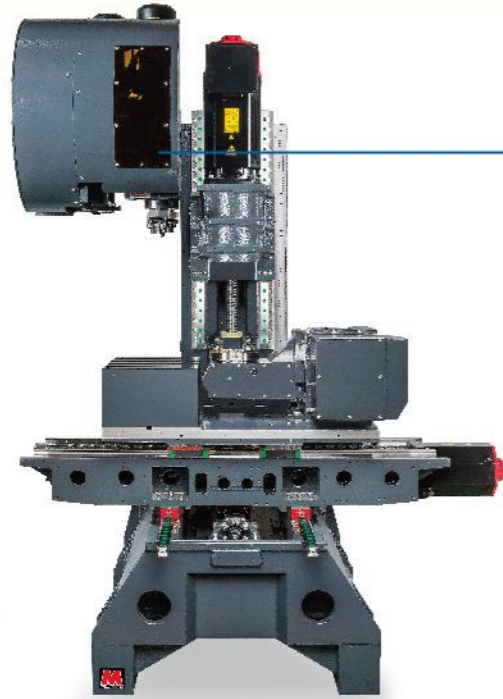

·V-30iT

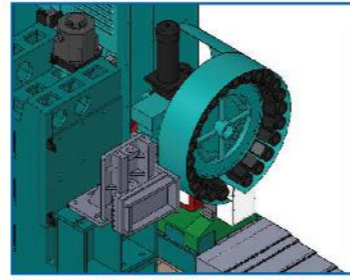

Lower the ATC magazine for shipment

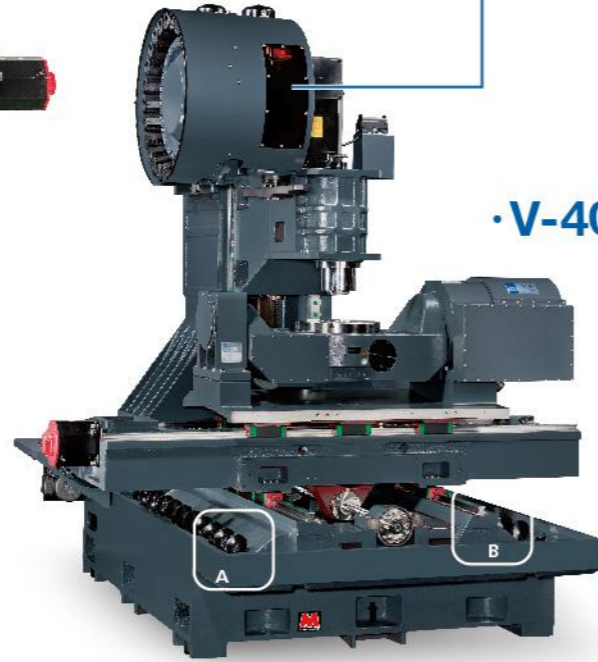

·V-40iT

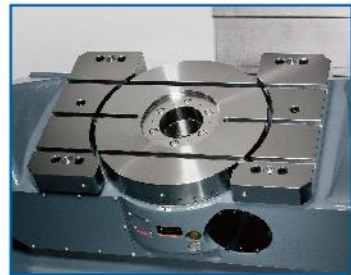

A) Chip Removal

LEADWELL's simple and efficient design uses chip augers on both sides of the machine and provides high volume coolant to wash the chips from the work area.

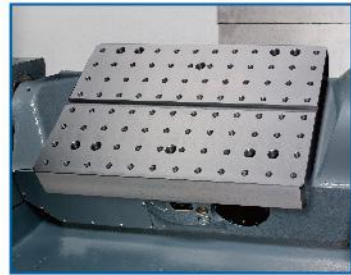

B) Roller Guide Ways

LEADWELL uses roller guide ways that feature zero clearance and fully-loaded carrying capacity in all directions.

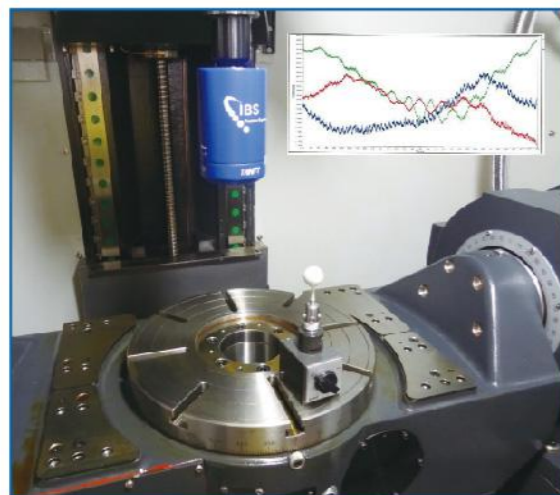

Volumetric Accuracy Control

Leadwell optimizes the parameter data and consequently dominates the total acceptance of the machine.

FEA REPORT(Finite Element Analysis)

Optimum

- Section areas
- Moments of inertia
- Torsional constant
- Plate thickness
- Bending stiffness
- Transverse shear
- Vibration reduce

With FEA you can:

1. Predict and improve product performance and reliability.
2. Reduce physical prototyping and testing .
3. Evaluate different designs and materials .
4. Optimize designs .



LEADWELL SMART PROCESSOR

More than a machine

Leadwell is never simply about building a machine and to launch onto the market. Our years of experience, we learn that the right programs must be developed to ensure the competitiveness of the users.

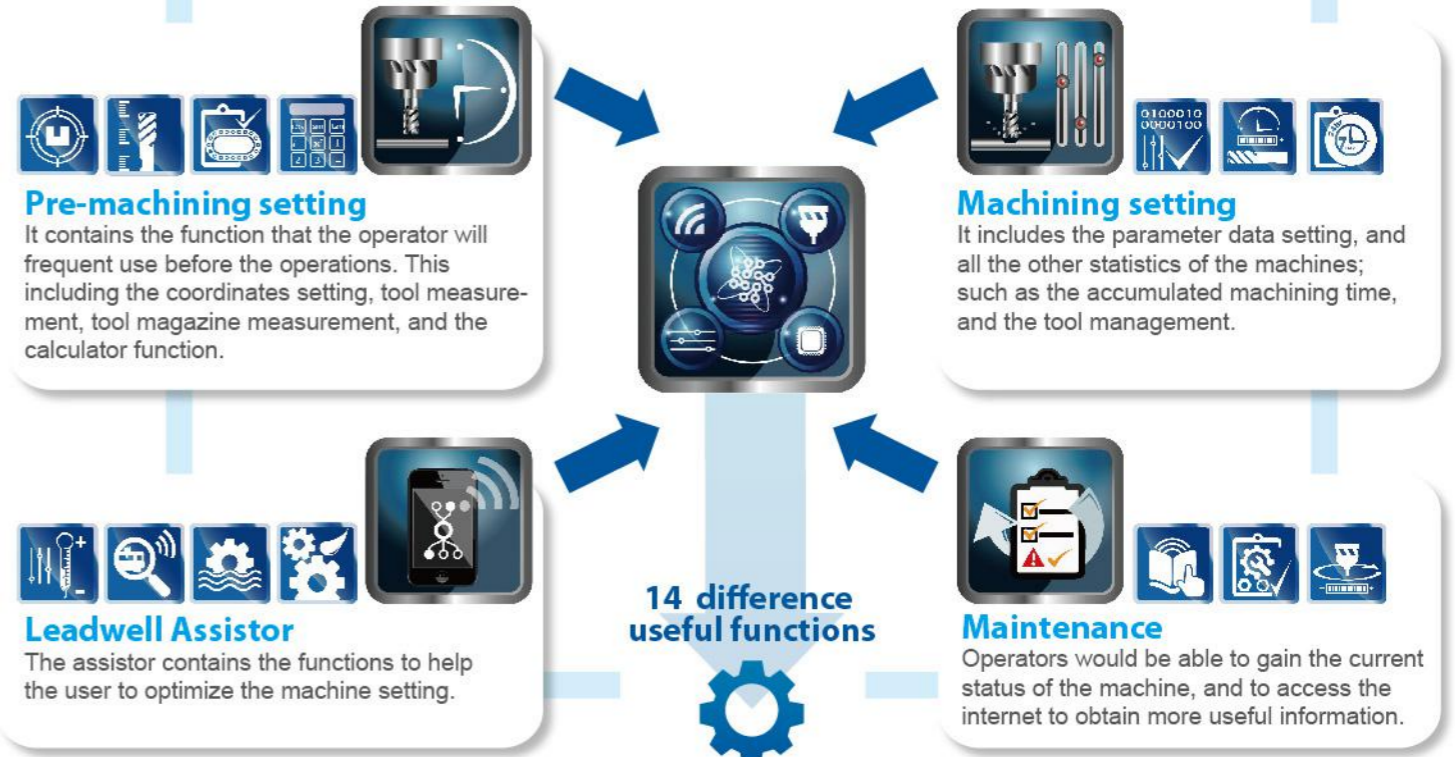

Machined work pieces.

Users' full satisfaction have always been Leadwell's main focus.

INDUSTRIAL APPLICATIONS

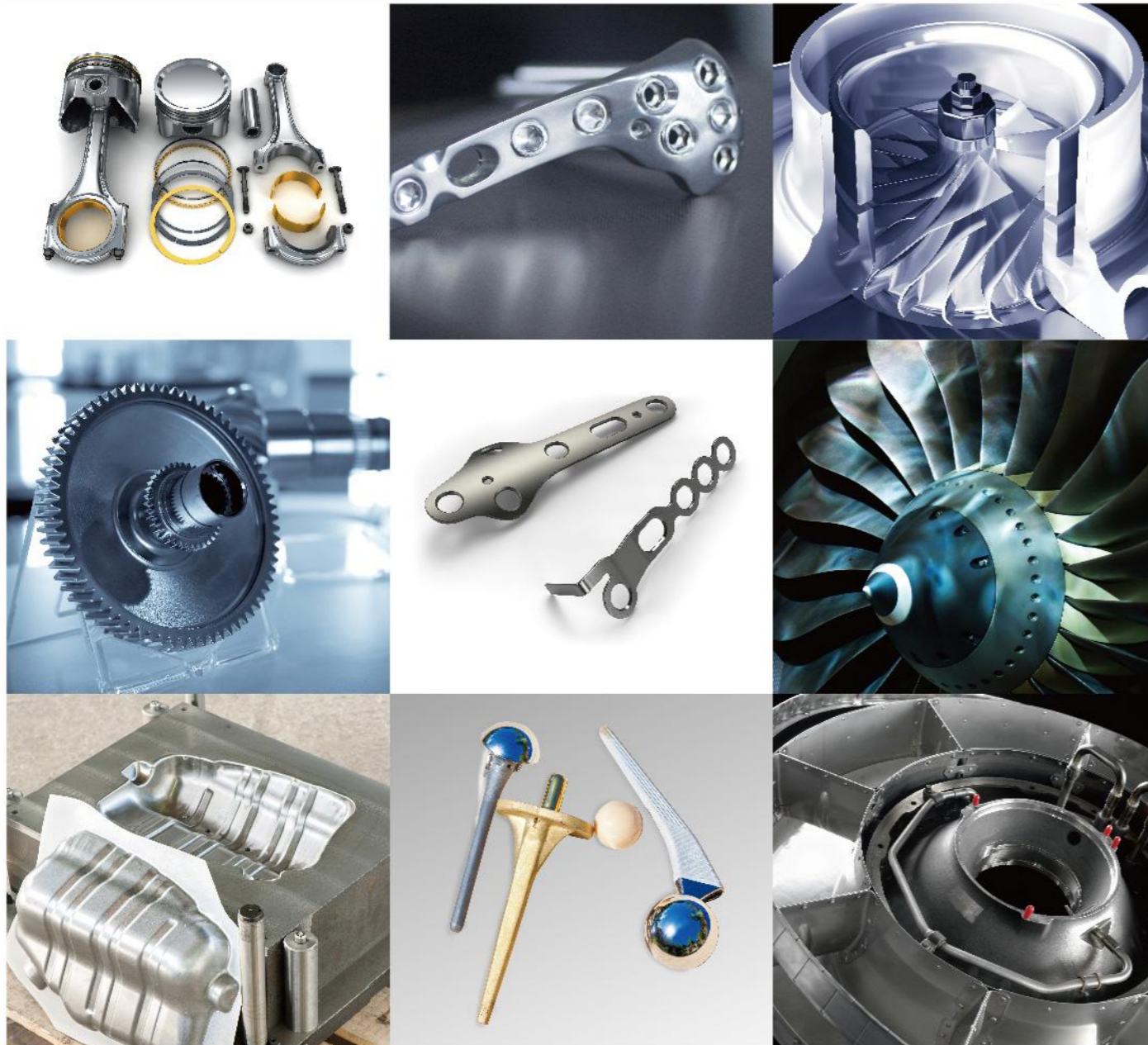
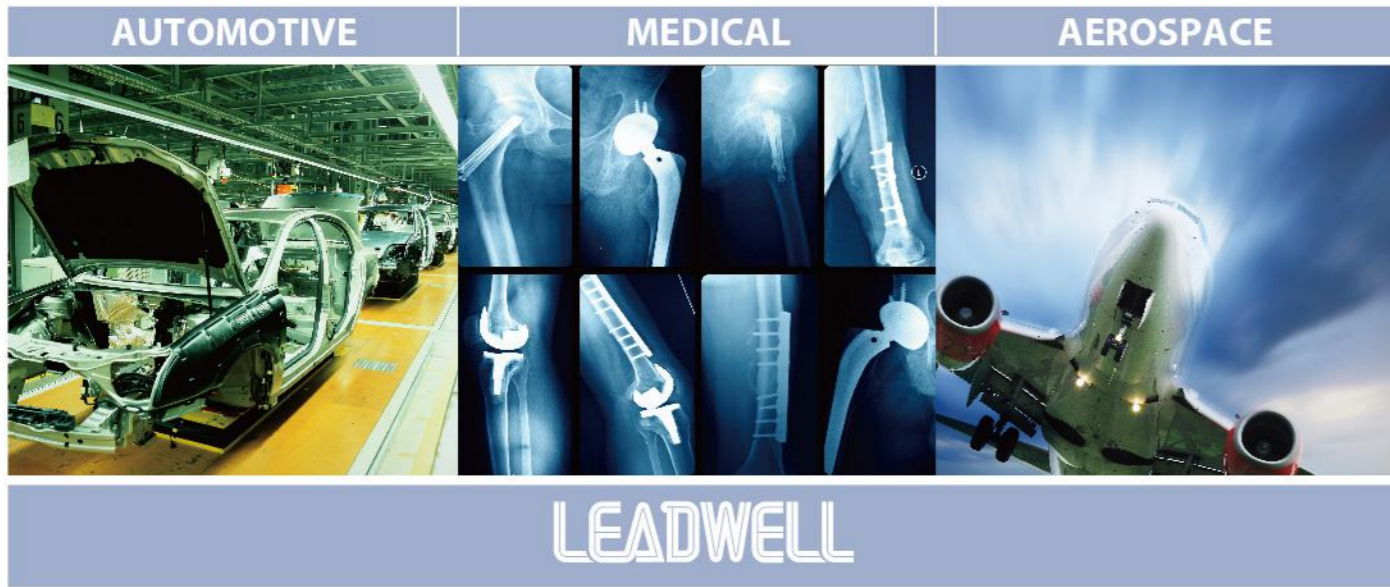

SPINDLE POWER CURVE

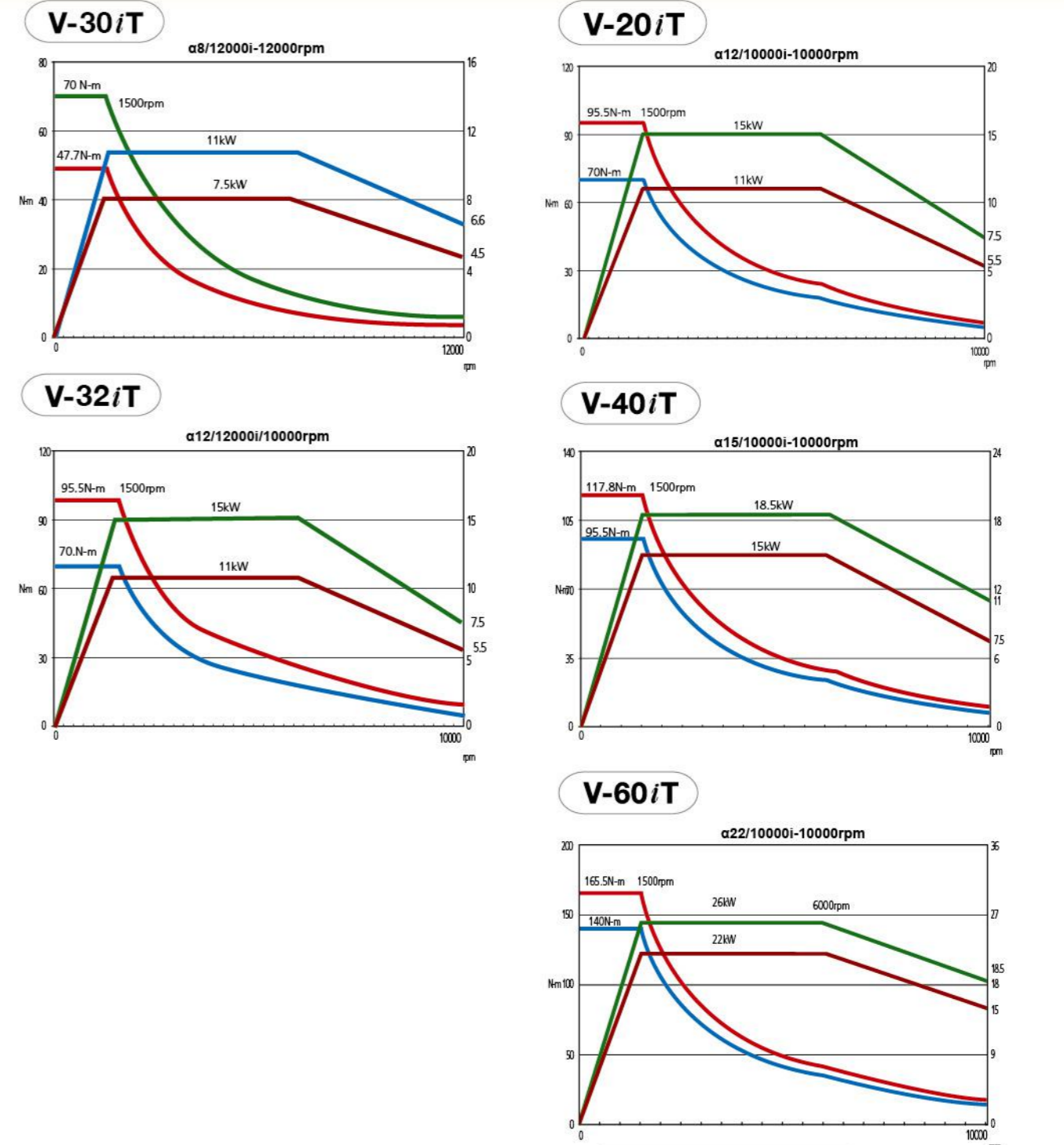

— (Low)Cont. Spindle torque(N-m)
— (Low)30 min Spindle torque(N-m)
— (Low)Cont. operating zone(KW)
— (Low)30 min operating zone(KW)

Unit:mm

Tool Drawing BT-40 with CTS & BT-40

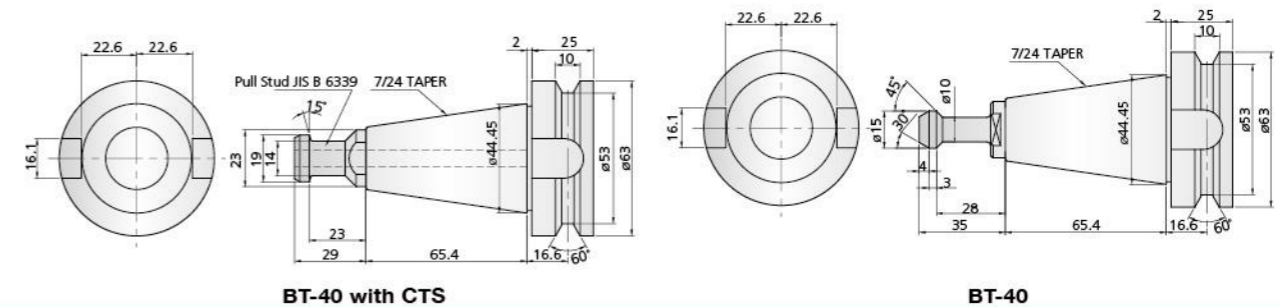

FIXTURE PLATE DIMENSION

V-30iT

STD

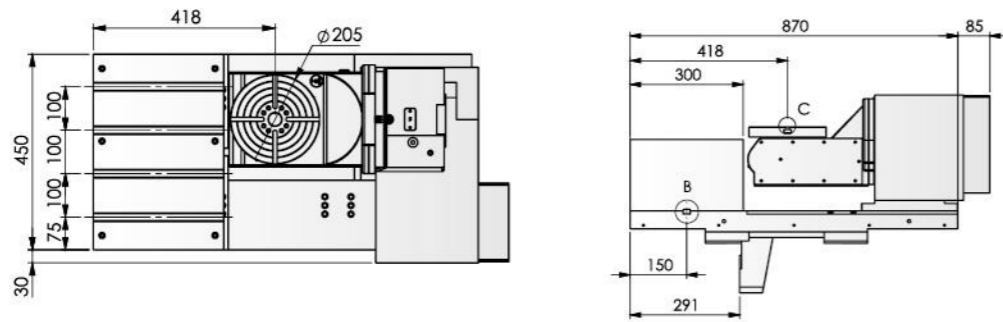

OPT

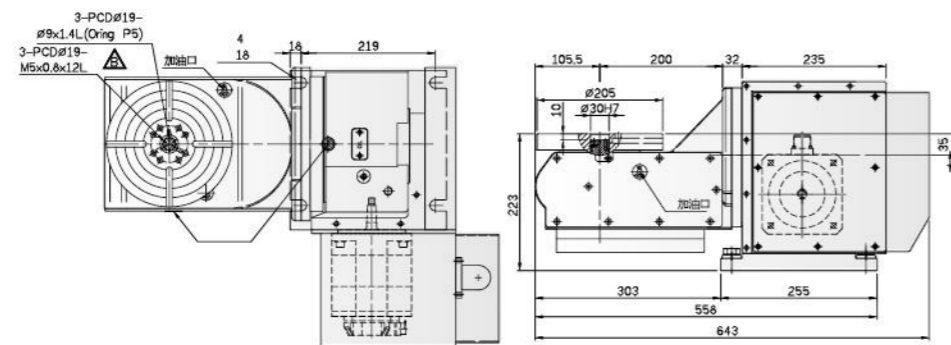

FIXTURE PLATE DIMENSION

V-32iT

STD

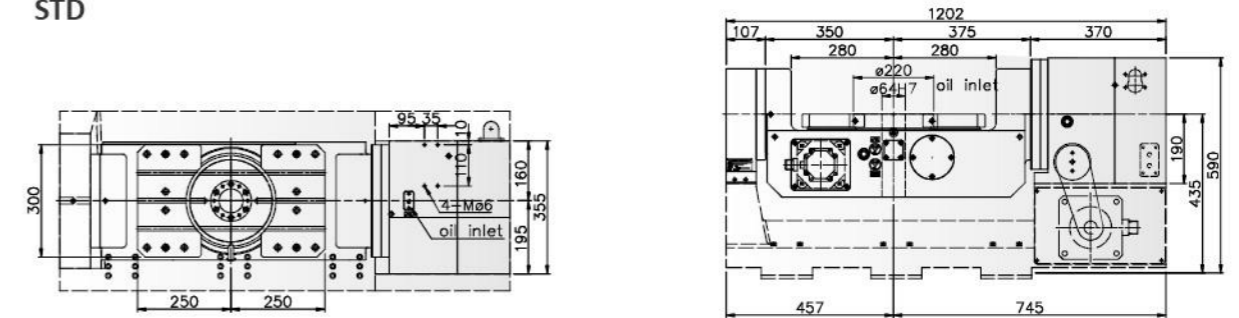

OPT

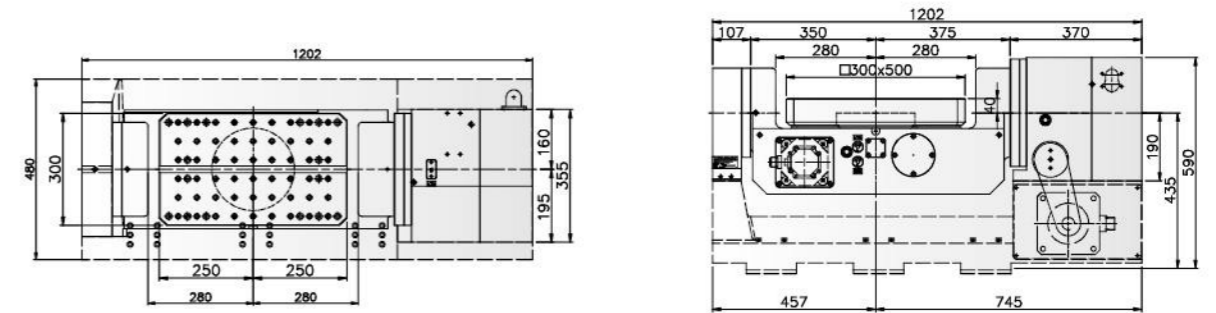

OPT

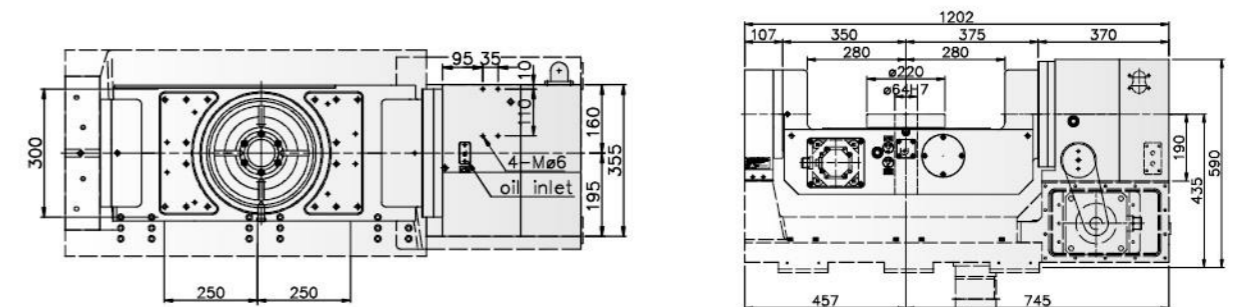

FIXTURE PLATE DIMENSION

FIXTURE PLATE DIMENSION

V-20iT

Unit:mm

STD

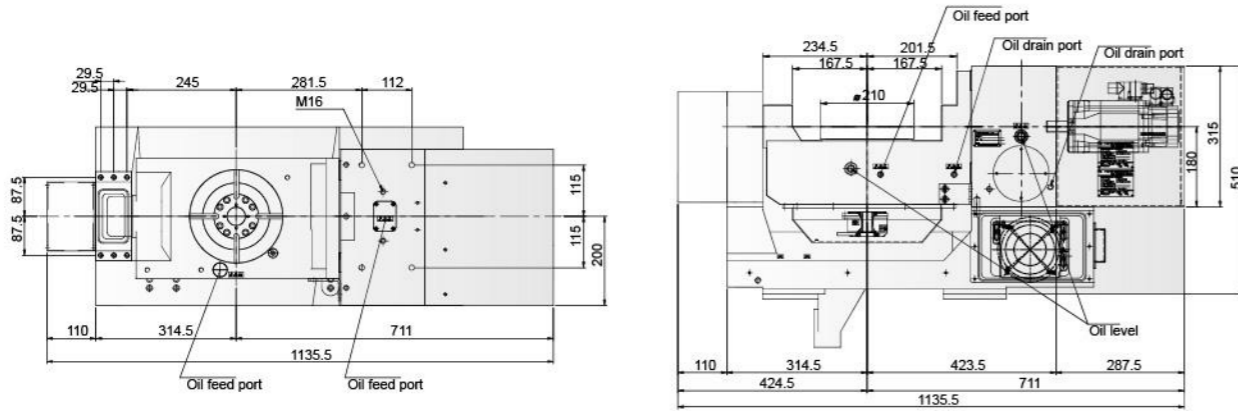

V-60iT

STD

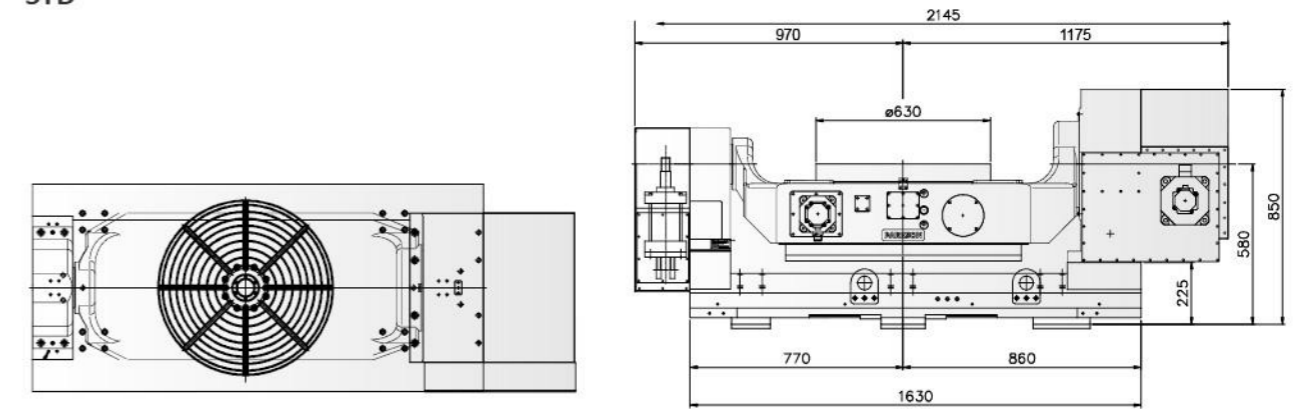

V-40iT

STD

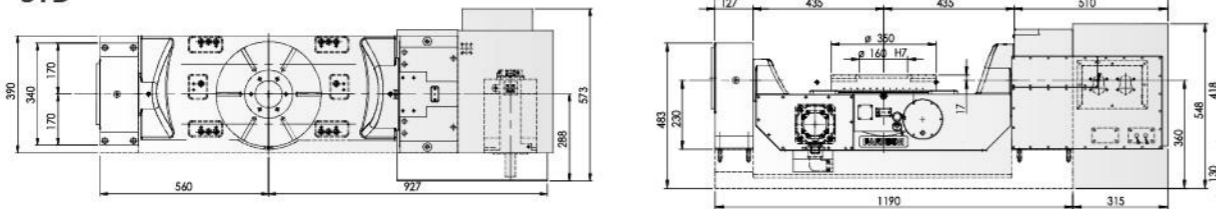

OPT

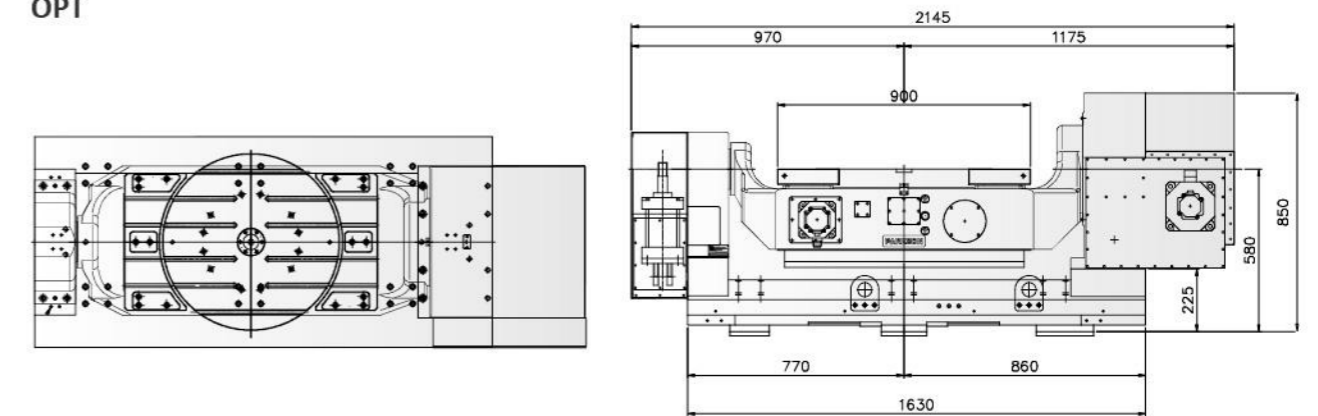

OPT

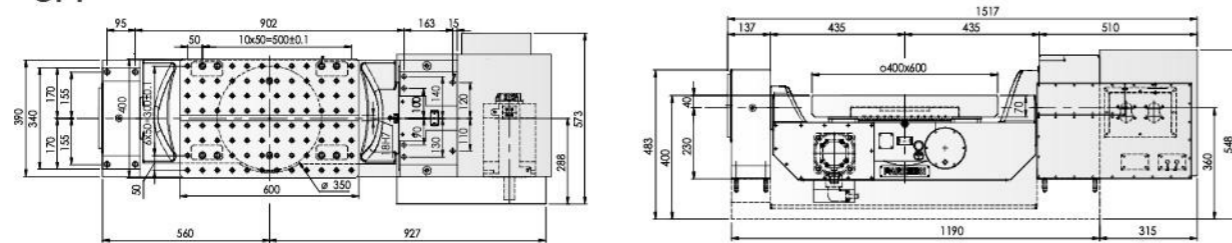

OPT

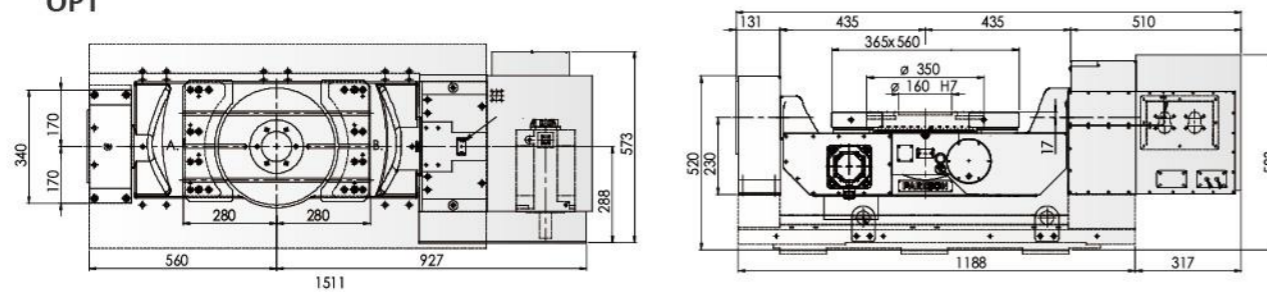

OUTLINE DIMENSION

V-30iT

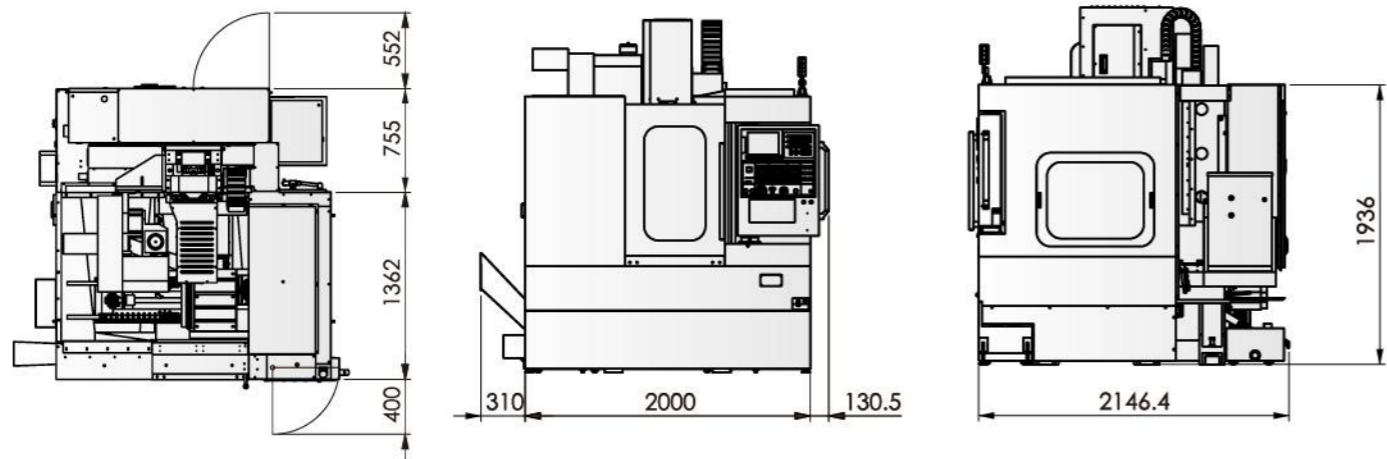

V-32iT

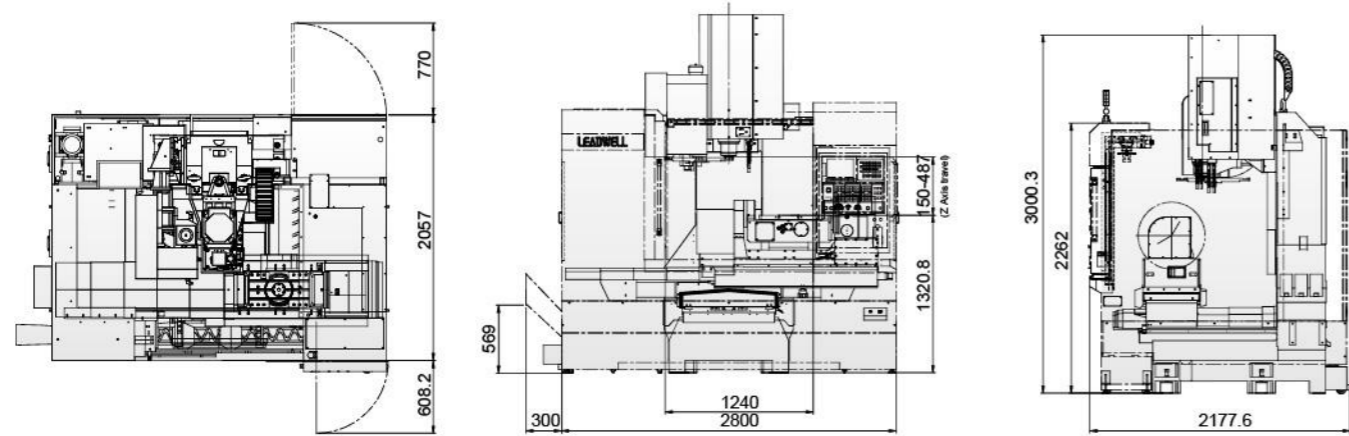

OUTLINE DIMENSION

V-20iT

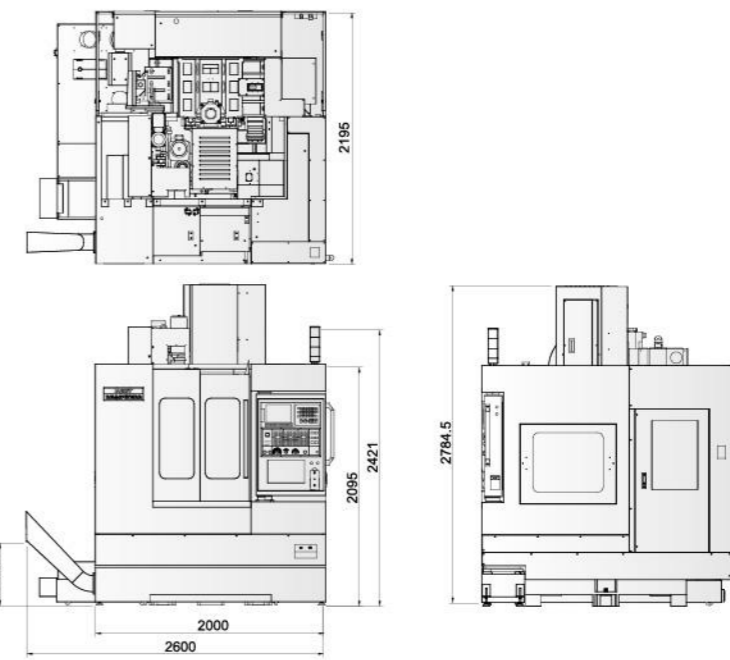

V-40iT

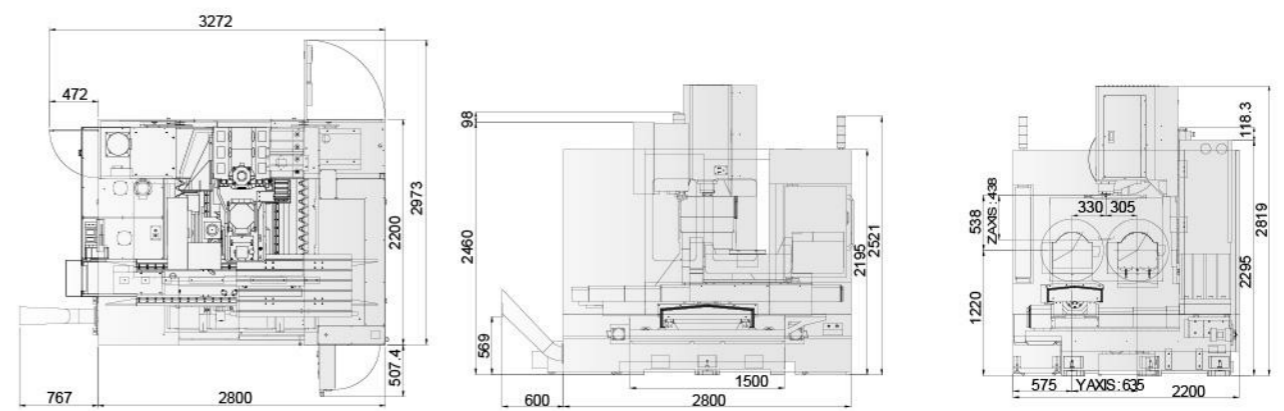

V-60iT

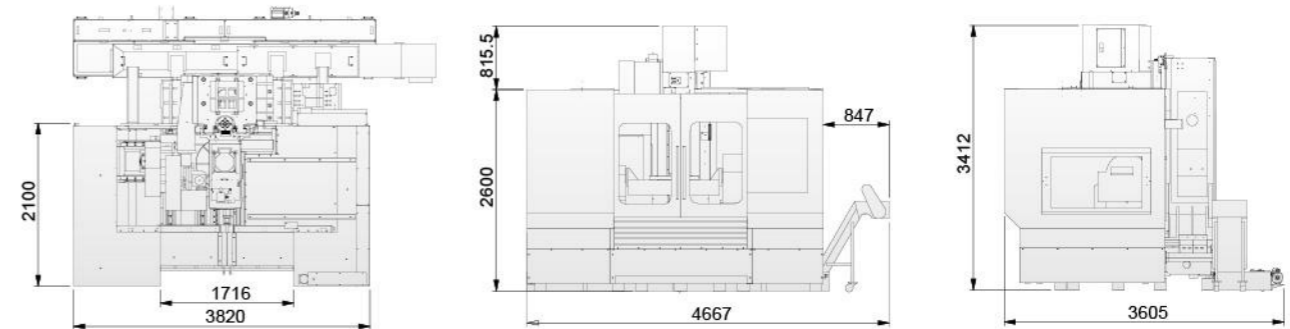

INTERNAL DIMENSION

V-30iT

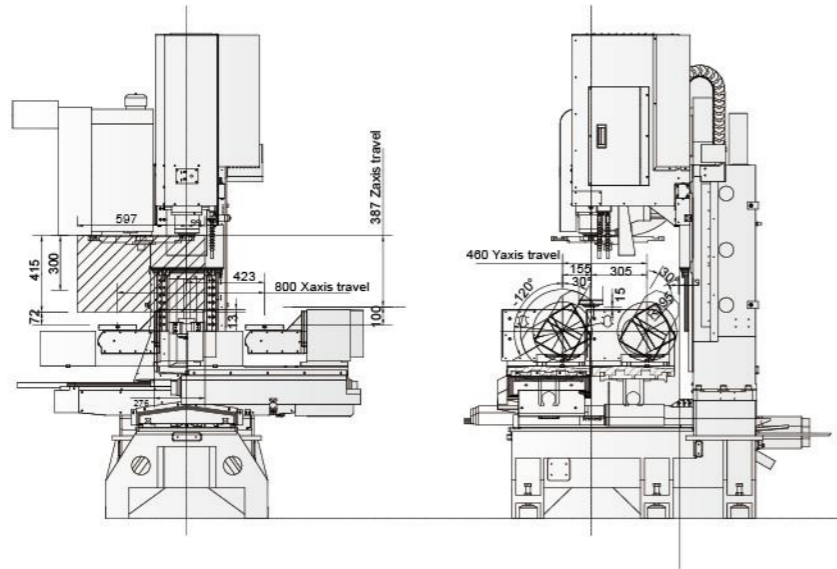

Unit:mm

V-32iT

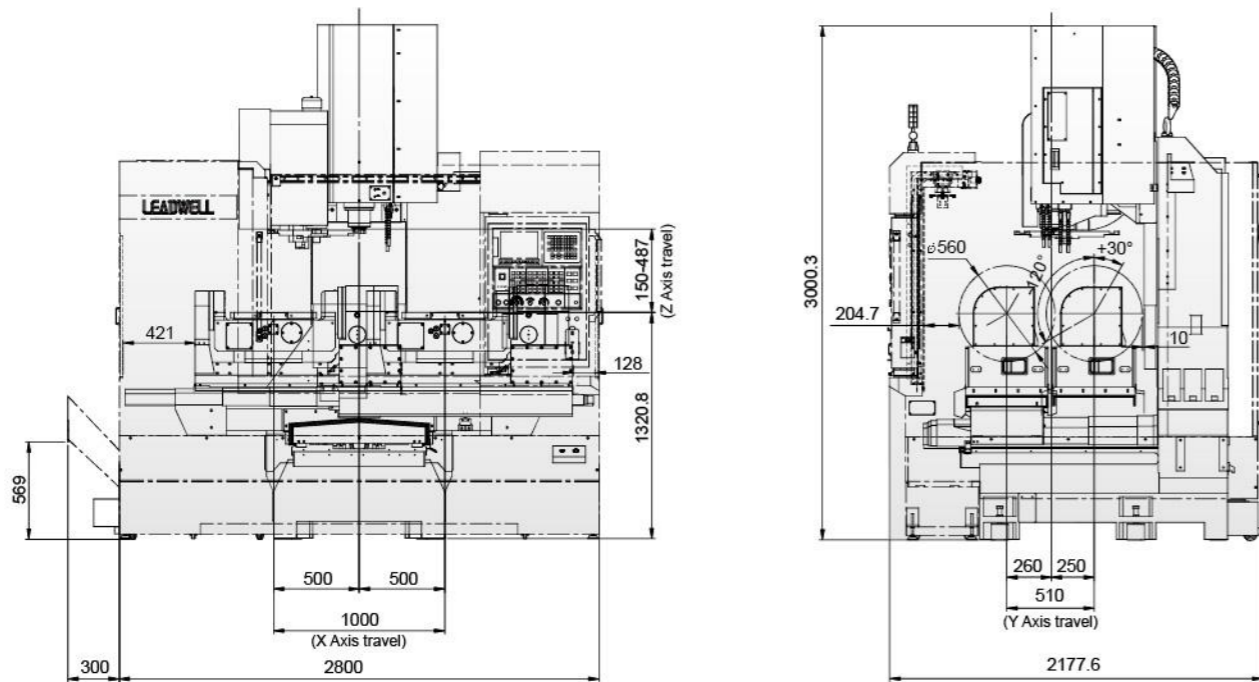

INTERNAL DIMENSION

V-20iT

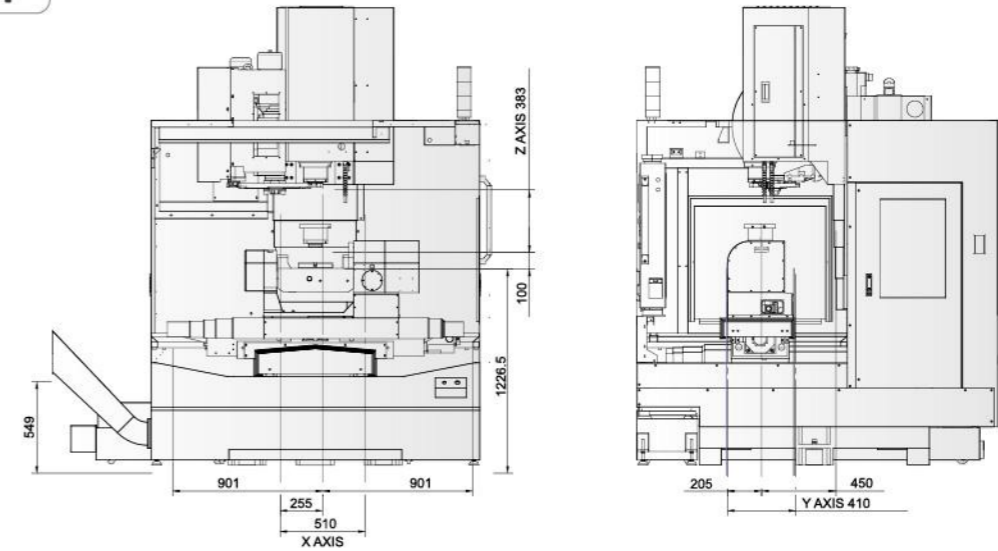

V-40iT

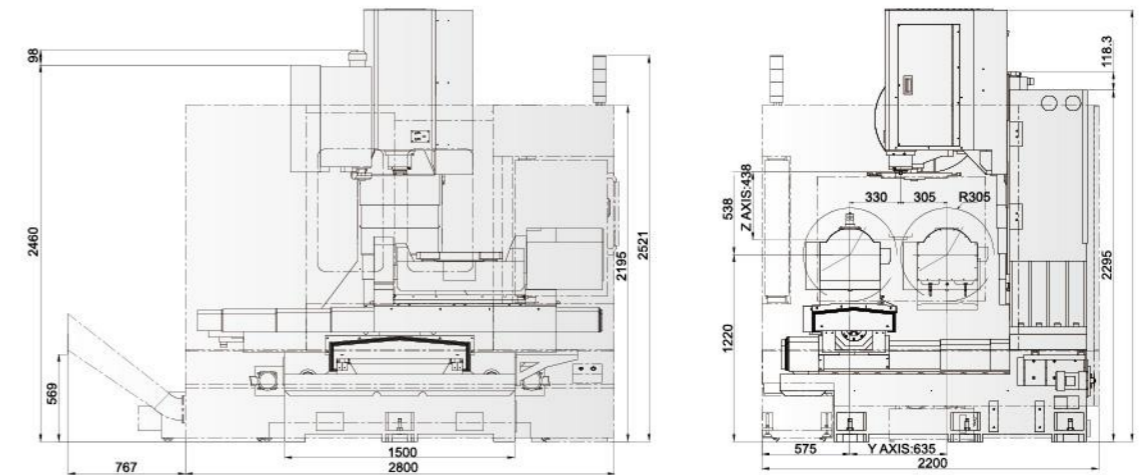

V-60iT

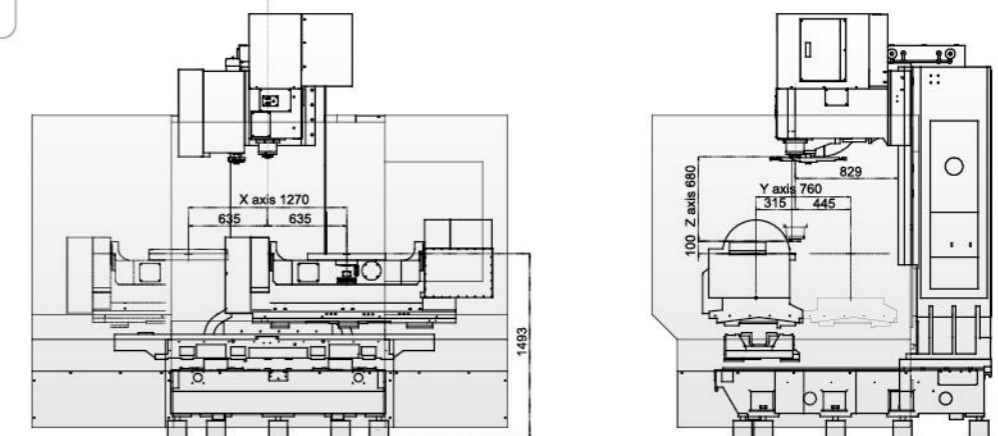

MACHINE SPECIFICATIONS

ITEM	MODEL	V-30iT	V-32iT
A.T.C.	Type	ARM	ARM
CAPACITY	Unit		
X axis travel	mm (in)	800(31.5)	1000(39.4)
Y axis travel	mm (in)	460(18.1)	510(20)
Z axis travel	mm (in)	387(15.2)	337(13)
Table top to spindle end	mm (in)	100-487(3.9-19.1)	150-487(6-19)
Column front to spindle center	mm (in)	508(20)	567(21.5)
TABLE			
Table size (LxW)	mm (in)	φ205(φ8.07)	φ220(φ8.6)
Permissible mass of workpiece	kg	35(0°~45°)/ 25(45°~90°)	100(0°~45°)/ 75(45°~90°)
T-solt size		10	12
SPINDLE			
Spindle speed	rpm	12000	10000
Spindle nose (normal size)	mm	7/24 Taper, NO.40	
Ratios		1:1	1:1
Max.spindle torque	N.M(ft.lbf)	37.7(35.1)	70(51.6)
Transmission		Eagle NRG	H.T.D Belt
FEED RATE			
Rapid traverse	m/min (IPM)	48/48/36(1890/1890/1417)	48/48/36(1890/1890/1417)
Feed rate	m/min (IPM)	10 (394)	10(394)
A.T.C.			
Tooling shank (nominal size,NO.)		BT-40	BT-40
Tool storage capacity		24	24
MOTORS			
Spindle motor (30min)	KW (HP)	11(14.7)	15(20.1)
X-axis feed motor	KW (HP)	4(5.4)	4(5.4)
Y-axis feed motor	KW (HP)	4(5.4)	4(5.4)
Z-axis feed motor	KW (HP)	4(5.4)	4(5.4)
Rotating motor	KW (HP)	0.5(0.67)	1.6(2.1)
Tilting motor	KW (HP)	1.2(1.6)	2.7(3.6)
MISCELLANEOUS			
Positioning accuracy (P) X、Y、Z VDI(3441)	mm	0.01/1000	0.01/1000
Repeatability (PS) X、Y、Z VDI(3441)	mm	0.007/1000	0.007/1000
MACHINE SIZE			
Height of machine (H)	mm(in)	2480(97.6)	3000(118)
Floor space (LxW)	mm(in)	2440x2117(96x83.3)	3100x3432(122x135) FRONT 2800x3639(110x143) REAR
Total machine weight	Kg(lb)	3800(8377)	6500(14330)
Power requirement	KVA	25	30
Controller	FANUC	Oi-M	

*AVAILABLE CONTROLLER: SIEMENS/FAGOR/HEIDENHAIN

MACHINE SPECIFICATIONS

ITEM	MODEL	V-20iT	V-40iT	V-60iT
A.T.C.	Type	ARM	ARM	ARM
CAPACITY	Unit			
X axis travel	mm (in)	510 (20)	846 (33)	1270 (50)
Y axis travel	mm (in)	410 (16)	635 (25)	760(30)
Z axis travel	mm (in)	383 (15)	488(19.2)	680 (26.7)
Table top to spindle end	mm (in)	100-483 (3.9-19)	50-538(1.9-21)	100-780 (3.9-30.7)
Column front to spindle center	mm (in)	450 (17.7)	635 (25)	825 (32.4)
TABLE				
Table size (LxW)	mm (in)	φ210 (φ8.3)	φ350 (φ13.8)	φ630 (φ24.8)
Permissible mass of workpiece	kg	75(0°~45°)/ 50(45°~90°)	200(0°~45°)/ 100(45°~90°)	200(0°~45°)/ 150(45°~90°)
T-solt size		12	12	14H7
SPINDLE				
Spindle speed	rpm	10000	10000	10000
Spindle nose (normal size)	mm	7/24 Taper, NO.40		
Ratios		1:1	1:1	-
Max.spindle torque	N.M(ft.lbf)	70(51.7)	95.4(70.1)	140 (103)
Transmission		H.T.D Belt	H.T.D Belt	H.T.D Belt
FEED RATE				
Rapid traverse	m/min (IPM)	36/36/36 (1417/1417/1417)	36/36/36 (1417/1417/1417)	30/30/20 (1181/1181/787)
Feed rate	m/min (IPM)	10 (394)	10 (394)	5 (196.8)
A.T.C.				
Tooling shank (nominal size,NO.)		BT-40	BT-40	BT-40
Tool storage capacity		24	24	24
MOTORS				
Spindle motor (30min)	KW (HP)	15 (20.1)	18.5 (24.8)	26 (34.9)
X-axis feed motor	KW (HP)	3 (4)	4(5.4)	5.5 (7.3)
Y-axis feed motor	KW (HP)	3 (4)	4(5.4)	6 (8)
Z-axis feed motor	KW (HP)	4 (5.4)	4 (5.4)	5.5 (7.3)
Rotating motor	KW (HP)	1.4 (1.9)	1.6 (2.1)	2.7 (3.6)
Tilting motor	KW (HP)	1.6 (2.1)	4 (5.4)	7 (9.3)
MISCELLANEOUS				
Positioning accuracy (P) X、Y、Z VDI(3441)	mm	0.01/1000	0.01/1000	0.015/1000
Repeatability (PS) X、Y、Z VDI(3441)	mm	0.007/1000	0.007/1000	0.01/1000
MACHINE SIZE				
Height of machine (H)	mm(in)	2620(103.1)	2721(107)	3420 (134.6)
Floor space (LxW)	mm(in)	2700x2140(106.3x84.2)	3840x2200(151.2x86.6)	3820x4365(150x171.8)
Total machine weight	Kg(lb)	5200(11464)	7000(15432)	12500(27500)
Power requirement	KVA	35	35	60
Controller	FANUC	Oi-M		

*AVAILABLE CONTROLLER: SIEMENS/FAGOR/HEIDENHAIN

MACHINE ACCESSORIES

LEADWELL

	V-30iT	V-32iT	V-20iT	V-40iT	V-60iT
Full enclosure guarding	●	●	●	●	●
Chip conveyor (auger type)	●	●	●	●	●
Work light	●	●	●	●	●
Alarm lamp	●	●	●	●	●
Heat exchanger	●	●	●	●	●
Rigid tapping	●	●	●	●	●
Auto counter for work piece	●	●	●	●	●
Remote MPG	●	●	●	●	●
10000rpm spindle	■	●	●	●	●
Spindle oil chiller	●	●	●	●	●
Spindle air purge	●	●	●	●	■
Air conditioner	■	■	■	■	●
Surrounding coolant system	●	■	■	■	■
12000rpm spindle	●	■	■	■	■
15000rpm direct drive spindle with oil	x	■	x	■	■
Tool overload detection	■	■	■	■	■
Linear scale	■	■	■	■	▲
CTS From A & CTS Preparation	■	■	■	■	■
Auto tool length measurement (ATLM)	■	■	■	■	▲
Automatic workpiece measurement	■	■	■	■	▲
Simple tool life management	■	■	■	■	▲
Chip conveyor outside machine & chip bucket	■	■	■	■	■
DNC link software	■	■	■	■	▲
Programmable nozzle	■	■	■	■	▲
Programmable air blow	■	■	■	■	■
Extra coolant tank	■	■	■	■	▲
Spindle annular coolant jet (Arm type ATC)	■	▲	■	■	▲
Oil skimmer	■	■	■	■	▲
Coolant gun	■	■	■	■	■
Through hole drill kit	■	■	■	■	■
Auto door	▲	▲	▲	▲	x
ARM 30T ATC	▲	▲	▲	■	▲
ARM 40T ATC	x	x	x	■	▲
Fluorescent lamp	x	x	x	■	x
Two speed gearbox	x	x	x	x	■
Base wash system	x	x	x	x	■
Shower coolant system	x	x	x	x	▲
Oil mist collector	x	x	x	x	▲

●:STD / ■:OPT(DESIGNED) / ▲:OPT(TO BE ADVISED) / x:N/A(NOT AVAILABLE)
