



VL-400C
CNC vertical turning

• VL-300~600C/CM



• VL-160~600C/CM-2R

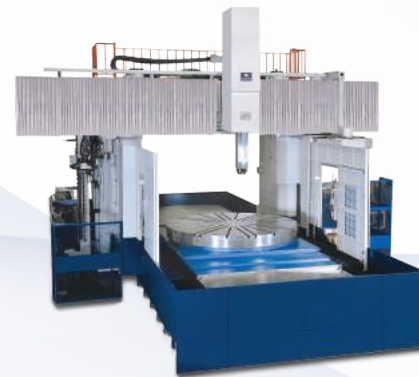

• PL-160~500CM



• VG-160CMG



• VL-66~250C/CM



• VL-46~100A/M/H



• HL-26/32AT



• VG-120~250GN/GB



• VL-66KA2

High Precision / High Efficiency
High Durability / Perfection



YES! WE ARE HONOR!



VL-66
VL-86
VL-100



 **HONOR SEIKI Co., Ltd.**

No. 6, Sec. 2, Chungshan Rd., Hunei Dist., Kaohsiung City, 82942 Taiwan
TEL : +886 7 975 9888 / FAX : +886 7 975 9999
e-mail : honor@honorseiki.com http : //www.honorseiki.com



Agent :

[Empty box for agent information]

201708 2000

Heavy Duty Series

CNC Vertical Lathe / CNC Vertical Turning Center

 **HONOR SEIKI Co., Ltd.**

www.honorseiki.com



Fields Of Application

Vertical Lathe & Vertical Turning Center

- Construction
- Automotive
- Aerospace
- Rail
- Boat
- Bearing
- Valve
- Mold
- Gear
- Machine tool
- Power plant
- Oil & gas
- Wind power



• Thousands Of Successful Turnkey



Machine Structure

• Customize tool clamping system



▪ GC clamping system



▪ BT50 clamping system



▪ Solid Lock clamping system (U.S. patent of invention by HonorSeiki)



• Stable column design

- One piece column with wide span.
- Box structure of column reduce vibration.
- Available for VL-100CR/VL-100CRM only.

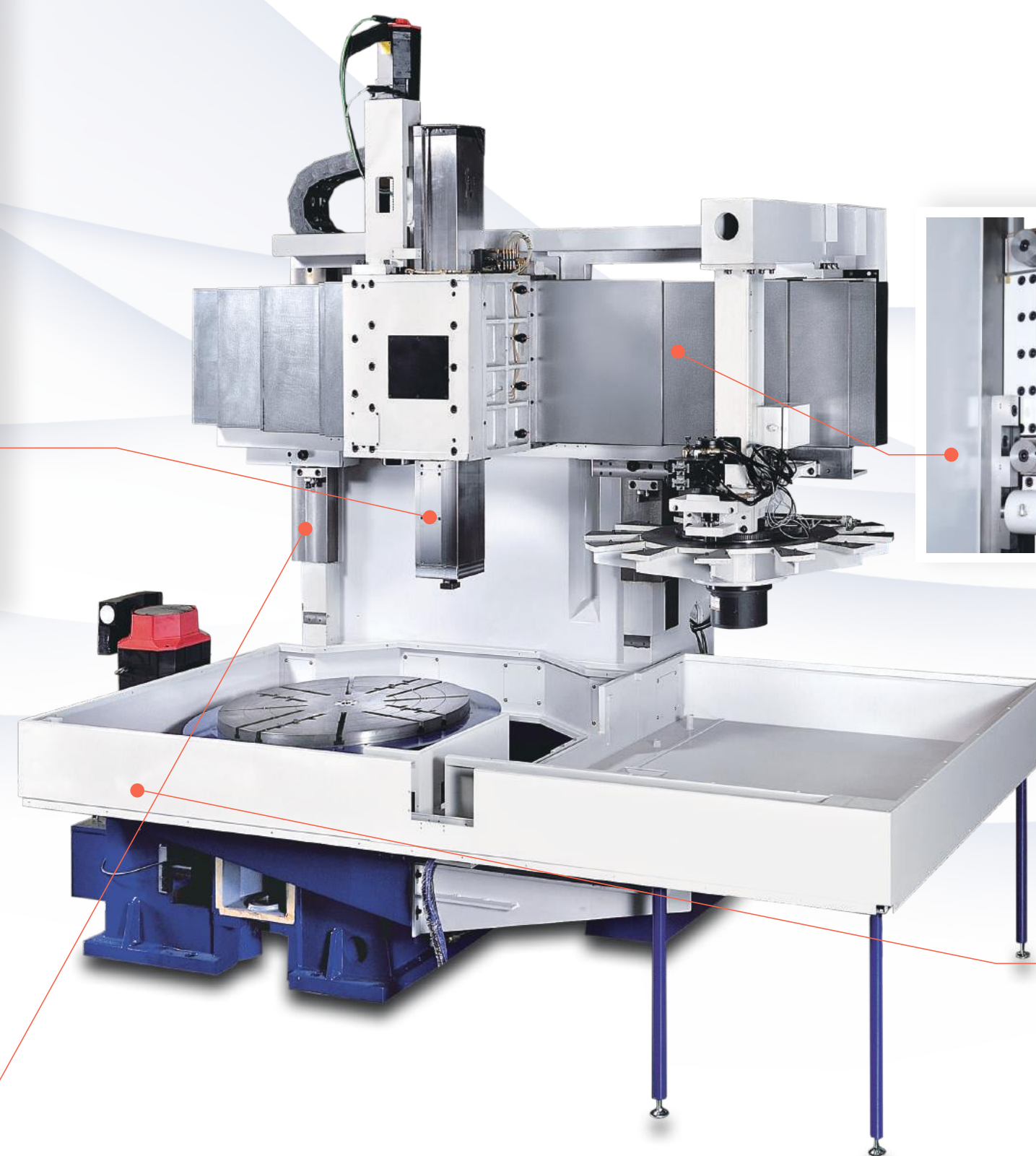

• Positioning lock for the stability of cross-rail.

- Cross-rail ensures parallelism and stability by positioning lock with clamping.
- Available for VL-100CR/VL-100CRM only.



• Gearbox.

- One-piece big machine bed with bulid-in gearbox and spindle.

(Photo : VL-100CR)

C-TYPE ATC

(Turning)

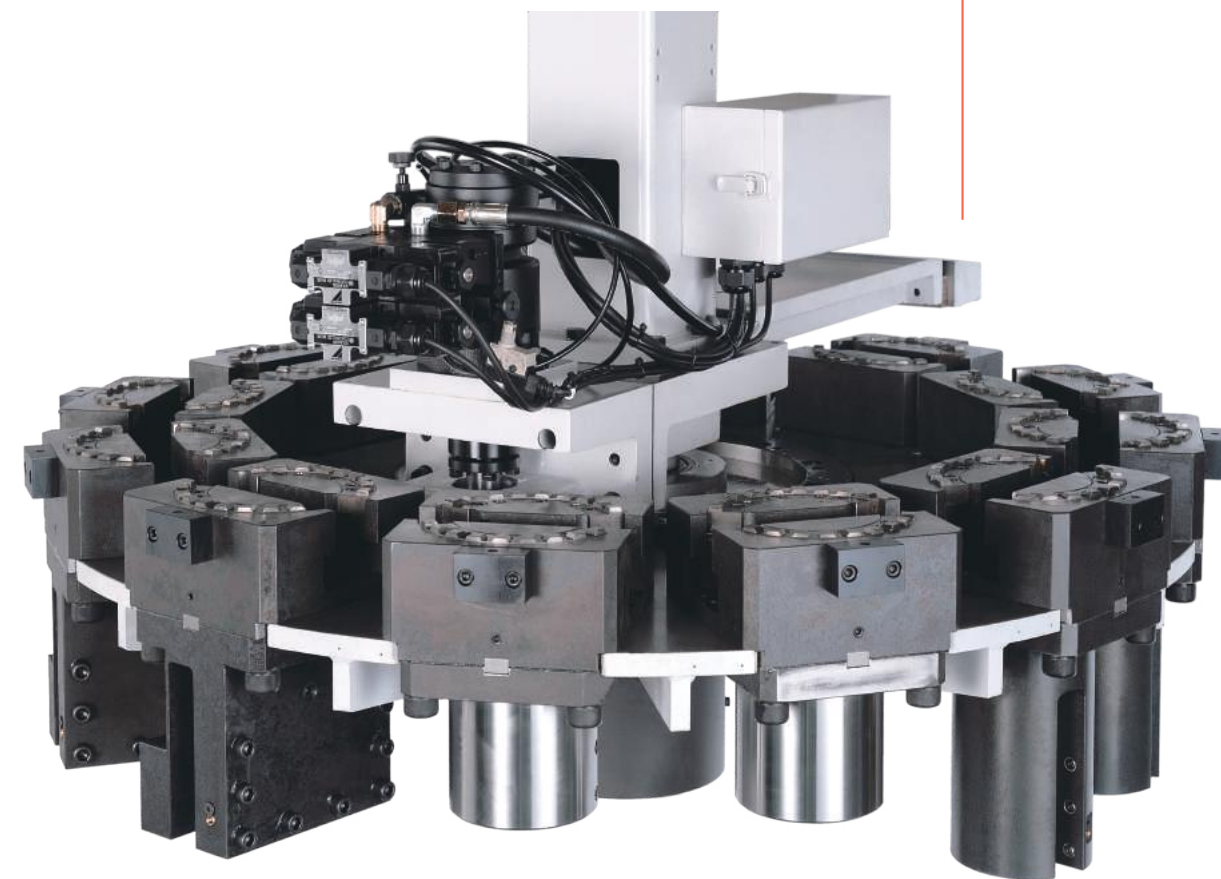

• GC-200 (Gear Coupling)

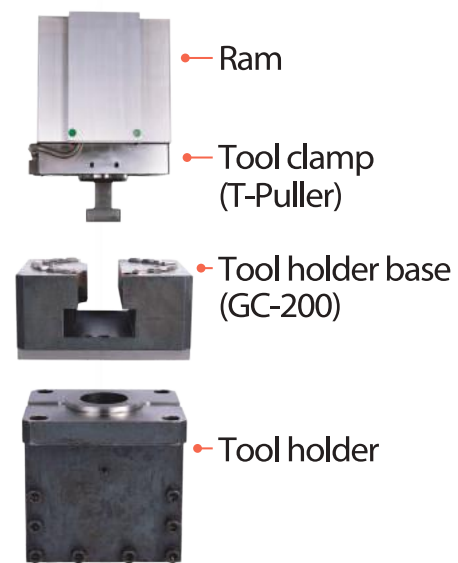

• PC17T (Option) (Two Face Contact Tooling / Patent)

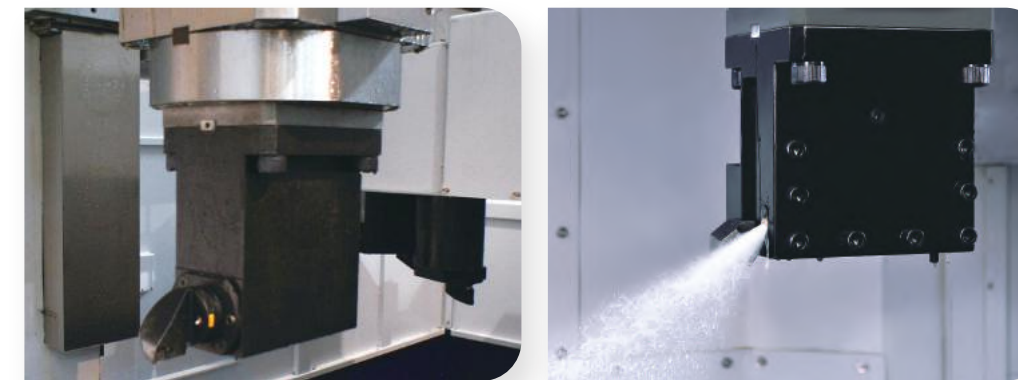

C-Type ATC Tool System

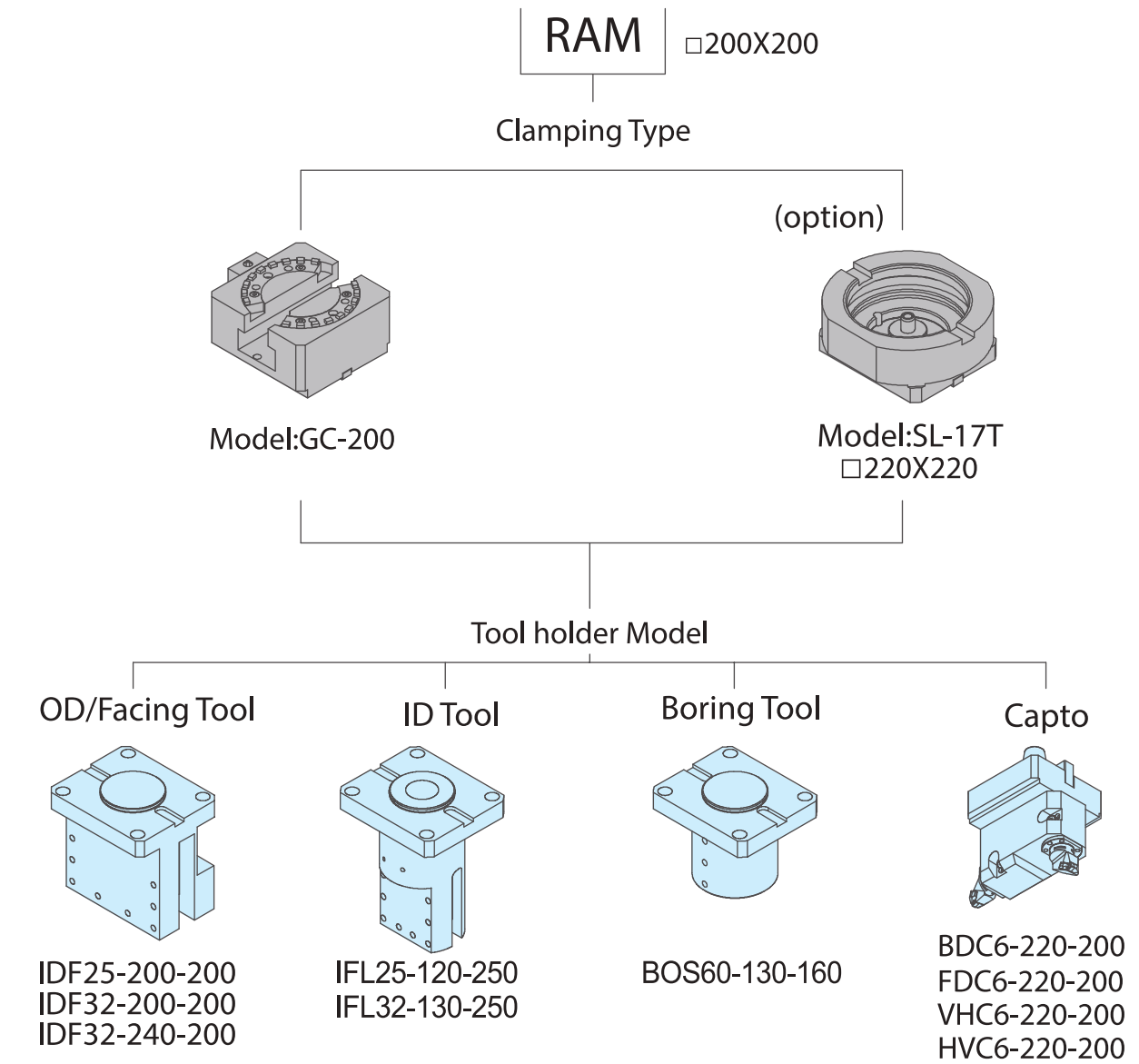

M-TYPE ATC

(Turning and milling)

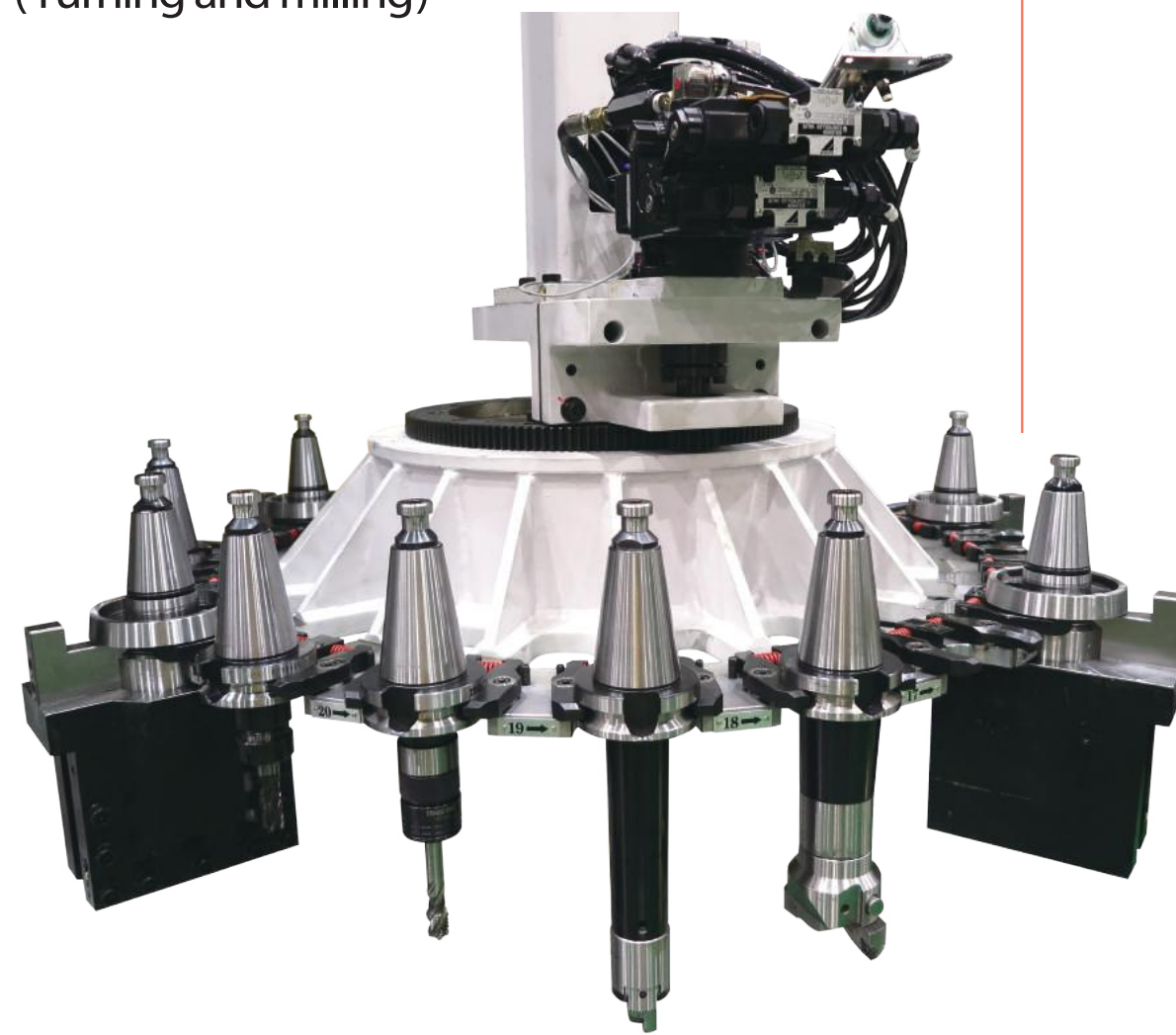

• BT50-200 (BT50)

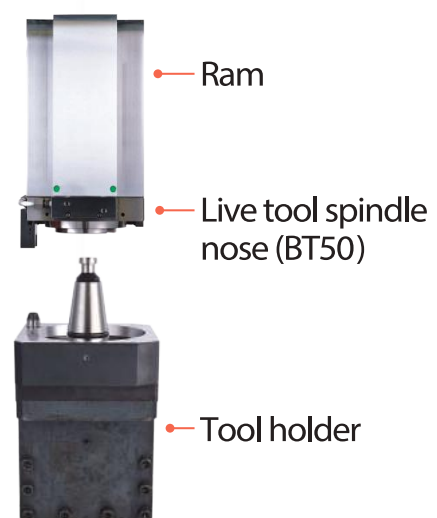

M-Type ATC Tool System

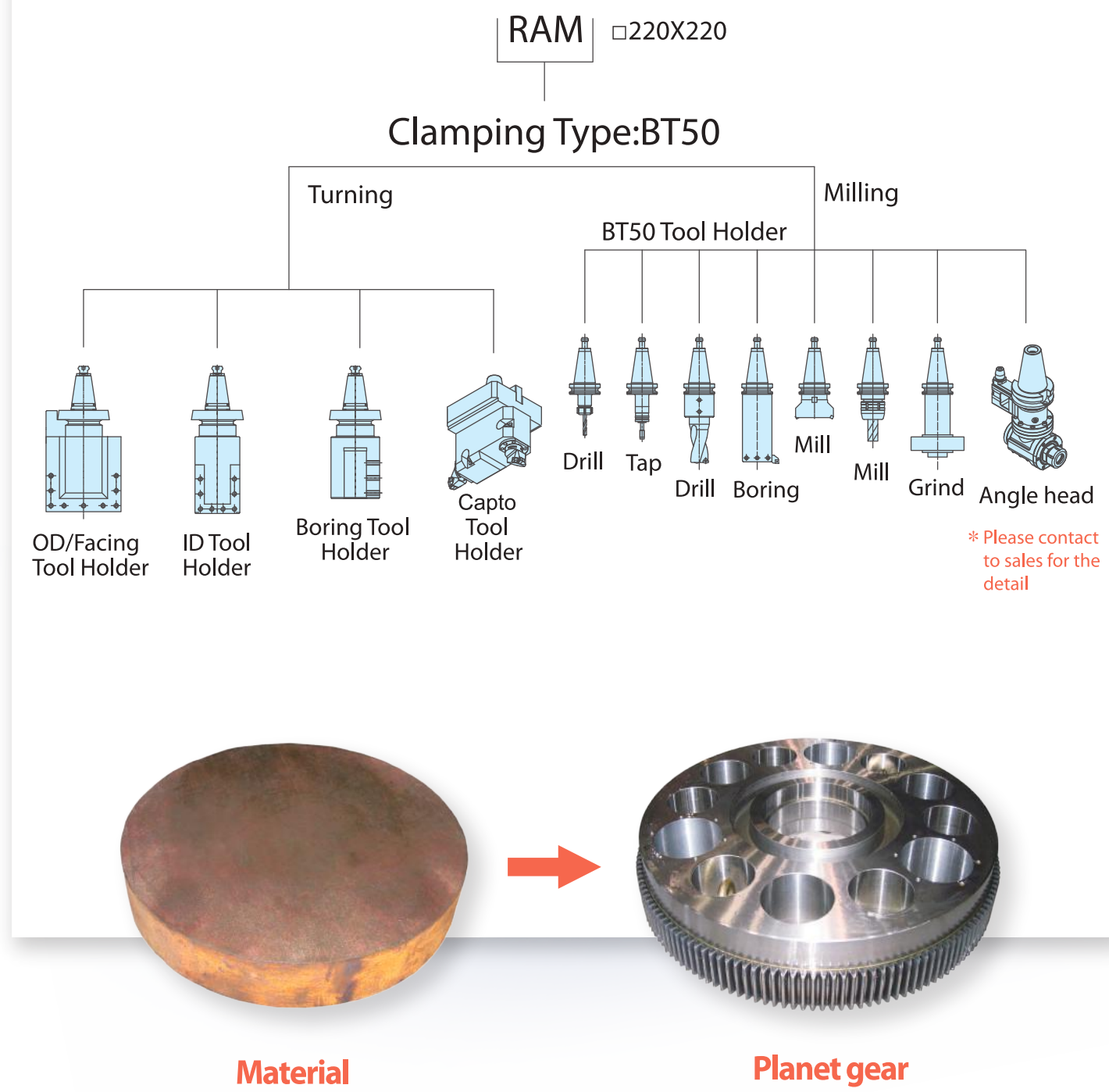

M-TYPE ATC (Solid Lock) (Turning and milling)

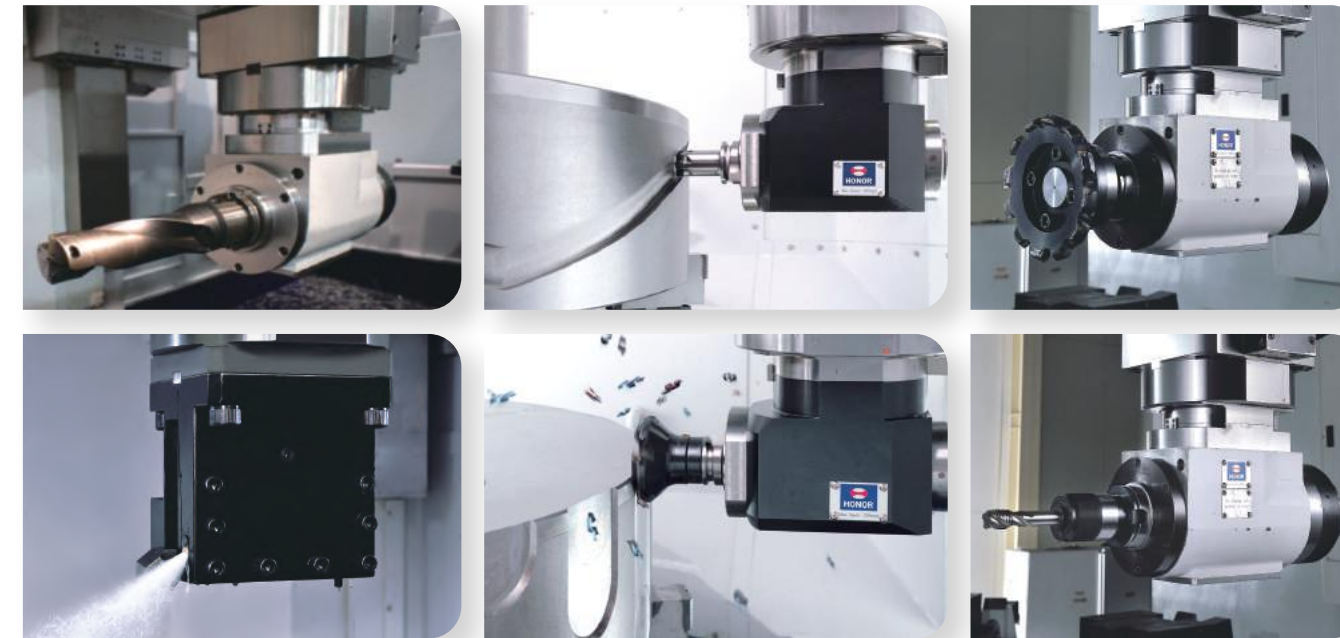
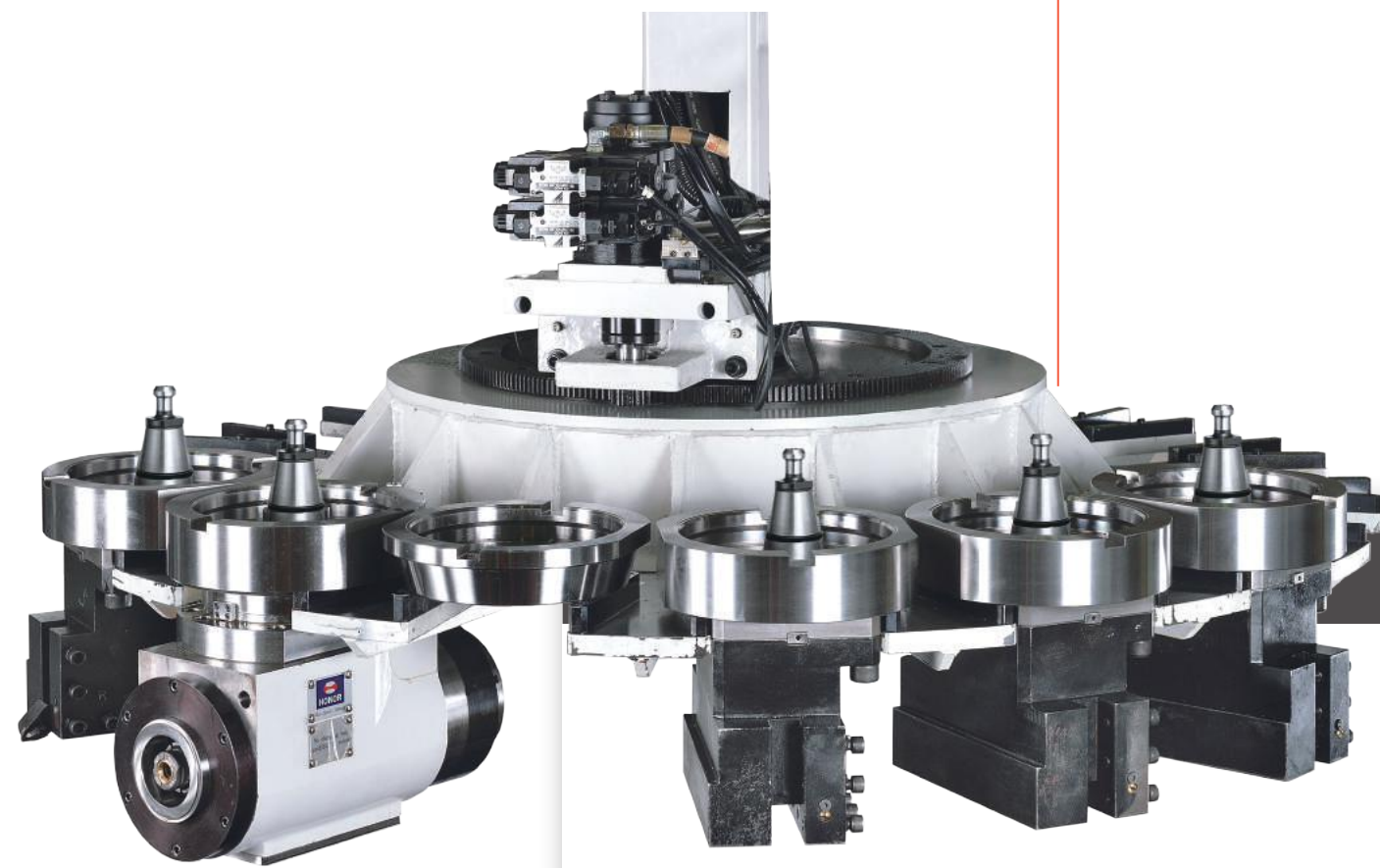

Solid-lock ATC Tool System(option)

• PC17A (Two Face Contact Tooling / Patent)



Clamping Type:

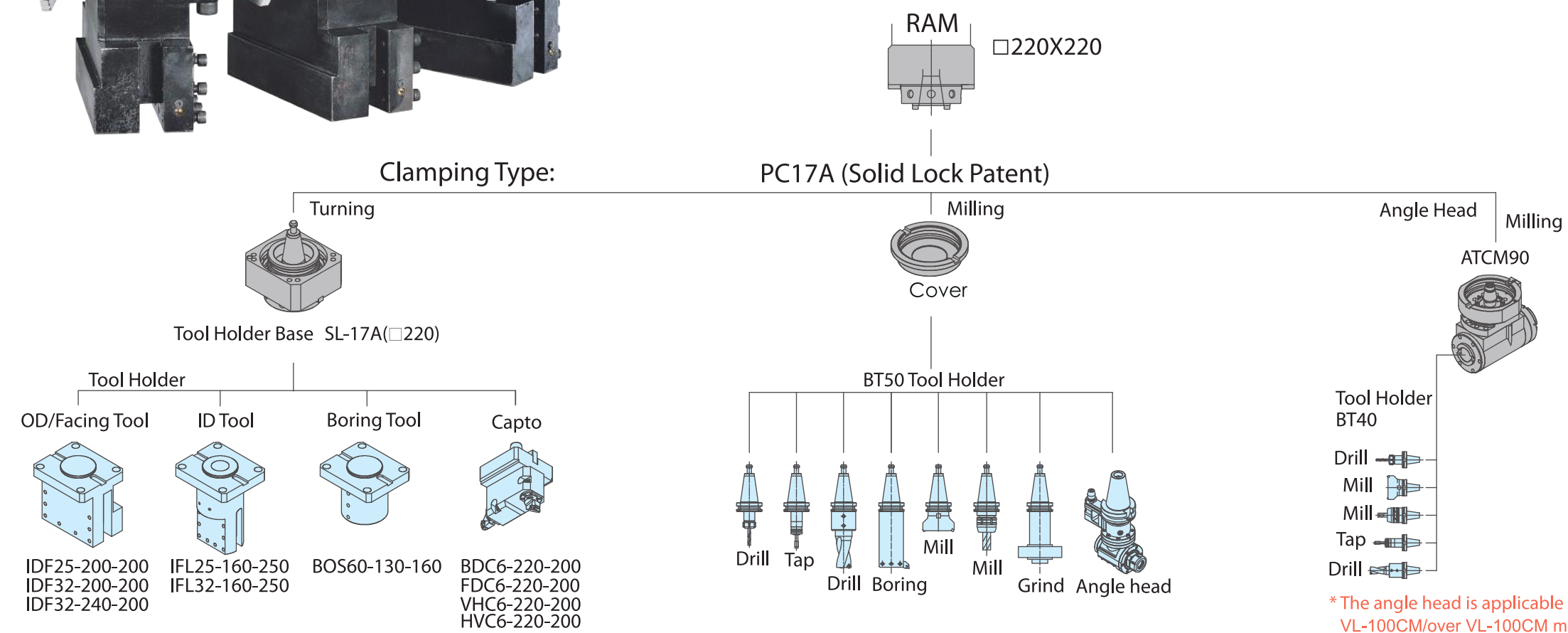

- IDF25-200-200
- IDF32-200-200
- IDF32-240-200
- IFL25-160-250
- IFL32-160-250
- BOS60-130-160
- BDC6-220-200
- FDC6-220-200
- VHC6-220-200
- HVC6-220-200

* The angle head is applicable to VL-100CM/over VL-100CM model. VL-66/VL-86 model is inappropriate.

Tool Holder System

■ Tool holder base :

GC-200 (□200 / □220)
(Gear Coupling)

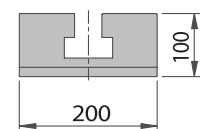

SL-17T (□220)
(Two face contact tooling)

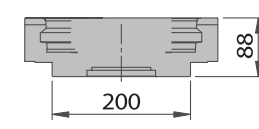

SL-17A (□220)
(Two face contact tooling)

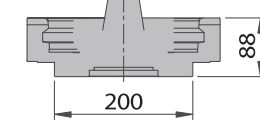

(unit:mm)

■ GC-200 / SL-17T / SL-17A Tool holder :

O.D. / Facing tool holder

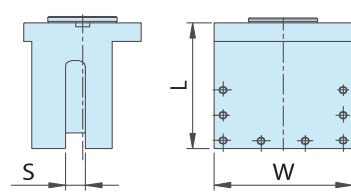

Model	L	S	W
IDF25-200-200	200	25	200
IDF32-200-200	200	32	200
IDF32-240-200 *	200	32	240

I.D. / Facing tool holder

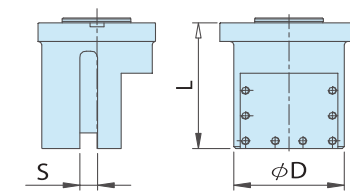

Model	L	S	φD
IFL25-160-250	250	25	120
IFL32-160-250	250	32	130

Boring tool holder

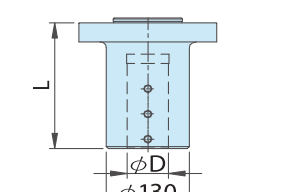

Model	L	φD
BOS60-130-160	160	60

* : Only for SL-17A

■ Capto Tool holder :

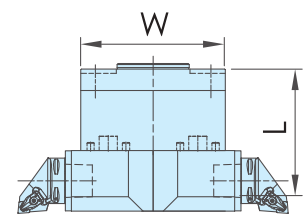

Model	L	W
BDC6-220-200	200	220

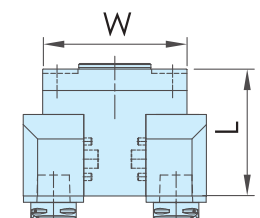

Model	L	W
FDC6-220-200	200	220

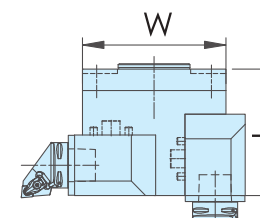

Model	L	W
VHC6-220-200	200	220

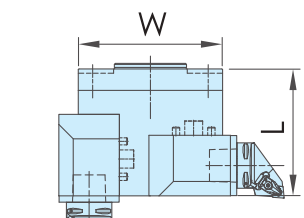

Model	L	W
HVC6-220-200	200	220

■ BT-50 Tool holder :

O.D. / Facing tool holder

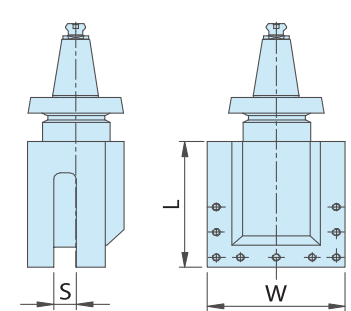

Model	L	S	W
BT50-IDF25-200-200	200	25	200
BT50-IDF32-200-200	200	32	200

I.D. / Facing tool holder

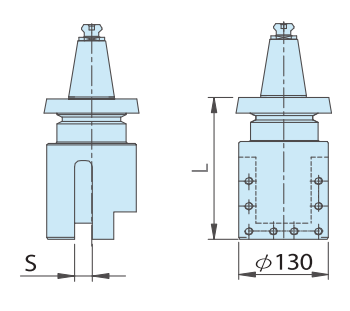

Model	L	S
BT50-IFL25-130-200	200	25
BT50-IFL32-130-200	200	32

Boring tool holder

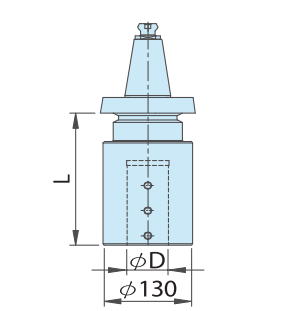

Model	L	φD
BT50-BOS40-130-200	200	40
BT50-BOS50-130-200	200	50
BT50-BOS60-130-200	200	60

Machine Dimensions

■ VL-66 / VL-86 series

(unit:mm)

	A	B	C	∅D	E	F	G	H
VL-66C	1150	4700	3600	∅610	2450	1065	3450	920
VL-66CM	1150	4800	3600	∅610	2450	1065	3450	920
VL-86C	1150	4700	3600	∅800	2450	1065	3450	920
VL-86CM	1150	4800	3600	∅800	2450	1065	3450	920

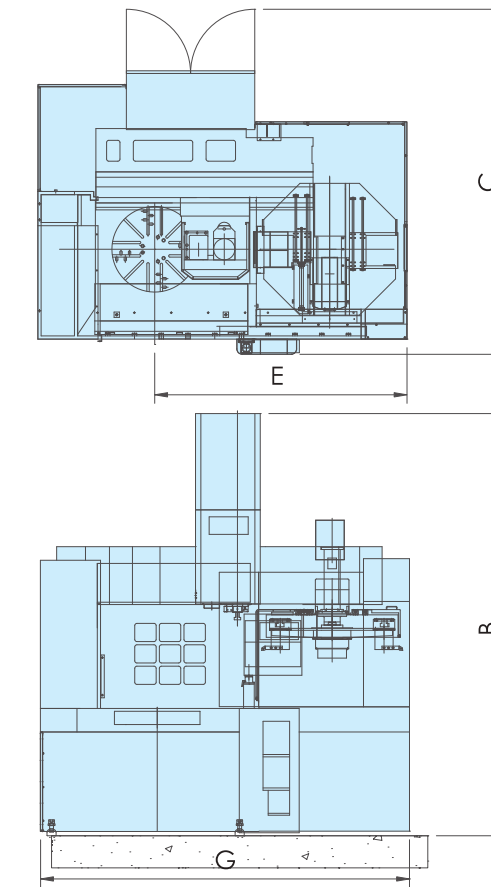
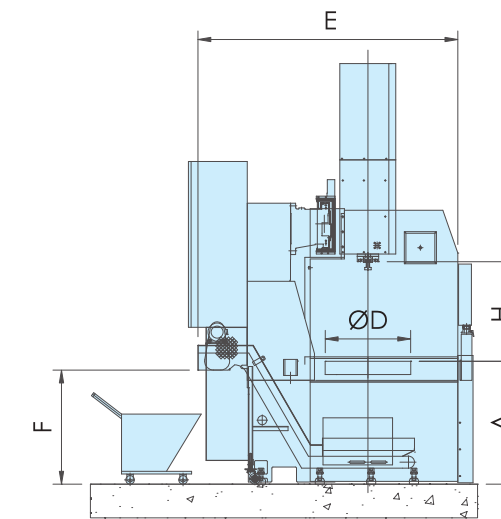

■ VL-100 series

(unit:mm)

	A	B	C	∅D	E	F	G	H
VL-100C	990	4200	4020	∅1000	2735	1000	4060	925
VL-100CM	1025	4850	4020	∅1000	2735	1000	4060	925
VL-100CR	990	4300	4020	∅1000	2735	1000	4060	500-1100
VL-100CRM	1025	5000	4020	∅1000	2735	1000	4060	500-1100

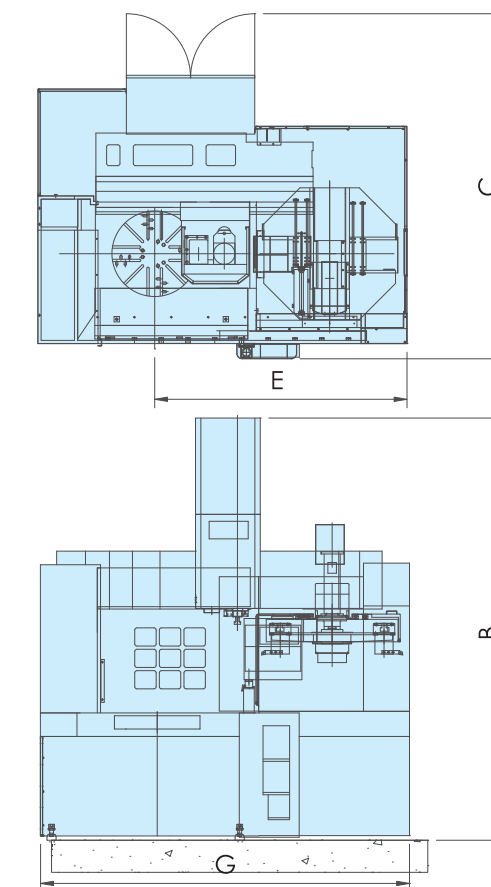
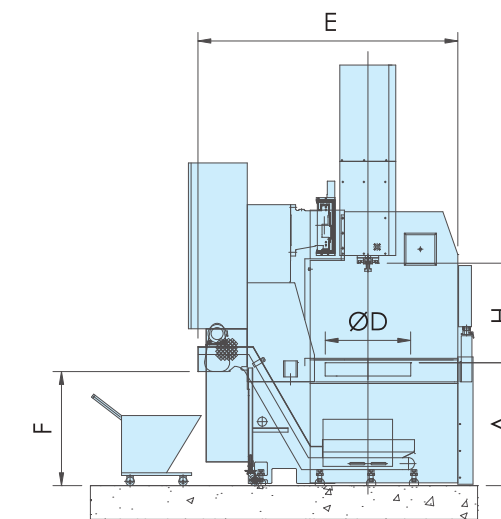

Option

<p>• Hydraulic chuck</p> 	<p>• Linear encoder</p> 	<p>• Thermal compensation</p> 
<p>• Magnetic chuck</p> 	<p>• Second control box</p> 	<p>• Paper type filter</p> 
<p>• Tool presetter</p> 	<p>• Touch probe (workpiece inspection)</p> 	<p>• Siemens controller</p> 
<p>• Full enclose splash guard</p> 	<p>• Oil skimmer (disk)</p> 	<p>• Air conditioner for electrical cabinet</p> 

Table Speed, Torque, Output Chart

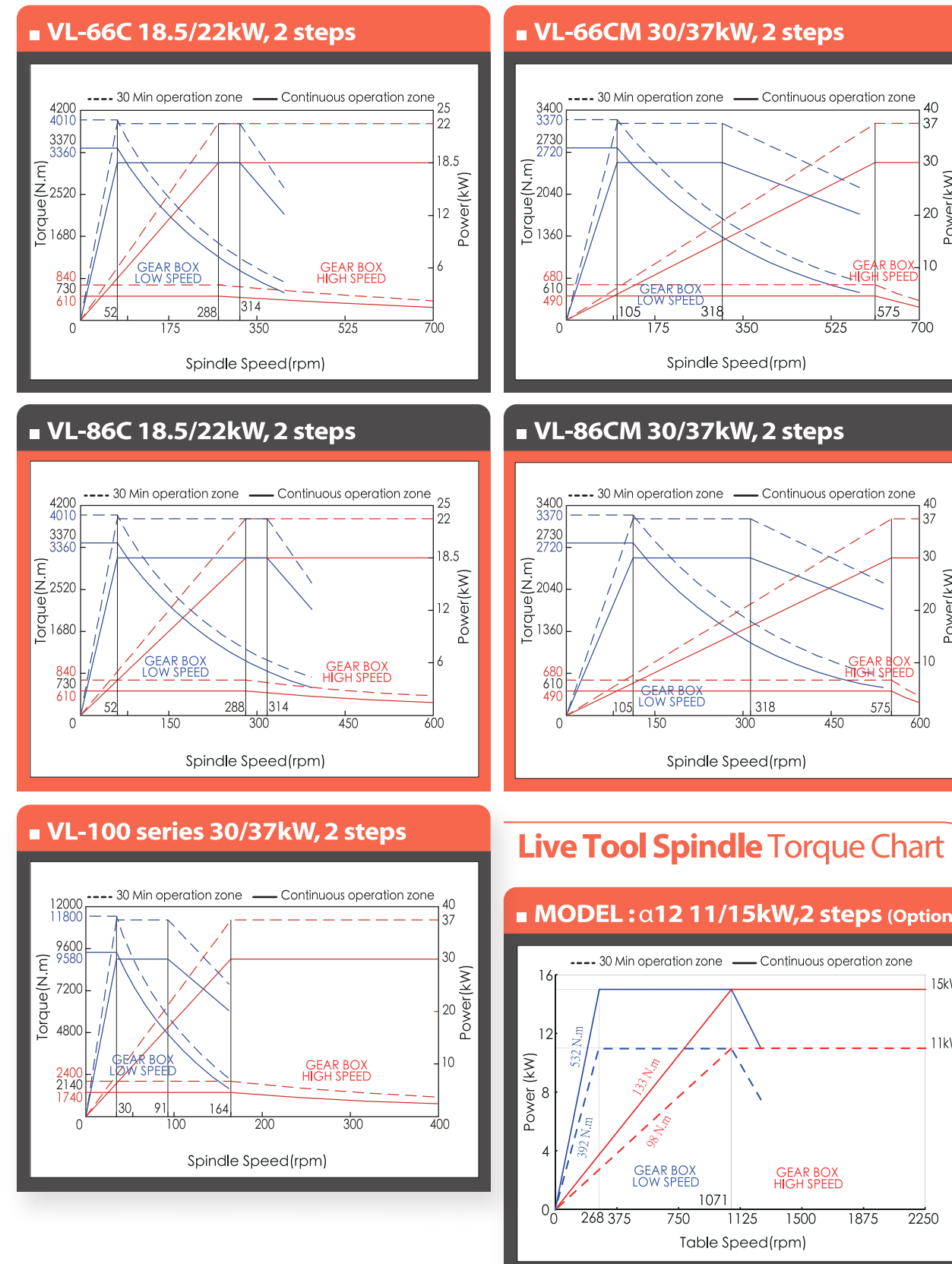

Manual Table Dimensions

VL-86 Series

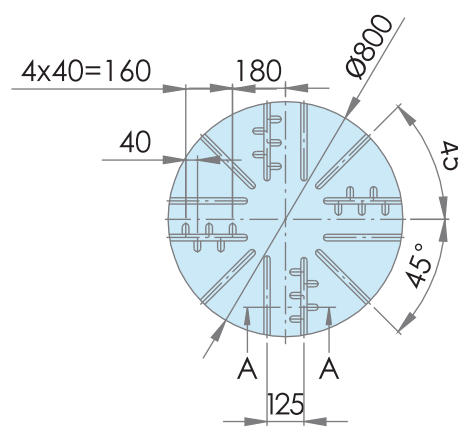

VL-100 Series

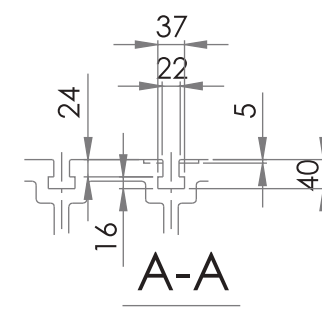
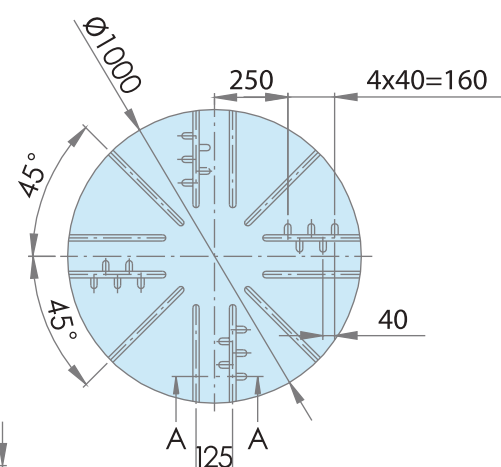

(unit:mm)

Workpiece Clamping

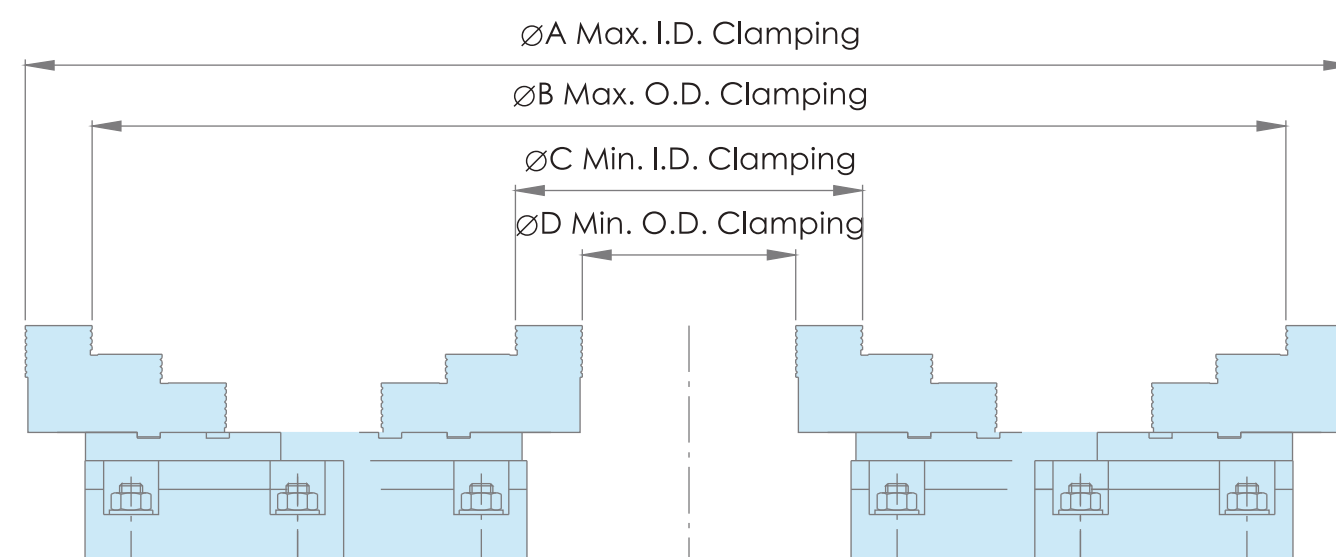

(unit:mm)

Model	A	B	C	D
VL-86C / VL-86CM	1150	900	160	50
VL-100C / VL-100CM	1150	1040	300	190

Working Area And Tool interference

Min. inner diameter of turning

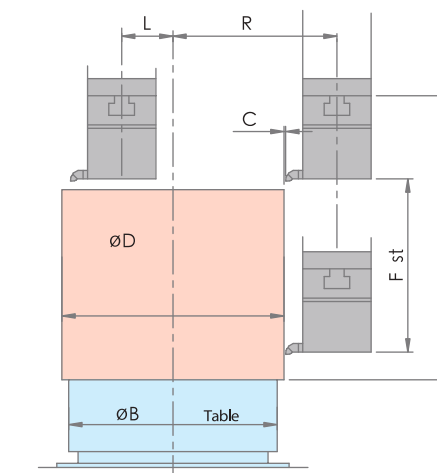
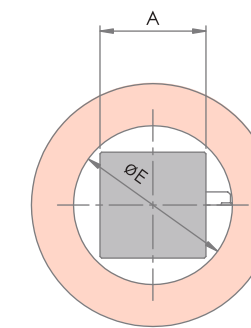

(unit:mm)

Model	A	ØB	C	ØD	ØE	F	G	R	L
VL-66C	200	610	10	800	300	600	925	650	100
VL-66CM	220	610	10	800	330	600	925	650	100
VL-86C	200	800	15	900	300	600	925	750	100
VL-86CM	220	800	15	900	330	600	925	750	100
VL-100C	200	1000	20	1200	300	700	925	750	100
VL-100CM	220	1000	20	1200	330	700	925	750	100
VL-100CR	200	1000	20	1200	300	700	(500-1100)	750	100
VL-100CRM	220	1000	20	1200	330	700	(500-1100)	750	100

Jaws Dimensions

F Type

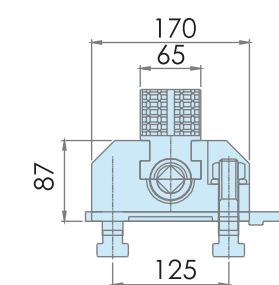
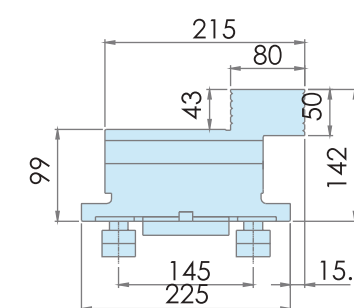

C Type (Standard)

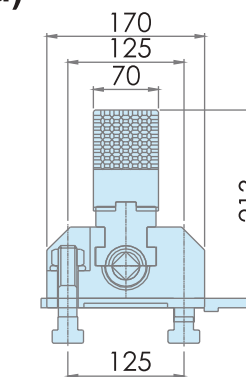
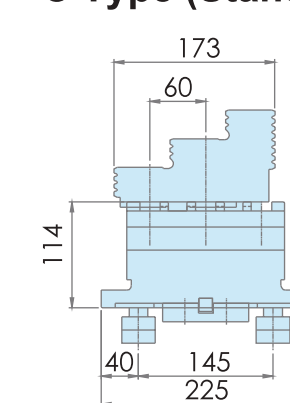

(unit:mm)

Machine Specifications

Model/Description	Unit	VL-66C	VL-66CM	VL-86C	VL-86CM	VL-100C	VL-100CM	VL-100CR	VL-100CRM	
Capacity	Max. swing diameter	mm	850		950		1200		1200	
	Max. turning diameter	mm	850		950		1200		1200	
	Distance from ram to table	mm	925		925		925		500-1100	
	Max. turning height	mm	650		650		650		800	
	Max. workpiece weight	kg	1500		2000		3500		3500	
Spindle	Table diameter	mm	610		800		1000		1000	
	Range of table speed	rpm	1-700		1-600		1-400		1-400	
	Change gear speed		2-step		2-step		2-step		2-step	
	Spindle nose	mm	A2-11		A2-11		-		-	
	Tool live spindle speed	rpm	-	50-2250	-	50-2250	-	50-2250	-	50-2250
ATC	ATC(Automatic Tool Change)		12		12		12		12	
	Tool size	mm	□25, □32		□25, □33		□25, □32		□25, □32	
	Cross-section of ram	mm	200x200	220x220	200x200	220x220	200x200	220x220	200x200	220x220
Feed	Rapid rate (X-Axis)	m/min	10		10		10		10	
	Rapid rate (Z-Axis)	m/min	10		10		10		10	
	Horizontal travel(X-Axis)	mm	-100+650		-100+750		-100+750		-100+750	
	Vertical travel (Z-Axis)	mm	600		600		700		700	
	Cutting feed rate	mm/min	1-5000		1-5000		1-5000		1-5000	
	Feed override	%	0-150		0-150		0-150		0-150	
	Cross-rail travel	mm	Fixed		Fixed		Fixed		200x3 step	
Motor	Control System		Fanuc 0i-T		Fanuc 0i-T		Fanuc 0i-T		Fanuc 0i-T	
	Spindle motor (Cont./30min)	kW	18.5/22	30/37	18.5/22	30/37	30/37		30/37	
	Feed motor(X/Z axis)	kW	4.0/4.0		4.0/4.0		4.0/4.0		4.0/4.0	
	Live tool motor	kW	-	11/15	-	11/15	-	11/15	-	11/15
Machine size	Power requirement	kVA	40	55	40	55	75	90	75	90
	Floor space(LxW)	mm	4700x4800		4700x4800		4200x4850		4300x5000	
	Max. height(H)	mm	4500		4500		4000		4550	
Net weight	kg	12500		13500		17800		18600		
									18300	19100

*The specifications are subject to change without notice.

NOTE

.....

.....

.....

.....

.....

.....

.....

.....

.....

.....

Standard accessories

- Complete splash guard.
- Hydraulic 3-jaw solid chuck & cylinder, size as spec. (VL-66/VL-86)
- Hydraulic chuck soft jaw x 1 set.(VL-66)/(VL-86)
- Foot switch for hydraulic chuck.(VL-66)/(VL-86)
- Table with manual 4-jaw chuck as spec.(VL-100)
- Hydraulic power unit.
- Protection door.
- Automatic lubrication system.
- Working light.
- Warning light.(R/Y/G)
- Workpiece counter.(CNC controller)
- Coolant system with tank.
- Coolant bed wash down system.
- Heat exchanger for electrical cabinet.
- Hand tool set with tool box.
- Leveling bolts & seat pads.
- Chip conveyor.(Hinge type)
- Chip trolley.
- Spindle orientation.
- VL-100C, 100CM fixed type crossrail.
- Manual of operation & maintenance.
- Manual of electrical & hydraulic circuit diagram.

Optional accessories

- Hydraulic chuck & cylinder, size selections.
- Higher power motor.
- Air conditioner for electrical cabinet.
- Table with manual 4-jaw chuck as spec. (VL-66/VL-86)
- Power transformer.(external)
- Oil skimmer.(Disk type)
- Tool holder base.
- Other tool holder & special tool holder.
- Tool presetter.
- Linear encoder of X/Z axis.
- High & low pressure chucking.
- Lubricant chiller for spindle bearing & gear.
- Extend vertical travel.(Z axis)
- Hard jaw for hydraulic chuck.
- High pressure coolant through tool holder.
- Dual gear box for live tool spindle.
- Chip conveyor, scraper type.
- Manual guide i .
- CE certificate.
- Tooling.
- Jig & fixture.
- Turnkey project.
- Siemens controller.

NOTE

.....

.....

.....

.....

.....

.....

.....

.....

.....

.....