



• VL-300~600C/CM



• VL-160~600C/CM-2R



• VL-66~250C/CM



• VL-46~100A/M/H



• HL-26/32AT

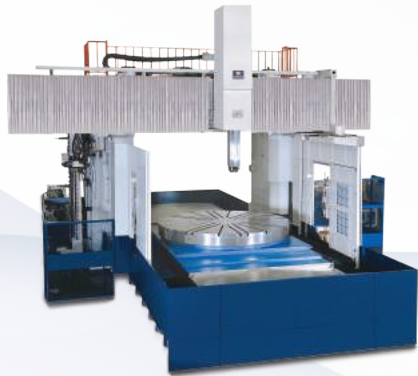

• PL-160~500CM



• VG-160CMG



• VG-120~250GN/GB



• VL-66KA2

High Precision / High Efficiency
High Durability / Perfection



YES! WE ARE HONOR!



VL-46
VL-66
VL-86
VL-100
HL-32AT

**High
Speed**



HONOR SEIKI Co., Ltd.

No. 6, Sec. 2, Chungshan Rd., Hunei Dist., Kaohsiung City, 82942 Taiwan
TEL : +886 7 975 9888 / FAX : +886 7 975 9999
e-mail : honor@honorseiki.com http : //www.honorseiki.com



CNC Vertical Lathe / CNC Vertical Turning Center

HONOR SEIKI Co., Ltd.

www.honorseiki.com



Agent :

The Expert Of

Vertical Lathe & Vertical Turning Center

A long industrial production line of vertical turning centers (VTL) with orange robotic arms. The machines are arranged in a long row, and the robotic arms are positioned over the worktables. The scene is brightly lit, and the overall atmosphere is clean and modern.

VTL production line with robot

Thousands Of Successful Turnkey



Machine Structure

- High flexibility for production arrangement.
- L / R spindle are available.
- Easy for robot connection.



Electrical cabinet

- Easy maintenance circuit arrangement.
- Suitable for all kinds of environment.



Turret

- H12 turret with strong clamping force and gear curvic coupling that provides high tool changing accuracy and cutting force.
- Full cover guarding keeps chips away.
- Vertical type turret, Gang type turret, and Milling type turret are available.



High / Low hydraulic pressure

- Easy access to hydraulic control system.
- Optional High/Low chuck clamping pressure.

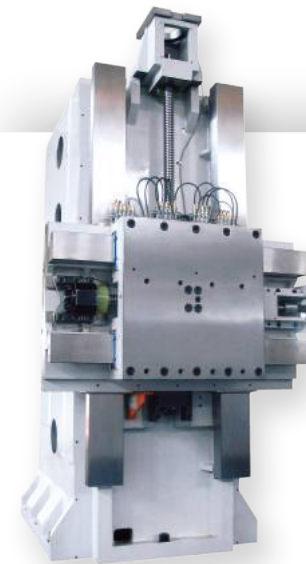

High performance rigidity column

- Wide span column with hardened box way.
- Box way design with Turcite-B coated side way and precision hand scraping.
- 20m/min rapid feed rate.
- Symmetrical axis design ensures high accuracy and long-term stability.



Spindle

- HONOR designed, assembled and tested.
- 100% spindle balancing process offers high durability.
- Symmetrical design absorbs heat variation and maintains long term stability.

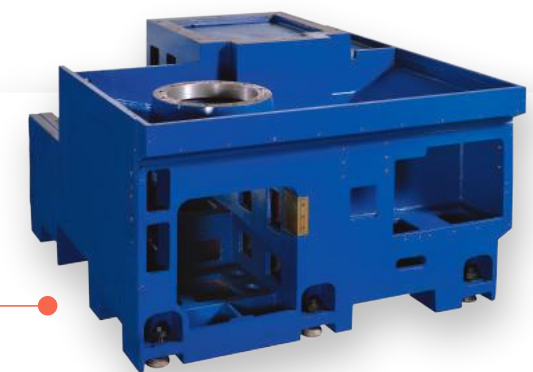

Box in box bed

- High-grade Meehanite casting with box in box structure offers high rigidity and stability for long-term heavy cutting.

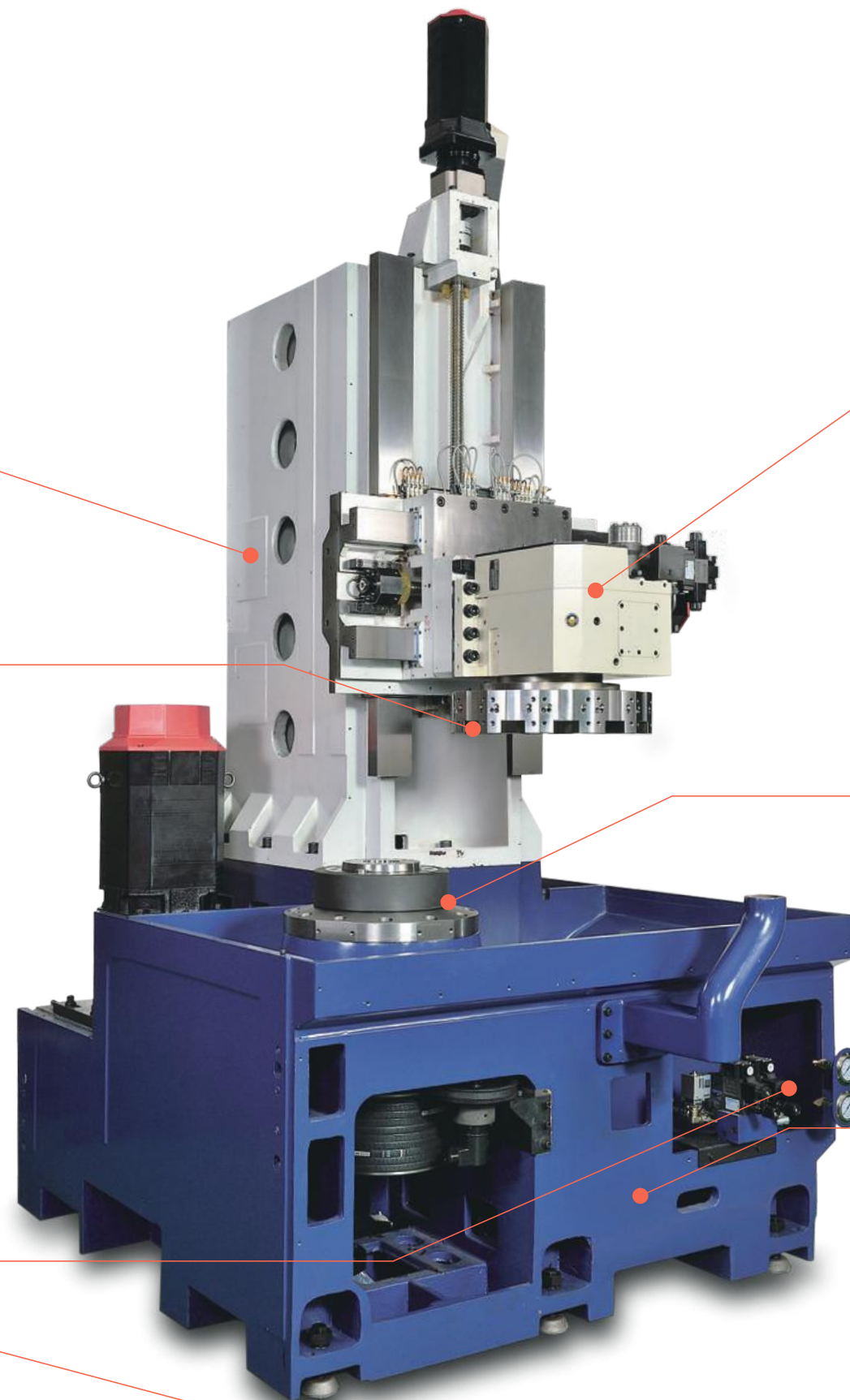

VL-46 Series

■ VL-46A / VL-46AR / VL-46G / VL-46H / VL-46M



Specification

Max. Spindle Speed : 2500 rpm
Motor (Cont. / 30 min) : 18.5 / 22 kW

- Hydraulic chuck : 305 mm (12inch)
- Number of tool position : 12
- Max. turning diameter : 560mm
- Rapid feed rate (X/Z) : 20/20 m/min
- Machine dimension : 1700 x 3100 x 2855 mm
- Machine weight : 6500 kg
- The above information is for VL-46A only.

VL-66 Series

■ VL-66A / VL-66AR / VL-66G / VL-66H / VL-66M



Specification

Max. Spindle Speed : 2000 rpm
Motor (Cont. / 30 min) : 18.5 / 22 kW

- Hydraulic chuck : 457 mm (18inch)
- Number of tool position : 12
- Max. turning diameter : 760mm
- Rapid feed rate (X/Z) : 20/20 m/min
- Machine dimension : 1950 x 3410 x 3450 mm
- Machine weight : 11500kg
- The above information is for VL-66A only.

■ Spindle Power-torque : aip40 18.5/22kW



■ Spindle Power-torque : aip40 18.5/22kW,2 steps (Option)

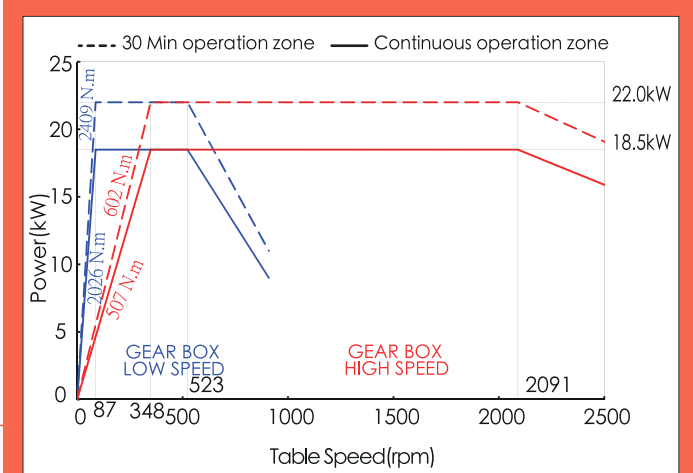

■ Spindle Power-torque : aip40 18.5/22kW

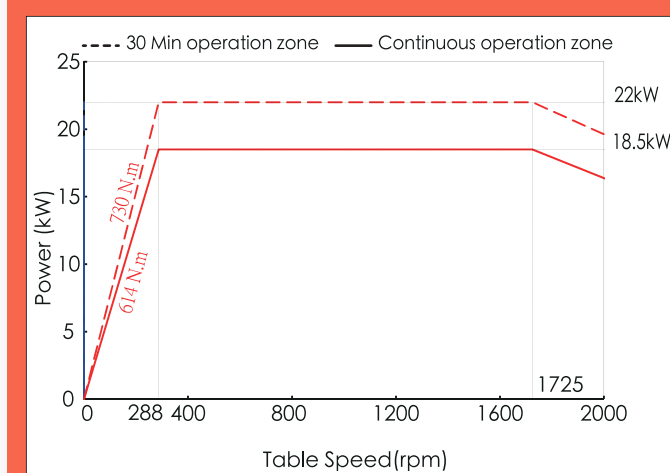

■ Spindle Power-torque : aip40 18.5/22kW,2 steps (Option)

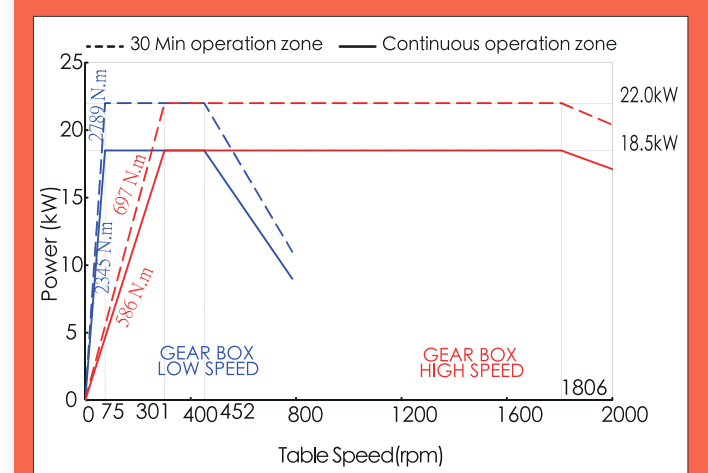

VL-86 Series

■ VL-86A / VL-86AR / VL-86G / VL-86H / VL-86M



Specification

Max. Spindle Speed : 1500 rpm
Motor (Cont. / 30 min) : 18.5 / 22 kW

- Hydraulic chuck : 533 mm (21 inch)
- Number of tool position : 12
- Max. turning diameter : 860 mm
- Rapid feed rate (X/Z) : 20/20 m/min
- Machine dimension : 2100 x 3500 x 3900 mm
- Machine weight : 14500 kg
- The above information is for VL-86A only.

VL-100 Series

■ VL-100A / VL-100M



Specification

Max. Spindle Speed : 850 rpm
Motor (Cont. / 30 min) : 37 / 45 kW

- Manual chuck : 1000mm (40inch)
- Number of tool position : 12
- Max. turning diameter : 1000 mm
- Rapid feed rate (X/Z) : 20/20 m/min
- Machine dimension : 2700 x 4000 x 4050 mm
- Machine weight : 21000kg
- The above information is for VL-100A only.

■ Spindle Power-torque : aip40 18.5/22kW,2 steps (Option)

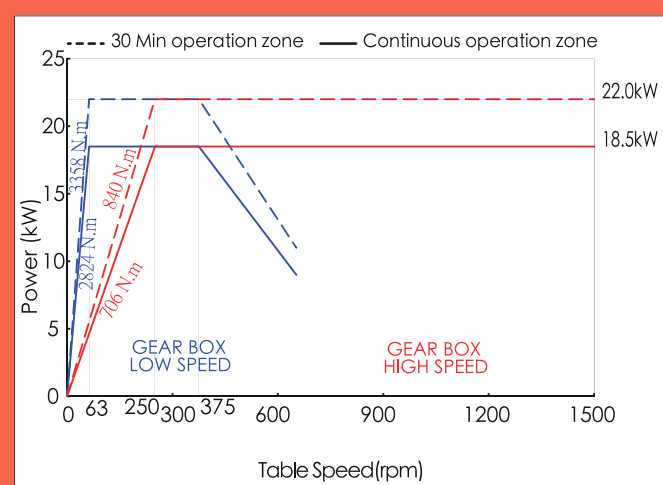

■ Spindle Power-torque : a30 30/37kW,2 steps (Option)

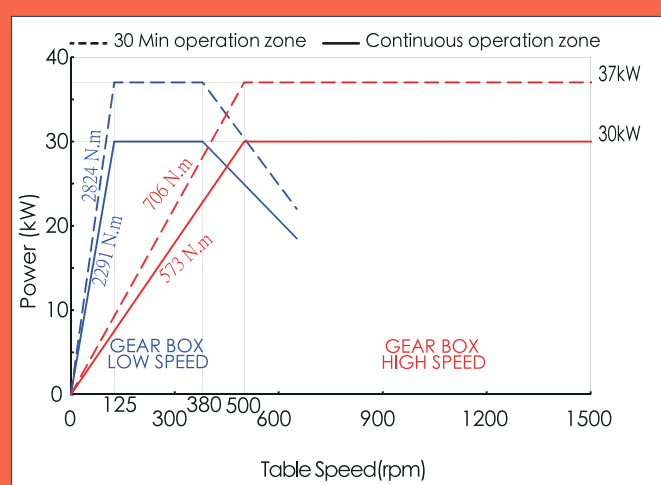

■ Spindle Power-torque : a40 37/45kW,2 steps

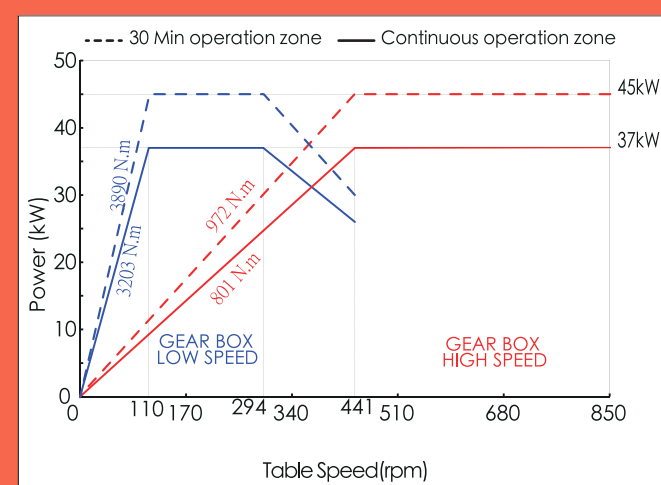

■ Spindle Power-torque : a50 45/55kW,2 steps (Option)

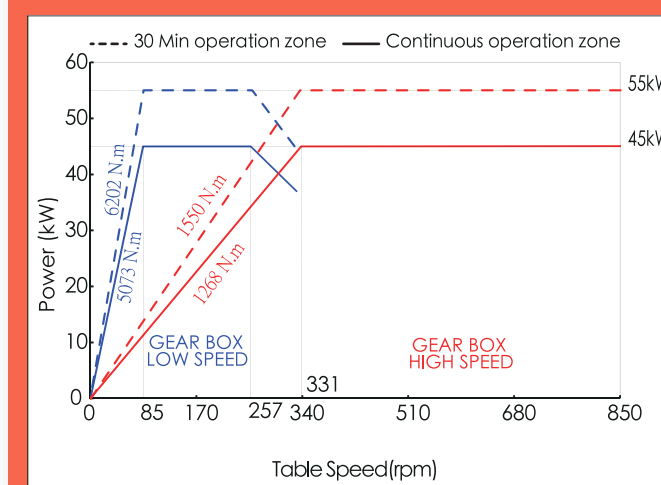

Flexible Turret Application

Horizontal type turret (H8, H12)

- Available for: VL-46A, VL-66A, VL-86A, VL-100A

Compact design and high durability, suitable for heavy cutting. High speed tool-disc rotation and smooth tool-disc clamping/unclamping to optimize the production efficiency. Particular for automotive components, like brake disc, wheel hub, knuckle...etc.

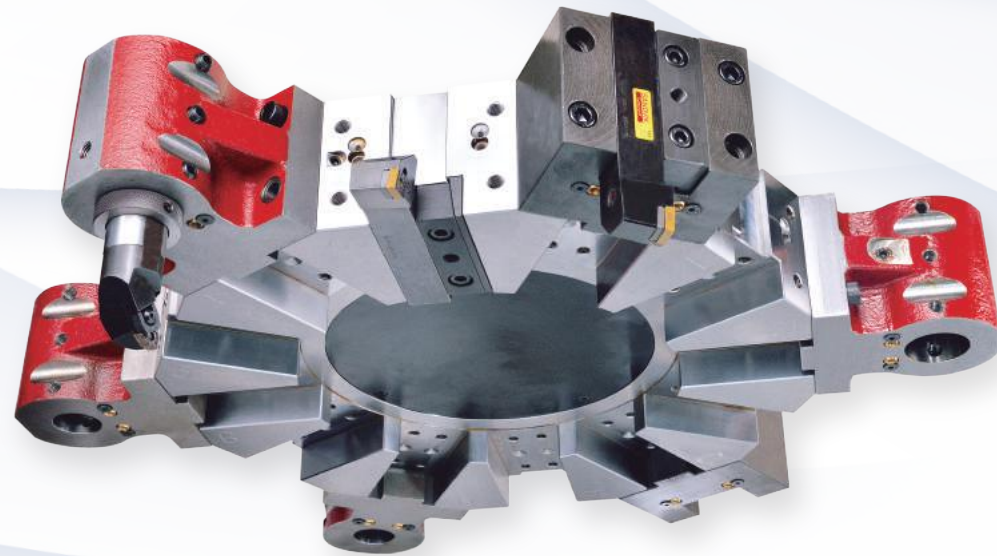

Milling type turret (BMT, VDI)

- Available for: VL-46M, VL-66M, VL-86M, VL-100M

Make drilling and tapping function in turning machine. Reduce the numbers of operations, saving the set up time and increasing the accuracy.

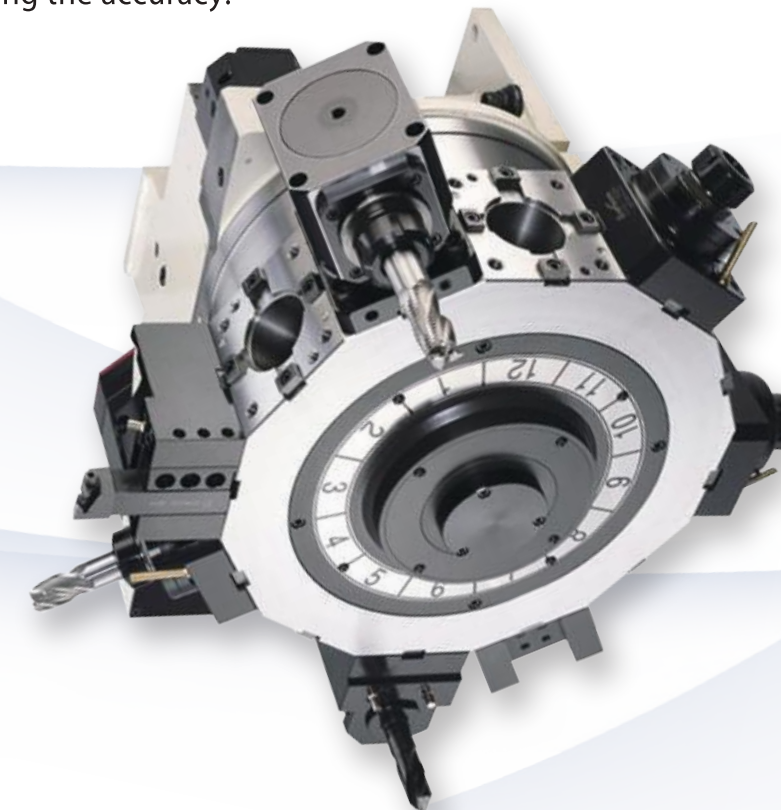

Vertical type turret (V4, V6)

- Available for: VL-46H, VL-66H, VL-86H

High rigid and high durability design, especially for brake drum, motor frame and valve.



Gang type turret (G5)

- Available for: VL-46G, VL-66G, VL-86G

Flexible tool system design, save turret indexing clamping and unclamping time to maximize production capacity. Suitable for mass production line, particular for automotive components.

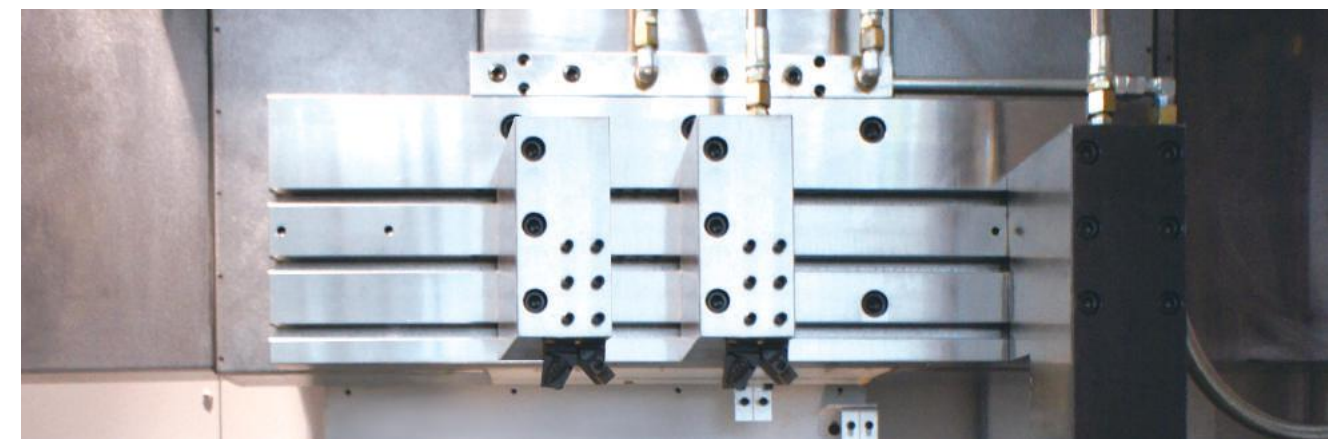

Working Area & Tool Interference

VL-46A

(unit : mm)

VL-46A(Boring Tool)

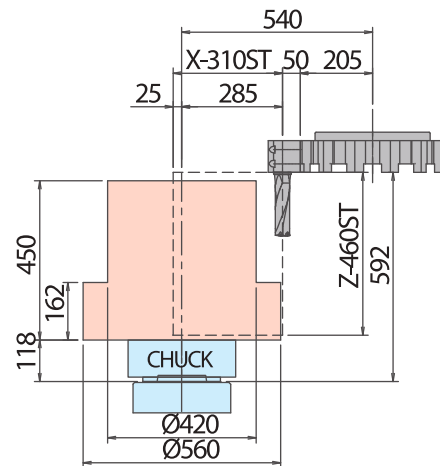

VL-46A(Face Tool)

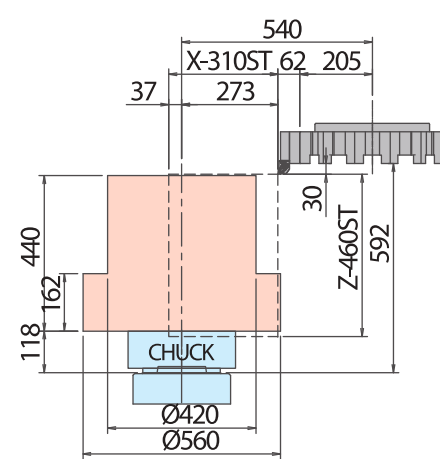

VL-46A(O.D Tool)

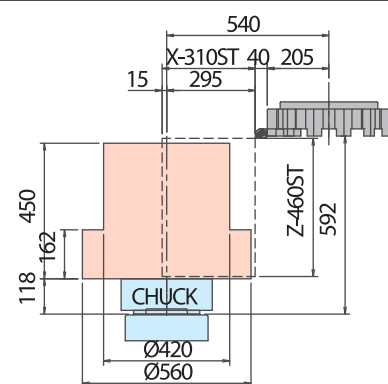

VL-46A Tool Interference

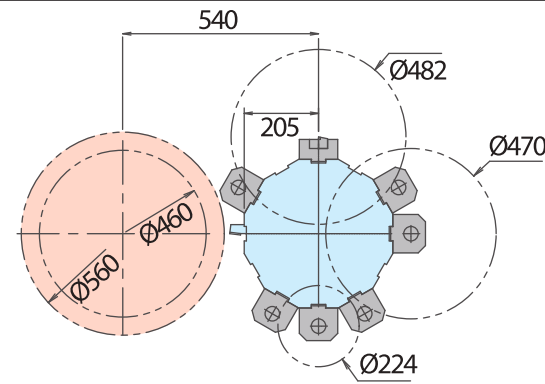

VL-66A

(unit : mm)

VL-66A(Boring Tool)

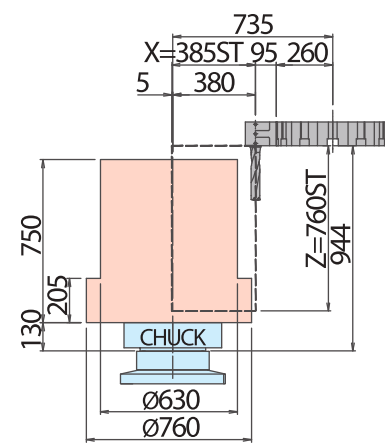

VL-66A(Face Tool)

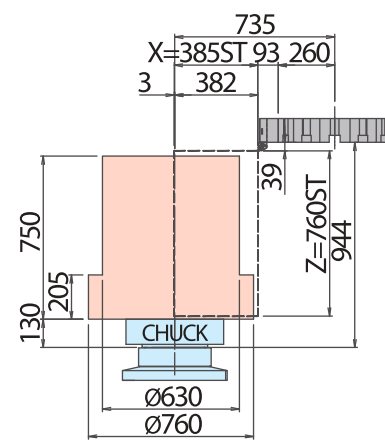

VL-66A

(unit : mm)

VL-66A(O.D Tool)

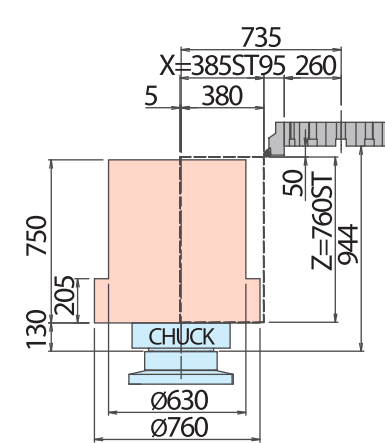

VL-66A Tool Interference

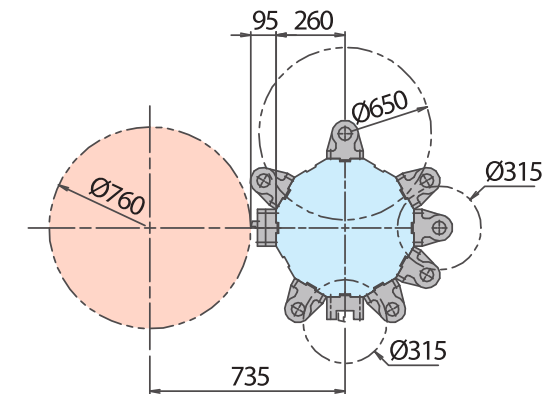

VL-86A

(unit : mm)

VL-86A(Boring Tool)

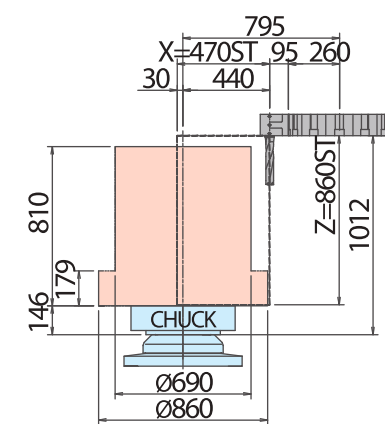

VL-86A(Face Tool)

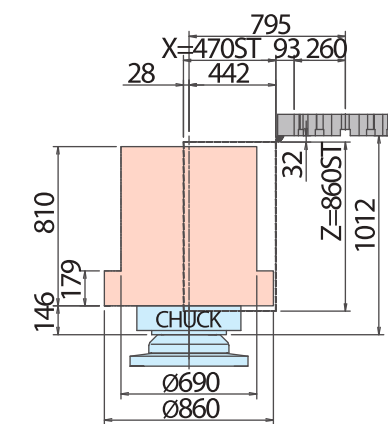

VL-86A(O.D Tool)

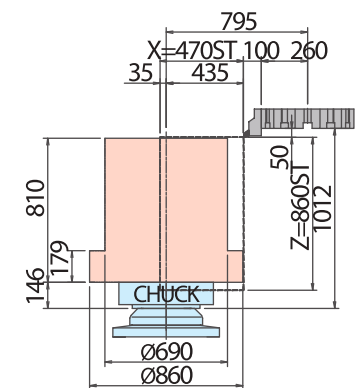

VL-86A Tool Interference

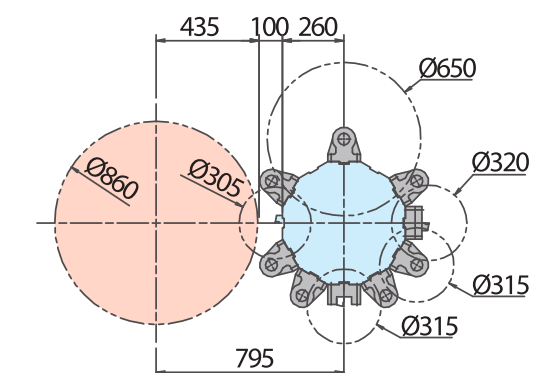

Working Area & Tool Interference

VL-100A

(unit : mm)

VL-100A(Boring Tool)

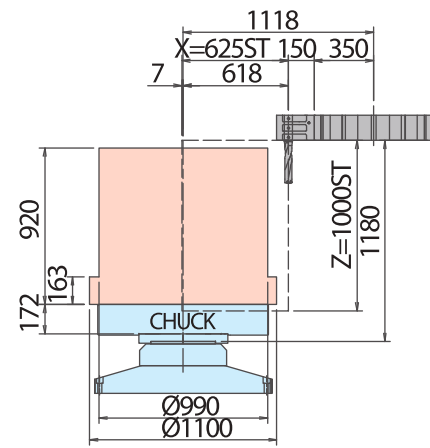

VL-100A(Face Tool)

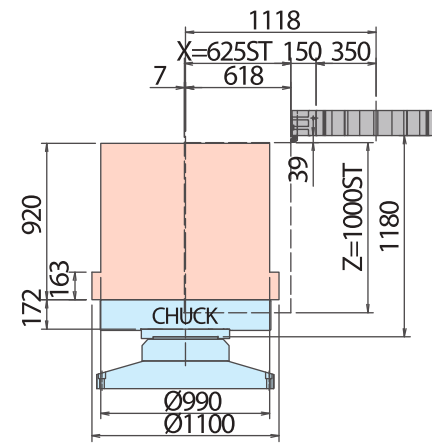

VL-100A(O.D Tool)

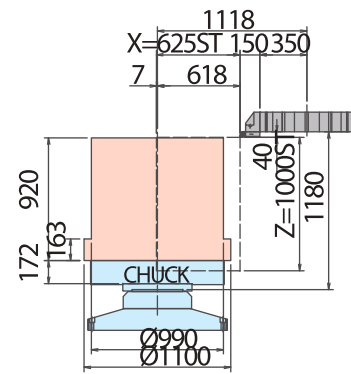

VL-100A Tool Interference

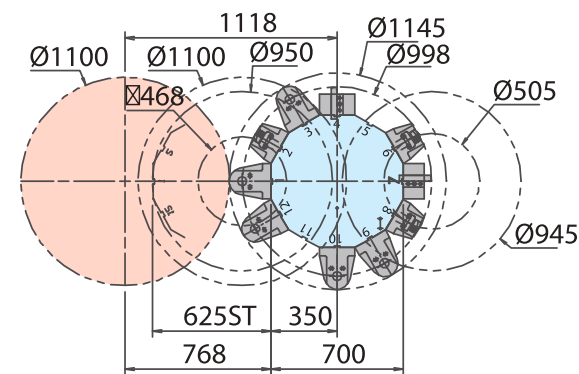

VL-46H / 66H / 86H

(unit : mm)

H Type (V4, Turret)

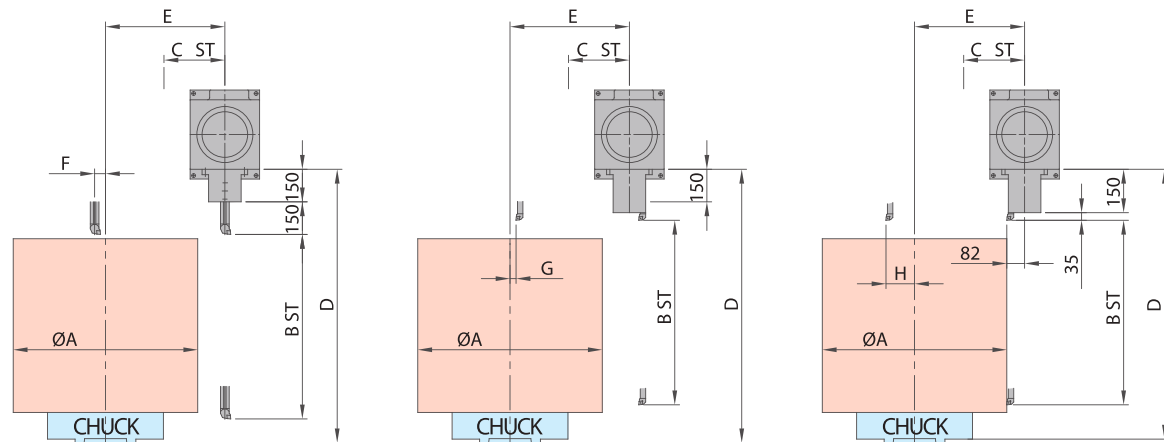

(unit : mm)

MODEL	A	B	C	D	E	F	G	H
VL-46H	500	550	320	763	310	10	13	72
VL-66H	760	700	600	990	550	50	27	112
VL-86H	860	850	600	1240	550	50	27	112

VL-46H / 66H / 86H

(unit : mm)

H Type (V6, Turret)

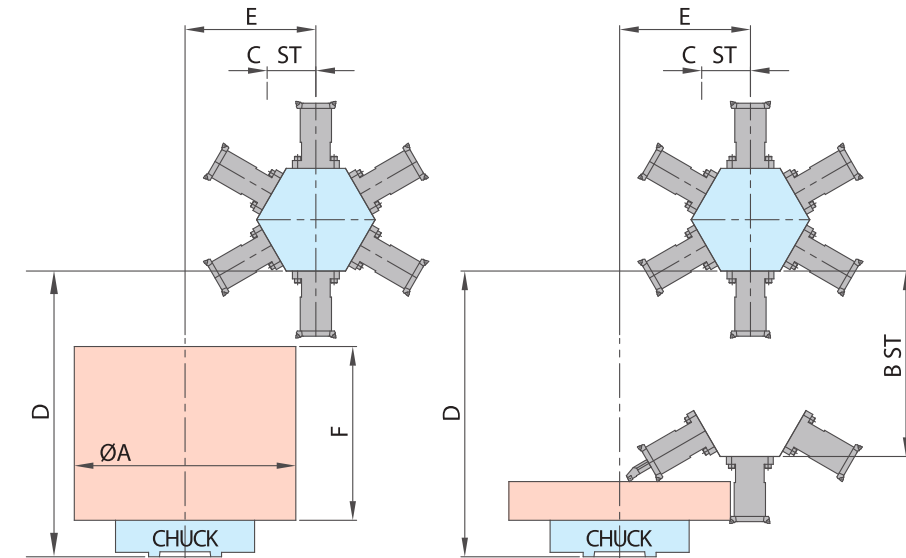

(unit : mm)

MODEL	A	B	C	D	E	F
VL-46H	500	550	320	763	310	400
VL-66H	760	700	600	990	550	620
VL-86H	860	850	600	1240	550	800

VL-46G

(unit : mm)

G Type (G5, Gang Type) / VL-46G

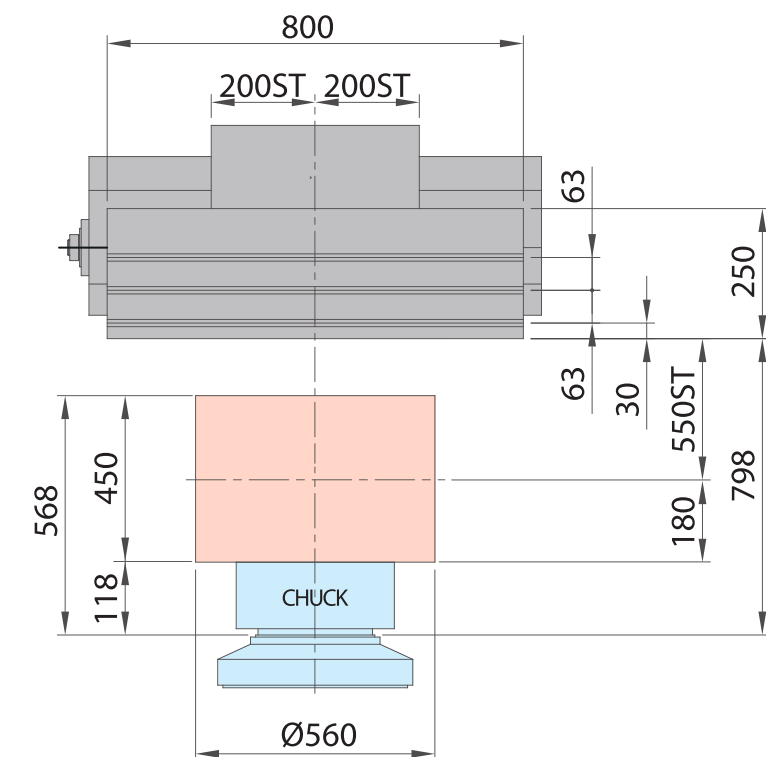

Machine Dimensions

VL-46 / VL-66 / VL-86 / VL-100 Series

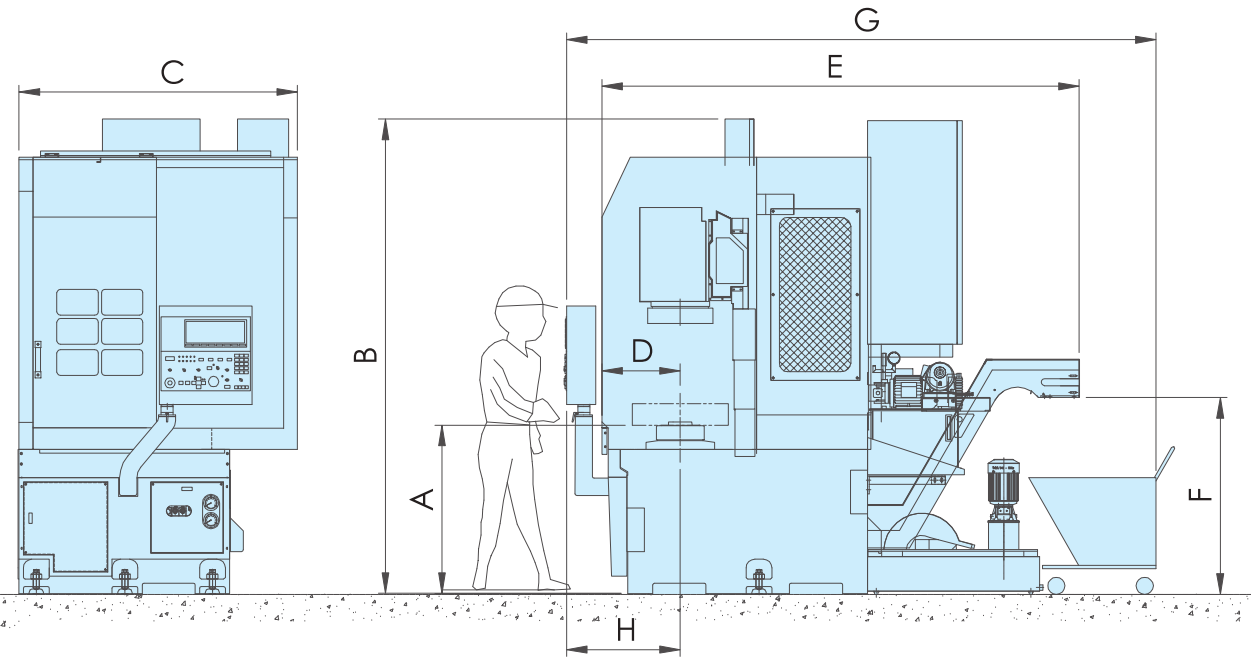

(unit:mm)

	A	B	C	D	E	F	G	H
VL-46A	990	2855	1620	457	2780	1140	3430	650
VL-66A	1080	3440	1950	505	2980	1200	3670	710
VL-86A	1200	3900	2100	655	3288	1200	3870	860
VL-100A	1250	4042	2710	755	3700	1250	4230	1030
VL-46H	980	2970	1700	453	2733	975	3432	630
VL-66H	1175	3680	2030	575	3180	1015	3885	845
VL-86H	1175	4000	2030	575	3180	1013	3885	845
VL-100H	1250	4045	3000	755	3700	1015	4230	1030
VL-46G	980	2950	2220	400	2670	975	3435	630
VL-66G	1175	3680	2070	575	3180	1015	3885	845
VL-86G	1175	4000	2070	575	3180	1015	3885	845
VL-100G	1250	4042	2710	755	3700	1250	4230	1030
VL-46M	990	2815	1620	457	2780	1140	3430	650
VL-66M	1080	3450	1950	505	2980	1200	3670	710
VL-86M	1200	3872	2100	655	3288	1200	3870	860
VL-100M	1250	4042	2710	755	3700	1250	4230	1030

Machine Dimensions

VL-46AT / VL-46MT / VL-66AT / VL-66MT / VL-86AT / VL-86MT



VL-46/66/86 Twin Series

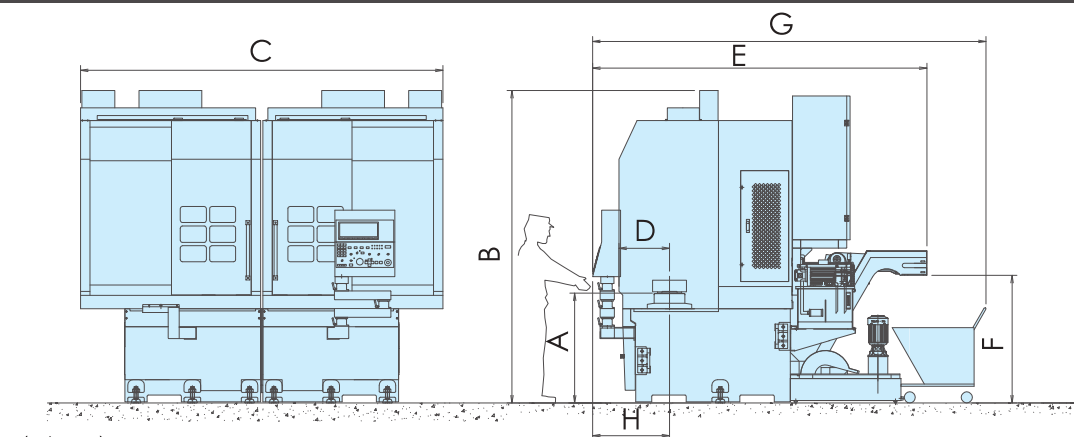

(unit:mm)

	A	B	C	D	E	F	G	H
VL-46AT/MT	990	2855	3240	457	2780	1140	3430	650
VL-66AT/MT	1080	3440	3900	505	2980	1200	3670	710
VL-86AT/MT	1200	3900	4200	655	3288	1200	3870	860

Machine Dimensions



HL-26/32 Twin Series

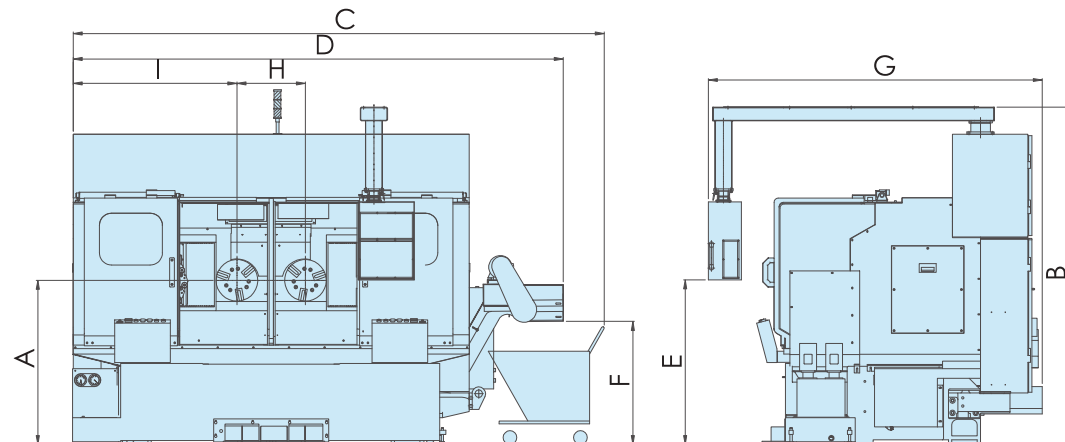

(unit: mm)

	A	B	C	D	E	F	G	H	I
HL-26AT	1150	2030	3460	3160	1126	865	1900	460	970
HL-32AT	1200	2465	3800	3180	1205	900	2440	500	1195

Option

■ Siemens controller



■ Air conditioner for electrical cabinet



■ 2-Speed gear box



■ Fully protection telescopic cover



■ Oil mist collector



■ Finger hydraulic chuck

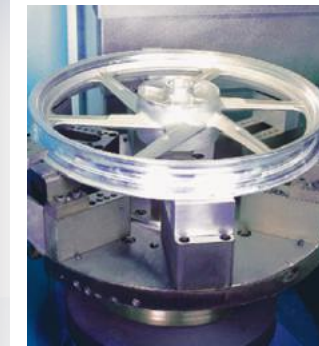

■ Second control box



■ Tool presetter



■ Double cutting



■ Oil skimmer (Disk)



■ Auto door



■ Magnetic chuck



Machine Specifications

Model / Descriptions		Unit	VL-46A/AR	VL-46AT	VL-46G	VL-46H	VL-46M	VL-46MT	VL-66A/AR	VL-66AT	VL-66H
Capacity	Max. swing diameter	mm(inch)	560 (22")		600 (23.6")	650 (25.6")	560 (22")		800 (31.4")	800 (31.4")	850 (33.4")
	Max. turning diameter	mm(inch)	560 (22")		560 (22")	560 (22")	560 (22")		760 (29.9")	760 (29.9")	760 (29.9")
	Standard turning diameter	mm(inch)	420 (16")		560 (22")	500 (19.7")	520 (20.5")		630 (24")	630 (24")	760 (29.9")
	Max. turning height	mm(inch)	450 (17.7")		450 (17.7")	400 (15.7")	380 (14.9")		750 (29.5")	750 (29.5")	620 (24.4")
Spindle	Hydraulic chuck	mm(inch)	305 (12")		305 (12")		305 (12")		457 (18")	457 (18")	457 (18")
	Range of table speed	rpm	25-2500		25-2500		25-2500		25-2000	25-2000	25-2000
	Front bearing diameter	mm	120		120		120		160	160	160
	Nose of spindle		A2-8		A2-8		A2-8		A2-11	A2-11	A2-11
Tool turret	Type of turret	-	H12	H12+H12	G5	V4/V6/V8	H12 (BMT65)	H12+H12 (BMT65)	H12	H12+H12	V4/V6/V8
	Number of tool position	ea	12	12+12	5	4/6/8	12	12+12	12	12+12	4/6/8
	Tool size	mm	□25, □32, Ø40		□25, □32, Ø40	□25, □32, Ø40	□25, Ø40		□25, □32, Ø40, Ø50	□25, □32, Ø40, Ø50	
	Tool live spindle speed		-		-	-	3000	3000	-	-	-
Feed	Rapid rate (X-Axis)	m/mim	20		20	20	20		20	20	
	Rapid rate (Z-Axis)	m/mim	20		20	20	20		20	20	
	Horizontal travel (X-Axis)	mm	310		-200+200	-10+310	310		385	385	50+550
	Vertical travel (Z-Axis)	mm	460		550	550	460		760	760	700
	Cutting feed rate	mm/rev	0.001-500		0.001-500		0.001-500		0.001-500	0.001-500	
	Feed override	%	0-150		0-150		0-150		0-150	0-150	
Control system			Fanuc 0i-T				Fanuc 0i-T		Fanuc 0i-T	Fanuc 0i-T	
Motors	Spindle motor (Cont. /30min)	kW	ap40 (18.5/22)		ap40 (18.5/22)		ap40 (18.5/22)		ap40 (18.5/22)	ap40 (18.5/22)	
	Feed motor (X/Z axis)	kW	3.0/4.0		3.0/7.0		3.0/4.0		4.0/7.0	4.0/7.0	4.0/4.0
	Live tool motor		-		-		3.7/5.5		-	-	-
Power requirement		kVA	40	75	40	45	85	40	75	40	
Machine size	Floor space (LxW)	mm(inch)	1700x3100 (66.9"x112")	3400x3100 (133.9"x112")	1700x3100 (66.9"x112")	1700x3100 (66.9"x112")	3400x3100 (133.9"x112")	1950x3410 (76.8"x134.3")	3900x3410 (153.5"x134.3")	1950x3410 (76.8"x134.3")	
	Max. height	mm(inch)	2855 (112.4")		2855 (112.4")		2855 (112.4")		3450 (135.8")		
	Net. Weight	kg(lb)	6500 (14330 lb)	13000 (28660 lb)	6500 (14330 lb)	6600 (14550 lb)	13200 (29101 lb)	11500 (25353 lb)	23000 (50706 lb)	11500 (25353 lb)	

* The specifications are subject to change without notice

Standard accessories

- Complete splash guard.
- Hydraulic 3-jaw chuck and rotary cylinder.(VL-46/66/86)
- Manual 4-jaw chuck.(VL-100)
- Hydraulic power unit.
- Soft jaws for hydraulic chuck.(VL-46/66/86)
- Automatic lubrication system.
- Heat exchanger for electrical cabinet.
- Safety glass for front door.
- Foot switch for hydraulic chuck.
- Working light.
- Warning light.(R/Y/G)
- Coolant through turret.
- Coolant system with coolant tank and bed wash down system.
- Hand tool sets with tool box.
- Leveling bolts & seat pads.
- Chip conveyor.(Hinge type)
- Chip trolley.
- Spindle orientation.
- Manual of operation & maintenance.
- Manual of electrical & hydraulic circuit diagram.
- Workpiece counter.(CNC controller)

Optional accessories

- Hydraulic chuck and rotary cylinder.(VL-100)
- Manual chuck.(VL-86 series)
- Spindle motor upgrade.
- Air conditioner for electrical cabinet.
- Auto door.(Automatic opening & closing of main door)
- Power transformer.
- Oli skimmer.(Disc type)
- Oil mist collector.
- Counter display for each inserts.
- Double cutting tools.
- Tool presetter.
- Dual speed gear box for spindle motor.
- High & low pressure chucking.
- Chuck position sensor.
- Tool holder.
- Hard jaw of chuck.
- High pressure collant through turret.
- Chip conveyor.(scraper type)
- CNC controller 31i series.
- Manual guide *i*.
- CE certificate.
- Tooling.
- Jig & fixture.
- Turnkey project.

Machine Specifications

Model / Descriptions		Unit	VL-66M	VL-66MT	VL-86A/AR	VL-86AT	VL-86H	VL-86M	VL-86MT	VL-100A	VL-100M	
Capacity	Max. swing diameter	mm(inch)	800 (31.4")	800 (31.4")	1000 (39.4")		1000 (39.4")	1000 (39.4")		1320 (52.0)		
	Max. turning diameter	mm(inch)	700 (27.5")	700 (27.5")	860 (33.9")		860 (33.9")	800 (31.5")		1100 (43.3)		
	Standard turning diameter	mm(inch)	700 (27.5")	700 (27.5")	690 (27")		860 (33.9")	800 (31.5")		990 (38")		
	Max. turning height	mm(inch)	650 (25.5")	650 (25.5")	810 (31.9")		800 (31.5")	700 (27.5")		920 (36.2")	900 (35.4")	
Spindle	Hydraulic chuck	mm(inch)	457 (18")		533 (21")		533 (21")		1000 (40")/Manual 4-jaw chuck			
	Range of table speed	rpm	25-2000		25-1500		25-1500		5-850			
	Front bearing diameter	mm	160		200		200		200			
	Nose of spindle		A2-11		A2-11 (Option A2-15)		A2-11 (Option A2-15)		ISO 702-4 No.15 (Ø380)			
Tool turret	Type of turret	-	H12 (BMT75)	H12+H12 (BMT65)	H12	H12+H12	V4/V6/V8	H12	H12+H12	H12	H12 (BMT85)	
	Number of tool position	ea	12	12+12	12	12+12	4/6/8	12	12+12	12		
	Tool size	mm	□25, Ø40, Ø50		□25, □32, Ø40, Ø50		□25, Ø40, Ø50	□25, Ø40, Ø50		□32, Ø50		
	Tool live spindle speed		3000	3000	-	-	-	3000	3000	-	3000	
Feed	Rapid rate (X-Axis)	m/mim	20		20		20	20		20		
	Rapid rate (Z-Axis)	m/mim	20		20		20	20		20		
	Horizontal travel (X-Axis)	mm	385		470		50+500	470		625		
	Vertical travel (Z-Axis)	mm	760		860		850	860		1000		
	Cutting feed rate	mm/rev	0.001-500				0.001-500				0.001-500	
	Feed override	%	0-150				0-150				0-150	
Control system			Fanuc Oi-T				Fanuc Oi-T				Fanuc Oi-T	
Motors	Spindle motor (Cont. /30min)	kW	ap40(18.5/22)				ap40(18.5/22)				α40(37/45)	
	Feed motor (X/Z axis)	kW	4.0/7.0		4.0/7.0		4.0/7.0		4.0/7.0			
	Live tool motor		7.5/11		-		-		7.5/11		-	7.5/11
Power requirement		kVA	45	85	40	75	40	45	85	80		
Machine size	Floor space (LxW)	mm(inch)	1950x3410 (76.8"x134.3")	3900x3410 (153.5"x134.3")	2100x3500 (82.7"x137.8")	4200x3500 (165.4"x137.8")	1950x3500 (76.8"x137.8")	2100x3500 (82.7"x137.8")	4200x3500 (165.4"x137.8")	2700x4000 (106.2"x157.4")		
	Max. height	mm(inch)	3450 (135.8")		3900 (153.5")		3900 (153.5")		4050 (159.4")			
	Net. Weight	kg(lb)	11600 (25574 lb)	23200 (51147 lb)	14500 (31967 lb)	29000 (63934 lb)	14600 (32188 lb)		29200 (64375 lb)	21000 (46297 lb)	21800 (48061 lb)	

Standard accessories

- Complete splash guard.
- Hydraulic 3-jaw chuck and rotary cylinder.(VL-46/66/86)
- Manual 4-jaw chuck.(VL-100)
- Hydraulic power unit.
- Soft jaws for hydraulic chuck.(VL-46/66/86)
- Automatic lubrication system.
- Heat exchanger for electrical cabinet.
- Safety glass for front door.
- Foot switch for hydraulic chuck.
- Working light.
- Warning light.(R/Y/G)
- Coolant through turret.
- Coolant system with coolant tank and bed wash down system.
- Hand tool sets with tool box.
- Leveling bolts & seat pads.
- Chip conveyor.(Hinge type)
- Chip trolley.
- Spindle orientation.
- Manual of operation & maintenance.
- Manual of electrical & hydraulic circuit diagram.
- Workpiece counter.(CNC controller)

Optional accessories

- Hydraulic chuck and rotary cylinder.(VL-100)
- Manual chuck.(VL-86 series)
- Spindle motor upgrade.
- Air conditioner for electrical cabinet.
- Auto door.(Automatic opening & closing of main door)
- Power transformer.
- Oli skimmer.(Disc type)
- Oil mist collector.
- Counter display for each inserts.
- Double cutting tools.
- Tool presetter.
- Dual speed gear box for spindle motor.
- High & low pressure chucking.
- Chuck position sensor.
- Tool holder.
- Hard jaw of chuck.
- High pressure coolant through turret.
- Chip conveyor.(scraper type)
- CNC controller 31i series.
- Manual guide *i*.
- CE certificate.
- Tooling.
- Jig & fixture.
- Turnkey project.
- Linear encoder of X/Z axis.